

June 26, 2024 08:05 PM GMT

## Artificial Intelligence

# Humanoids: Investment Implications of Embodied AI

Generative AI is driving transformational change in robotics, rapidly accelerating capital formation and adoption rate. Labor tightness and demographics further underpin the business case. TAM? A \$30 trillion global labor market. Our "Humanoid 66" stock list offers exposure to the theme.

alphawise 



Morgan Stanley does and seeks to do business with companies covered in Morgan Stanley Research. As a result, investors should be aware that the firm may have a conflict of interest that could affect the objectivity of Morgan Stanley Research. Investors should consider Morgan Stanley Research as only a single factor in making their investment decision.

**For analyst certification and other important disclosures, refer to the Disclosure Section, located at the end of this report.**

+ = Analysts employed by non-U.S. affiliates are not registered with FINRA, may not be associated persons of the member and may not be subject to FINRA restrictions on communications with a subject company, public appearances and trading securities held by a research analyst account.

# Contributors



MORGAN STANLEY &amp; CO. LLC

**Adam Jonas, CFA**

Equity Analyst  
+1 212 761-1726  
[Adam.Jonas@morganstanley.com](mailto:Adam.Jonas@morganstanley.com)



MORGAN STANLEY &amp; CO. LLC

**Sean K Corley**

Research Associate  
+1 212 761-9518  
[Sean.Corley@morganstanley.com](mailto:Sean.Corley@morganstanley.com)



MORGAN STANLEY &amp; CO. LLC

**Sarah A Wolfe**

Economist  
+1 212 761-0857  
[Sarah.Wolfe@morganstanley.com](mailto:Sarah.Wolfe@morganstanley.com)



MORGAN STANLEY ASIA LIMITED+

**Lisa Jiang**

Equity Analyst  
+852 2239-1282  
[Lisa.Jiang1@morganstanley.com](mailto:Lisa.Jiang1@morganstanley.com)



MORGAN STANLEY &amp; CO. LLC

**Brian Nowak, CFA**

Equity Analyst  
+1 212 761-3365  
[Brian.Nowak@morganstanley.com](mailto:Brian.Nowak@morganstanley.com)



MORGAN STANLEY &amp; CO. LLC

**Daniel Kutz**

Equity Analyst  
+1-212-761-0899  
[Dan.Kutz@morganstanley.com](mailto:Dan.Kutz@morganstanley.com)



MORGAN STANLEY &amp; CO. LLC

**Arunima Sinha**

Global Economist  
+1 212 761-4125  
[Arunima.Sinha@morganstanley.com](mailto:Arunima.Sinha@morganstanley.com)



MORGAN STANLEY &amp; CO. LLC

**Ariana Salvatore**

Strategist  
+1-212-761-1779  
[Ariana.Salvatore@morganstanley.com](mailto:Ariana.Salvatore@morganstanley.com)



MORGAN STANLEY ASIA LIMITED+

**Serena Chen**

Research Associate  
+852 2848-7107  
[Serena.Chen@morganstanley.com](mailto:Serena.Chen@morganstanley.com)



MORGAN STANLEY &amp; CO. LLC

**Matt Moros**

Research Associate  
+1 212 761-2163  
[Matt.Moros@morganstanley.com](mailto:Matt.Moros@morganstanley.com)



MORGAN STANLEY ASIA LIMITED+

**Stanley Wang**

Research Associate  
+852 2848-7382  
[Stanley.Wang@morganstanley.com](mailto:Stanley.Wang@morganstanley.com)



MORGAN STANLEY &amp; CO. LLC

**Daniela M Haigian**

Research Associate  
+1 212 761-6071  
[Daniela.Haigian@morganstanley.com](mailto:Daniela.Haigian@morganstanley.com)



MORGAN STANLEY &amp; CO. INTERNATIONAL PLC+

**Edward Stanley**

Equity Strategist  
+44 20 7425-0840  
[Edward.Stanley@morganstanley.com](mailto:Edward.Stanley@morganstanley.com)



MORGAN STANLEY &amp; CO. LLC

**Seth B Carpenter**

Chief Global Economist  
+1 212 761-0370  
[Seth.Carpenter@morganstanley.com](mailto:Seth.Carpenter@morganstanley.com)



MORGAN STANLEY &amp; CO. LLC

**Ravi Shanker**

Equity Analyst  
+1 212 761-6350  
[Ravi.Shanker@morganstanley.com](mailto:Ravi.Shanker@morganstanley.com)



MORGAN STANLEY &amp; CO. LLC

**Devin McDermott**

Equity Analyst and Commodities Strategist  
+1 212 761-1125  
[Devin.McDermott@morganstanley.com](mailto:Devin.McDermott@morganstanley.com)



MORGAN STANLEY ASIA LIMITED+

**Shelley Wang, CFA**

Equity Analyst  
+852 3963-0047  
[Shelley.Wang@morganstanley.com](mailto:Shelley.Wang@morganstanley.com)



MORGAN STANLEY &amp; CO. LLC

**Kristine T Liwag**

Equity Analyst  
+1 212 761-2980  
[Kristine.Liwag@morganstanley.com](mailto:Kristine.Liwag@morganstanley.com)



MORGAN STANLEY &amp; CO. LLC

**Bas R Jaspers**

Equity Strategist  
+1-212-761-0268  
[Bas.Jaspers@morganstanley.com](mailto:Bas.Jaspers@morganstanley.com)



MORGAN STANLEY &amp; CO. LLC

**Nancy Hipp**

Research Associate  
+1 212 761-1311  
[Nancy.Hipp@morganstanley.com](mailto:Nancy.Hipp@morganstanley.com)



MORGAN STANLEY &amp; CO. LLC

**Sebastian Almodovar**

Research Associate  
+1 212 761-1841  
[Sebastian.Cuchi-Almodovar@morganstanley.com](mailto:Sebastian.Cuchi-Almodovar@morganstanley.com)



MORGAN STANLEY &amp; CO. LLC

**Justin M Lang**

Research Associate  
+1 212 761-6251  
[Justin.Lang@morganstanley.com](mailto:Justin.Lang@morganstanley.com)



MORGAN STANLEY &amp; CO. LLC

**William J Tackett**

Research Associate  
+1 212 761-6028  
[William.Tackett@morganstanley.com](mailto:William.Tackett@morganstanley.com)



MORGAN STANLEY &amp; CO. LLC

**Stephen C Byrd**

Equity Strategist  
+1 212 761-3865  
[Stephen.Byrd@morganstanley.com](mailto:Stephen.Byrd@morganstanley.com)



MORGAN STANLEY ASIA LIMITED+

**Sheng Zhong**

Equity Analyst  
+852 2239-7821  
[Sheng.Zhong@morganstanley.com](mailto:Sheng.Zhong@morganstanley.com)



MORGAN STANLEY &amp; CO. LLC

**Brian Harbour, CFA**

Equity Analyst  
+1 617 856-8090  
[Brian.Harbour@morganstanley.com](mailto:Brian.Harbour@morganstanley.com)



MORGAN STANLEY &amp; CO. LLC

**Joe Laetsch, CFA**

Equity Analyst  
+1 212 761-8804  
[Joe.Laetsch@morganstanley.com](mailto:Joe.Laetsch@morganstanley.com)



MORGAN STANLEY &amp; CO. LLC

**Joseph Moore**

Equity Analyst  
+1 212 761-7516  
[Joseph.Moore@morganstanley.com](mailto:Joseph.Moore@morganstanley.com)



MORGAN STANLEY &amp; CO. LLC

**Matt Bombassei**

Research Associate  
+1-212-761-9811  
[Matt.Bombassei@morganstanley.com](mailto:Matt.Bombassei@morganstanley.com)



MORGAN STANLEY &amp; CO. INTERNATIONAL PLC+

**Matias Ovrum**

Equity Strategist  
+44 20 7425-9902  
[Matias.Ovrum@morganstanley.com](mailto:Matias.Ovrum@morganstanley.com)



MORGAN STANLEY &amp; CO. LLC

**Julian Herrera**

Research Associate  
+1 212 761-1784  
[Julian.Herrera@morganstanley.com](mailto:Julian.Herrera@morganstanley.com)



MORGAN STANLEY ASIA LIMITED+

**Chelsea Wang**

Equity Analyst  
+852 2239-1118  
[Jinlin.Wang@morganstanley.com](mailto:Jinlin.Wang@morganstanley.com)

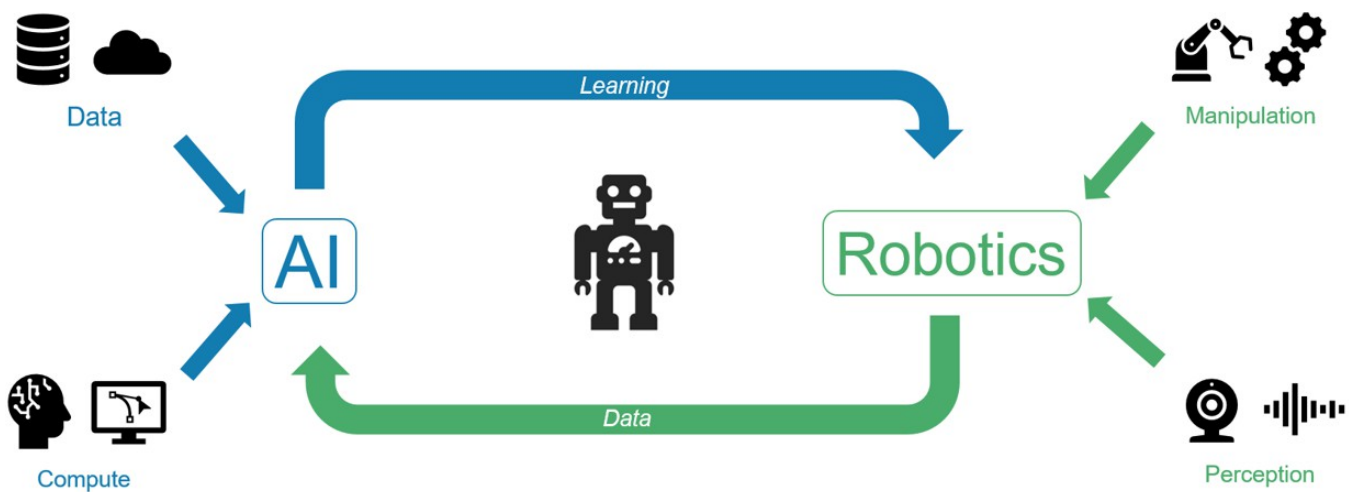
# Contents

5	The Humanoid Story in Numbers
6	A Foreword by Ed Stanley, Head of European Thematic Research
7	Executive Summary
18	Why Humanoids?
20	The Humanoid 66: Global Stock 'Expressions'
24	Scenario Framework: Labor Shortage Meets AI
30	Labor Market and the Humanoid TAM
52	Anatomy of a Humanoid: Mapping the Supply Chain
65	Sector Adjacencies — Industries Ripe for Disruption
88	Humanoid Robotics and Capital Formation
94	Humanoid Competitive Landscape
112	Three Humanoid Primers
121	Economic and Labor Considerations
133	Appendix I — Humanoid Robots: The World of Physical AI
138	Appendix II — AlphaWise Humanoid Transcript Analysis
143	Appendix III — The Case for Tesla as an AI Enabler
147	Appendix IV — Domestic Robotics: Moonshots
149	Appendix V — Payback Analysis Excel Backup

# Humanoids: Investment Implications of Embodied AI

- Advancements in AI are transforming the robotics industry. We believe adoption of "embodied AI" may be far more rapid than autonomous vehicles.
- Labor shortage and demographic trends increase the commercial relevance and paths of adoption (and economic pay-back period) across a broad range of industries.
- We built a proprietary TAM model examining the labor dynamics and humanoid optionality across >830 job classifications. Global labor market is \$30 trillion.
- We include a comprehensive competitive analysis and a proprietary "Bot BOM" from our robotics teams in Asia to help investors think about hardware cost curves.
- This report introduces the "Humanoid 66" stock list, Morgan Stanley's grouping of stocks most exposed to the humanoid robotics theme.

**Exhibit 1:** Humanoids = Robotics x AI<sup>2</sup>



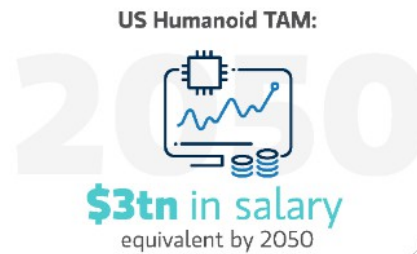
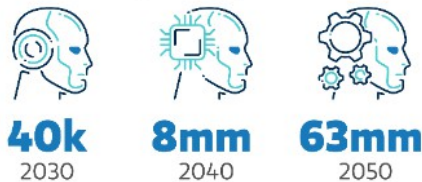
Source: Morgan Stanley Research



# The Humanoid Story in Numbers



**US Humanoid Population**  
Morgan Stanley forecast:



We estimate an initial **Optimus BOM** cost of **\$50-\$60k/unit**, with significant potential for cost reduction at scale



Taking these and other industry data points into account, we see a humanoid payback period of just **6 - 12 months** for most major use-cases



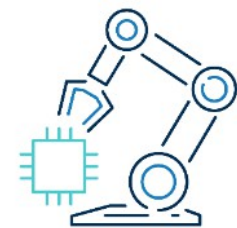
Tesla CEO **Elon Musk** believes **Optimus** could sell for **\$20k or less** ("less than half the price of a car")

Humanoid startup **Figure AI** was recently valued at **\$2.6bn**

**Investors involved** in private humanoid startups include Amazon, NVIDIA, OpenAI, ARK Invest, Microsoft, Softbank, Tiger Global, among many others



**Public companies** exploring humanoids use-cases include Amazon, BMW, Dongfeng Motor, GXO Logistics, Hyundai, Magna, Mercedes-Benz, NIO



Source: BLS, Company Data, Crunchbase, Morgan Stanley Research estimates

# A Foreword by Ed Stanley, Head of European Thematic Research

Investors consistently ask us where the puck is going. The puck is already on a trajectory toward embodied AI. It is *the* power-law trade of the next decade, and underappreciated by public market investors.

We first wrote on this topic in our [Moonshots](#) report in 2022 — a report in which the bottom line stated that “since 2000, 1% of companies generated 40% of shareholder returns.” Revisiting the topic just two years later, we are surprised to have already been proven too conservative on two counts:

1. This report argues that humanoids will arrive far sooner than even the most ardent bulls we interviewed for that Moonshots work could have expected. This has in part been precipitated by an explosion of competition beyond long-standing pioneers like Engineered Arts into the mainstream by companies like Tesla and Xiaomi, among others.
2. At the time of writing Moonshots, the “brains” of these robots were evolving orders of magnitude faster than their bodies. While this is still the case, improvements in actuators, harmonic drives and prosthetics in a short period of time mean humanoids are at an inflection point in their usefulness, cost, progress through the “uncanny valley,” and thus investor interest.

As the [Pessimists Archive](#) documents back to 1850, such an investment theme will not be without its detractors. In the case of humanoids, the initial concern will be that of job losses. So it was with wage-arbitrage-induced robotics installations in Asia for manufacturing workers in the early 2000s and again post-GPT for services workers. We see a more optimistic future than the one painted by technology de-accelerationists — one where robots continue to complement and further enhance human labour and productivity and one in which mundane and hazardous work can be outsourced.

But perhaps more pressing still is the starker reality that we will **need** humanoids. In our view, they sit squarely at the intersection of two of Morgan Stanley’s key themes: [Tech Diffusion](#) and [Longevity](#). By 2030, the United Nations forecasts a US population with 25 people aged over 70 for every 100 people aged 24-69 to look after them — a “dependency ratio” of 25%. In Japan, it will be twice as acute, with 50 people over 70 years old per 100 people to care for them. Western Europe’s dependency ratio is projected to be 35% by the end of the decade; China’s, only 20% now, will double by 2050.

Social care is arguably the world’s largest TAM by the end of the century, but one that suffers from restrictive funding creating a lack of incentivisation to recruit or re-skill workers. Humanoids will face many challenges. And while they may not be the best solution, they are an increasingly necessary solution for a world facing immense longevity challenges.

# Executive Summary

*"Dad, tiger cubs learn by watching their mothers hunt!"* my 9-year-old son declared at a Jonas family dinner. *"They practice by pouncing on patches of grass and then with small prey like little deer."*

For years, machine learning was limited to self-reinforcing software algorithms. The advancement of large language models (LLMs) and GenAI have made a great leap into the field of robotics, accelerating how physical machines learn — through natural language, imitation, simulation.


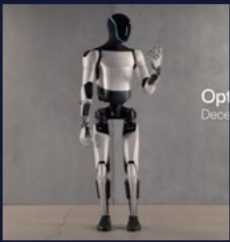
**GenAI is transforming how robots "learn"** by giving them a chance to observe and imitate behaviors in both the physical and virtual world, connected through natural language and iterated in the data-center. Similar to how large language models (LLM) help drive ever greater capability of ChatGPT, multi-modal models (MMM) are driving innovation in robotics. AI algorithms can significantly shorten the R&D cycle by automating repetitive asks, enhancing data analysis and predictive capabilities, enabling virtual simulation, and optimizing design and testing processes. As an "AI-adjacent" field, humanoid hardware development can now directly benefit from the increased capital formation and R&D investment into the robotics theme.

**AI leaps into the physical/atomic world.** AI is all around us. AI listens to you. AI sees your face and body. AI knows where you are right now.

AI can read. AI can write. AI can talk. AI can make a picture of cats wearing little cowboy hats playing Canasta. But other than running loads of algos and activating a few switches, *AI rarely ever actually moves.* In nature, "**motility**" is an organism's ability to move independently under its own energy. According to [fossil records](#), the earliest evidence of motility on earth traces back to bacterial flagella (spindle-like extensions used for locomotion) in the Precambrian era. *The lines between mobile device and robot are beginning to blur.*

**Why humanoids?** Many investors reading this report will ask the question "*why do we need robots shaped like humans?*" There are indeed strong arguments for robotics to take many highly specialized forms (robot arms, snake-shaped robots, robot dogs, robotic dust and as many form factors as you can imagine). However, many robot and AI experts say the strongest argument for robots in a human form factor is that in a world already created for humans, the environment is already "brownfielded" for humanoids. Nvidia CEO Jensen Huang recently stated "*The easiest robot to adapt into the world are humanoid robots because we built the world for us. We also have the most amount of data to train these robots than other types of robots because we have the same physique.*" Additionally, think of the great variety of tasks that humans are able to perform with our bare hands or using tools and the multitude of machines designed for human hands and fingers.

**Exhibit 2:** Pros and Cons of Humanoids vs. Specialized Robotics

Specialized Robotics	Vs.	Humanoids
		
<ul style="list-style-type: none"> <li><span style="color: green;">+</span> Technology readily available; Less mechanically and computationally intense</li> <li><span style="color: green;">+</span> Highly effective at simple, repetitive tasks that require limited dexterity</li> <li><span style="color: red;">-</span> Ineffective at tasks that require advanced dexterity and/or intelligence</li> <li><span style="color: red;">-</span> May require significant modifications to the workplace to accommodate</li> </ul>		<ul style="list-style-type: none"> <li><span style="color: green;">+</span> Capable of accomplishing complex tasks that require advanced dexterity and/or intelligence</li> <li><span style="color: green;">+</span> Limited need to modify existing workplace or methods; Interchangeable with humans.</li> <li><span style="color: red;">-</span> Technology still in development; requires highly-advanced AI and mechanical engineering</li> <li><span style="color: red;">-</span> May require significant training / trial &amp; error</li> </ul>

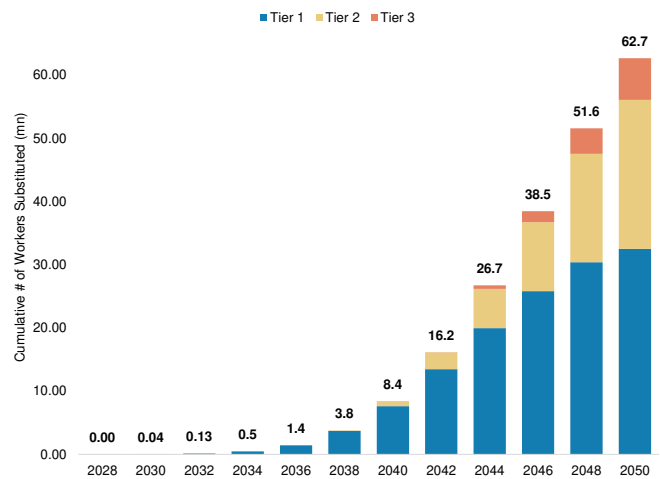
Source: Tesla, Wikipedia, Morgan Stanley Research

**Framing the TAM.** As of November 2023, the [US labor force](#) stands at around 162 million people. At an average salary of [\\$59,428](#), the US labor market is worth just shy of \$10 trillion annually. According to [Statista](#), there are approximately 3.4 billion people employed worldwide. Assuming a [\\$9k/worker](#) annual salary implies approximately a \$30 trillion global labor market ([roughly 30% of global GDP](#)). Given the thousands of individual jobs performed by humans, the TAM exercise required a far more detailed analysis across job stratification to understand the path of humanoid substitution gated by economic paybacks, supporting supply chain/infrastructure, and other factors. As such, we built a proprietary Morgan Stanley Humanoid TAM model to address a more realistically available subset within the "theoretical \$30 trillion universe" over time. In our US TAM model, we forecast a humanoid population (cumulative/installed base) of 8 million units by 2040 (\$357 billion wage impact) and 63 million units by 2050 (\$3 trillion wage impact). While our analysis does not currently consider a humanoid installed base greater than the existing human labor pool, there are scenarios where the economic benefits of the technology could make this a reality.

At his most recent AGM, Tesla CEO Elon Musk expressed his belief that humanoids will eventually outnumber humans by two-to-one or more: *"I think the ratio of humanoid robots to humans will probably be at least two-to-one, something like that. One-to-one for sure. So, which means like somewhere on the order of 10 billion humanoid robots. Maybe, maybe, maybe 20 billion or 30 billion."*

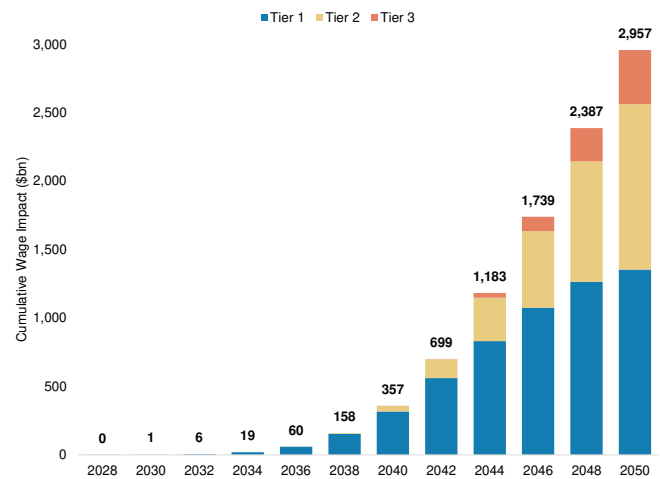
For more details on the TAM and corresponding methodology, see the ["Labor Market and the Humanoid TAM"](#) section.

**Exhibit 3:** Cumulative Number of US Jobs with Humanoid Optionality, 2028-50 (mn)



Source: Bureau of Labor Statistics, Morgan Stanley Research

**Exhibit 4:** Cumulative US Wage Impact, 2028-50 (\$bn)

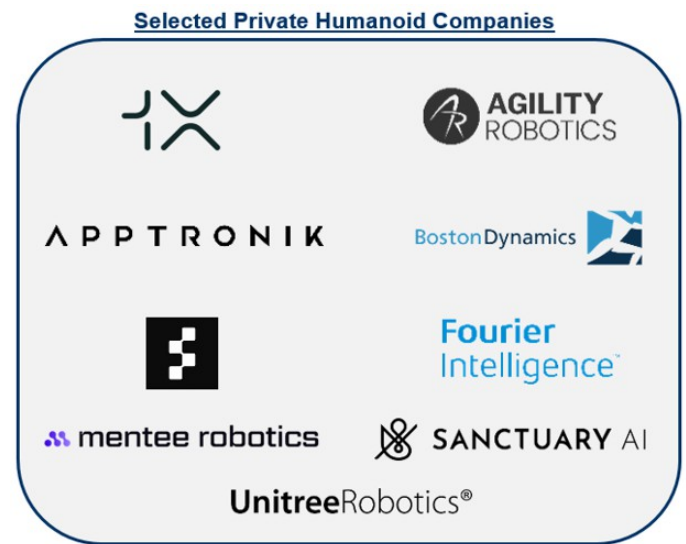


Source: Bureau of Labor Statistics, Morgan Stanley Research

**One billion humanoid robots by the 2040s?** Tesla CEO Elon Musk has been increasingly focused on Optimus (Palo Alto engineering center) in recent months, per his comments. Tesla first unveiled its humanoid robot, Optimus, on September 30, 2022. The bipedal robot included 28 actuators in two categories: 1) rotary actuators, consisting of harmonic reducers, ball bearings and sensors, for rotating motions such as shoulders and elbows; 2) linear actuators, comprising planetary rollers, ball bearings and sensors for linear motions like human muscles. Twelve actuators for two hands. Many more details have been kept internally at the company. In January of this year, Elon Musk said he expected to see **over 1 billion humanoid robots** in operation by the 2040s. At Tesla's June 13th 2024 annual shareholder meeting, Mr. Musk stated he expects to have at least 1,000 Optimus robots working at Tesla next year, and that *"things are gonna scale up very rapidly from there."* In the same meeting, Mr. Musk expressed his confidence that humanoid robots will eventually outnumber human beings and "probably be 20 billion or more" (no timeline shared).

**A dynamic, fast changing competitive landscape.** Beyond Tesla, dozens of startups and established firms have engaged in humanoid robotics development on the back of the rapid growth of GenAI in 2022/2023. We note even before **NVIDIA's keynote speech** in March 2024 — which left little to the imagination about the company's intentions for physical AI — robotics were a recurring AI theme, including at the Morgan Stanley TMT Conference last March. After a number of false starts, an array of venture investors and companies across are betting on the promise of embodied AI. Humanoid startups **Figure AI** and **Agility Robotics** have been valued at \$2.6 billion and \$1.2 billion, respectively, in private funding rounds this year, with the broader theme attracting major investors including OpenAI, Softbank, Tiger Global, Amazon, NVIDIA, and Microsoft among others. Additionally, major public companies, across industries ranging from automotive to consumer electronics, are actively involved in humanoid development, while others are actively partnered with humanoid startups to explore potential future use cases.

**Exhibit 5:** Selection of Private Humanoid Companies/Startups



Note: This list is only a selection of private efforts. There is an increasing number of humanoid and humanoid adjacent firms being formed, which may not be included in this exhibit. However, we include here as investors cannot invest directly in Boston Dynamics.

Source: Company Websites, Morgan Stanley Research

**Exhibit 6:** Selection of Public Companies Involved in Humanoid Development or Exploring Implementing Humanoids in the Workplace.



Note: Not all-inclusive.

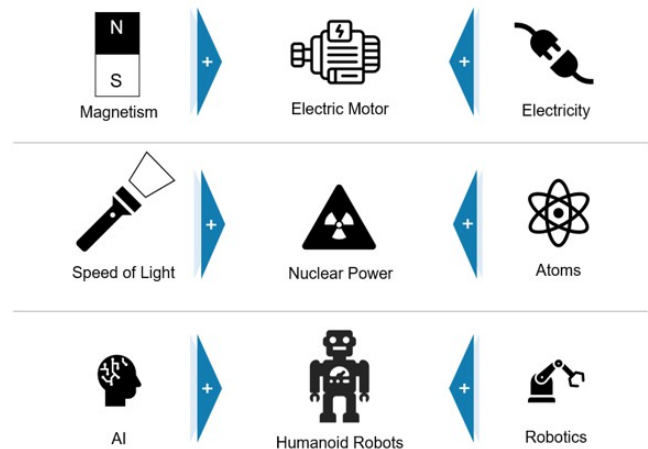
Source: Company Websites, Morgan Stanley Research



**Robotics having a ChatGPT "moment."** According to Vincent Vanhoucke (Senior Director for Robotics at Google DeepMind), experts in the robotics community refer to two years ago as "the good old days" as he explains how LLMs and genAI have very abruptly flung the field of robotics from an isolated "robot island" firmly onto the "AI flywheel." The science of LLM (large language models) and generative AI had long been seen as completely separate from the world of robotics (actuation). These worlds are colliding and the impacts are profound. We've been here before. In 1821, Michael Faraday ran an electric current through a wire suspended over a magnet in a glass... observing the rotation of the wire. This marked not only the discovery of how electrical energy can create mechanical movement (the first electric motor) but it also connected two areas of science that until then seemed unrelated — electricity and magnetism. Albert Einstein found connections between the properties of physical matter and light that were previously never conceived ( $E=mc^2$ ). Might we be on the verge of unlocking the relationship between gen AI and robotics?

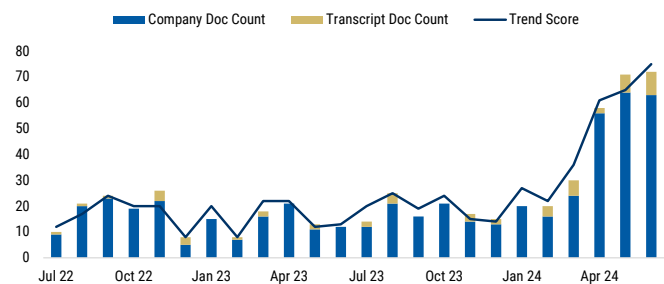
**Cybernetic collective robotic learning.** Imagine for a moment a humanoid robot standing in front of a kitchen island on which an onion sits on a small plate next to a paring knife. Now imagine a large warehouse with 1,000 humanoid robots each standing next to a kitchen island with the onion on a plate next to a knife. As each trial and error accumulates among the group, the entire population learns at the collective rate of the best robot at any point in time. The aggregated learning of the cybernetic collective "spools up" to achieve an accelerated frontier of group learning. When the physical practice is completed with a "winning" robot having peeled its onion better than the other 999, best practices can then be shared and further improved through hundreds of millions of trials among their digital twins in a simulated 'Omniverse.'

**Exhibit 7:** Seemingly Unrelated Areas of Science Can Combine With Profound Effect



Source: Morgan Stanley Research

**Exhibit 8:** "Humanoid" Mentions in Public Company Transcripts (conferences and earnings calls)



Source: Alphasense, Morgan Stanley Research

**Exhibit 9:** With NVIDIA Project GR00T, humanoid robots train in a simulated version of reality called "Omniverse." The below image shows digital twins of Apptроник, Agility, and Unitree robots in training.



Source: NVIDIA

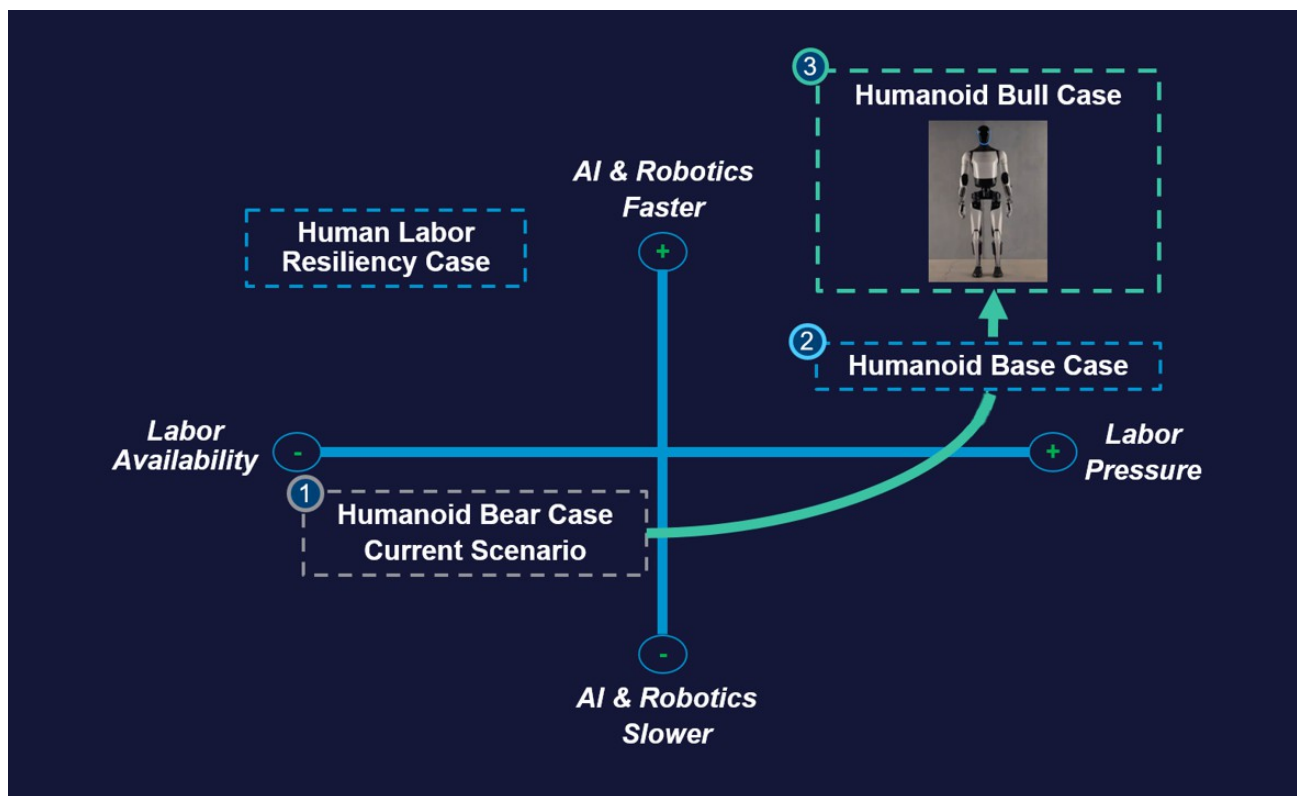
**Have you seen or interacted with a robot today?** Some of you may have. Most of you reading this in the summer of 2024 likely have not. This rather nostalgic period of human technological history is quickly passing. The ongoing LLM/Gen AI revolution is in the early days of crossing over into robotics. LLM and robotics were long seen as vastly different areas of science. But there may be far more overlap in how the advancement of LLM accelerates the training and learning of the robot — whether it is a "car shaped" robot or a human shaped one. The AI brain is searching for its robot "body."

**Humanoid vs. autonomous cars.** Autonomous vehicles (AVs) are robots. Rather simple robots, in the form factor of a car. By simple, we mean there are only three primary actuation outputs of a robotaxi: (1) steering wheel, (2) accelerator pedal angle and (3) brake pedal. However, the operating domain is extremely complex — public roads riddled with unpredictable elements. We believe that the humanoid time to commercialization will materialize faster than AVs given the

variability of the AV operating environment (real world) and corresponding safety implications (human passengers, pedestrians) vs. the humanoid form factor, which can learn in a geo-fenced domain (warehouse/factory closed work cells). *Even though humanoids have more physical outputs, the difficult operating domain, safety concerns, and regulatory scrutiny that autonomous vehicles face pushes their adoption curve out to the right in our view.*

**Key drivers of humanoid adoption:** The story of humanoid robotics involves an understanding of three primary domains: AI, robots and people. At various stages, advancements in AI (multi-modal models, neural-net training, compute) may progress faster than the physical science of robotics (i.e., optics, actuation, battery, manufacturing) which may march along its own path of potentially non-linear improvement. All the while, a number of drivers of labor factors across industries and regions will significantly determine economic payback periods, adoption rates and social acceptance.

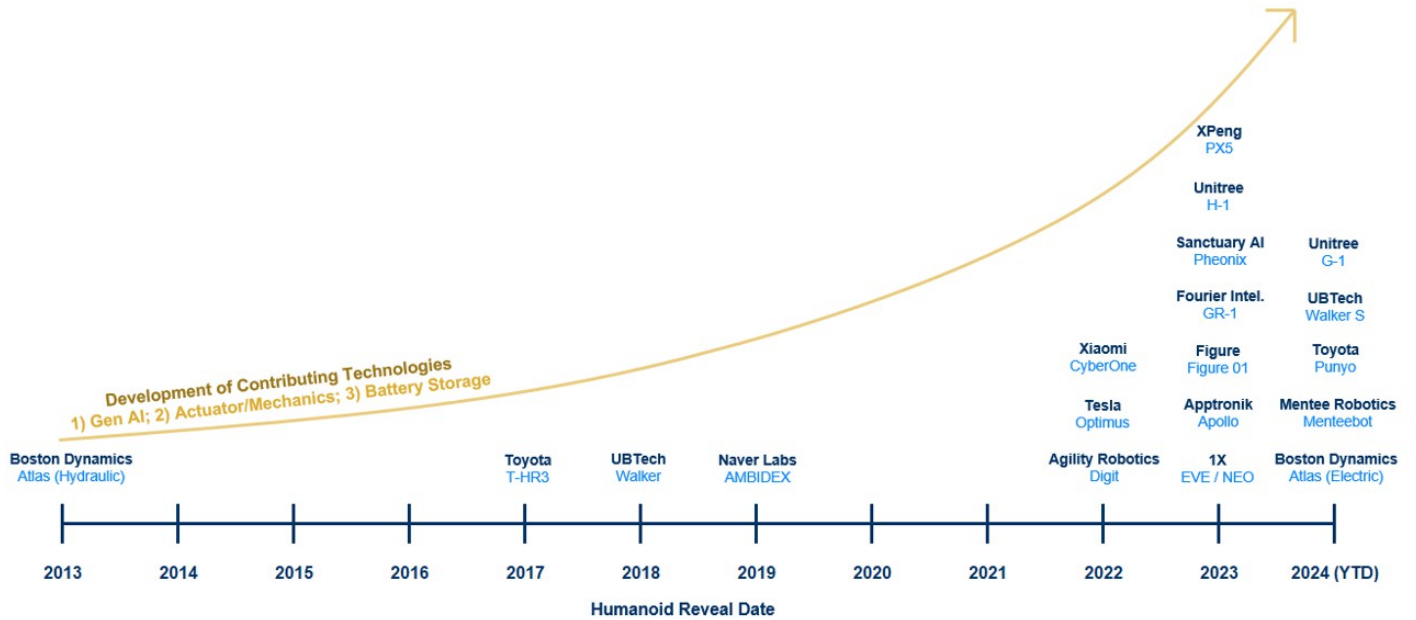
**Exhibit 10:** Labor Availability vs. AI & Robotics Acceleration



Source: Morgan Stanley Research

While advanced humanoid development remains in its early stages, we believe the path of progress over the past few years in the adjacent areas of 1) gen AI, 2) actuators & mechanics, and 3) battery storage are proving to be significant contributors to humanoid development. Further advancements in these 3 areas will be key to achieving humanoid commercialization.

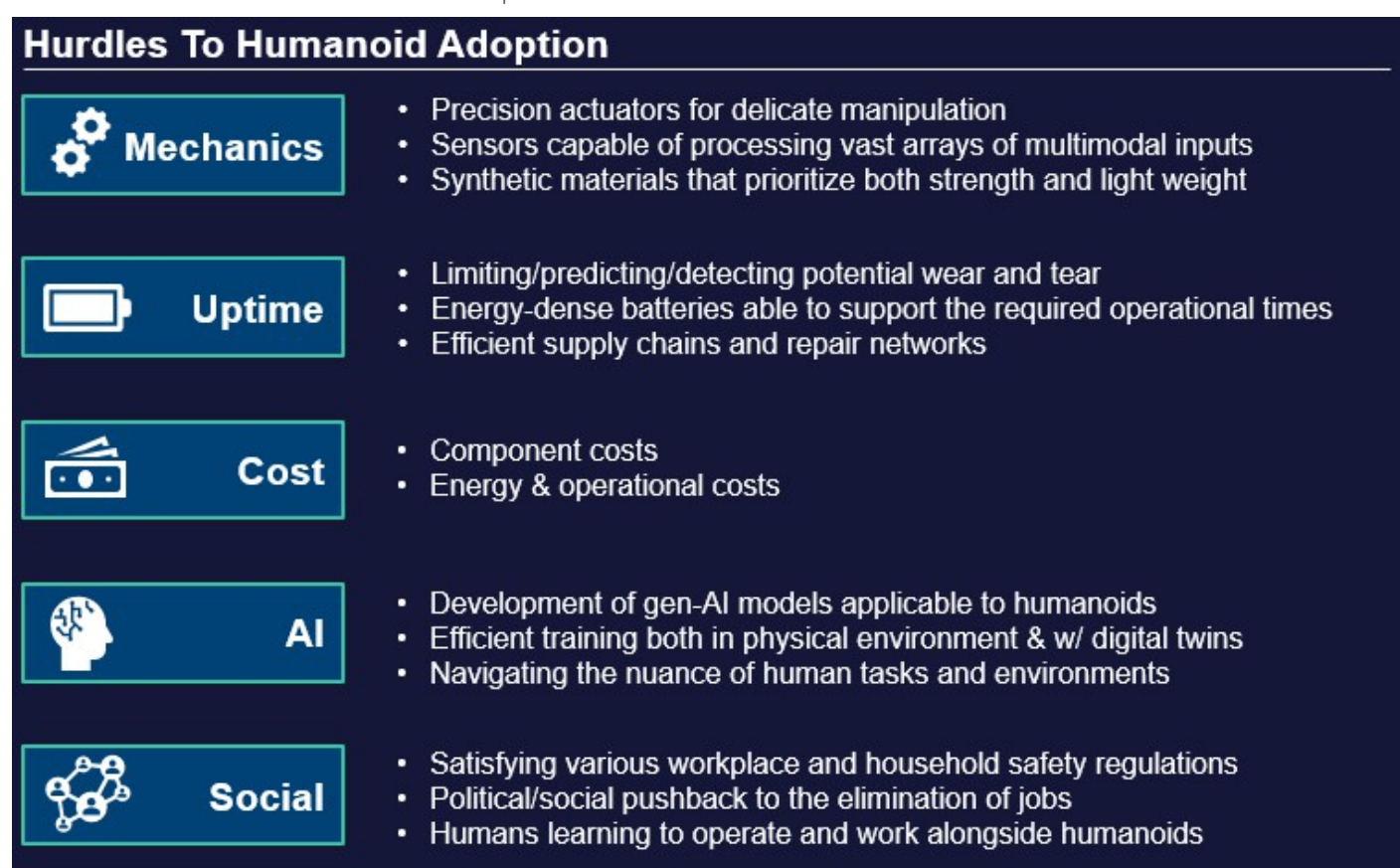
**Exhibit 11:** As contributing technologies have advanced over the past decade, intelligent humanoid development has continually increased in relevance.



Source: Company Data, Morgan Stanley Research

**A number of gating factors must also be considered.** Widespread commercialization of humanoid robots at scale must overcome a host of technological challenges as well as a wide range of societal/policy/safety impediments along the way. On the tech side, creating humanoids able to navigate the nuances/complexities of human environments will likely require continued advancements in gen-AI as well as efforts to tailor these advanced models specifically for humanoids. Additionally, further refinement of precision actuators, sensors, and battery capacity will be critical to improving the scope of tasks that can be executed by humanoids. Despite decades of modern robotics development, the sudden and rapid rise of GenAI models may create scenarios where the "mental" capabilities of humanoids surpass the physical capabilities, opening the door to a range of potential hardware bottlenecks that will need to be addressed as humanoids become exponentially "smarter." The social/policy/safety considerations as they relate to AVs helps us understand the range of potential hurdles for humanoids. However, we believe the ability to train humanoids using digital twins or in closed-off, geo-fenced work cells, as opposed to public streets, gives humanoids a relative advantage in approaching potential safety regulations.

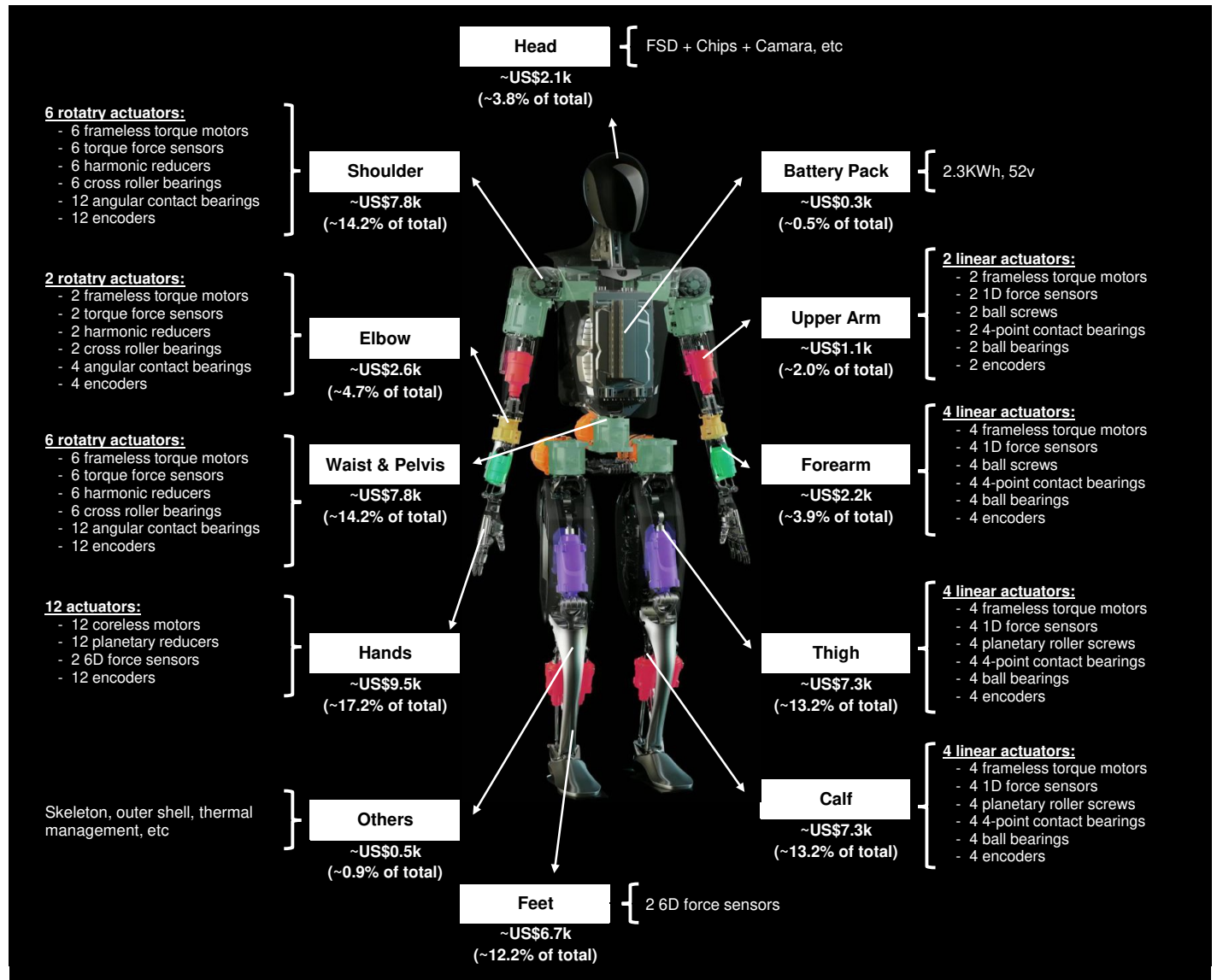
**Exhibit 12:** Potential Hurdles to Humanoid Adoption



Source: Morgan Stanley Research

**Leveraging the Morgan Stanley Asia Industrials cortex, we assess the humanoid bill-of-materials (BOM) and map the key enablers within the humanoid supply chain.** From China Industrials (Sheng Zhong) to Japan Industrials (Lisa Jiang) and China Auto Suppliers (Shelley Wang), we dive into the inner-workings of a humanoid, breaking down component costs and the potential for future cost reduction. Per our estimates, building humanoid robots could range from \$10k to \$300k depending upon configuration and downstream application. For example, per primary component supplier price quotes and proprietary analyses, we estimate Tesla Optimus Gen2's current BoM is \$50-60k per unit (ex-software). However, with the benefit of scale, the introduction of AI algorithms to significantly shorten the R&D cycle, and the utilization of cost effective components from China, we see opportunities for significant cost reduction to achieve CEO Elon Musk's targeted Optimus selling price of ~\$20k. For more detail, see the "Anatomy of a Humanoid: Mapping the Supply Chain" section.

**Exhibit 13:** We estimate current total ex-software BoM for Tesla Optimus at \$50-60k per unit.



Source: Tesla, Morgan Stanley Research.



**What can investors do today to prepare for the humanoid robot revolution?** Through cross sector collaboration we have presented Morgan Stanley's proprietary humanoid "portfolio" of stocks across dozens of sectors and global regions to identify both "enablers" and "beneficiaries" of humanoid robots. We present the **Humanoid 66** not so much as an exhaustive list of names but a starting point where contributing Morgan Stanley analysts offer a number of paths for "expression" on the theme. For details on methodology, categories, and regions, see [The Humanoid 66: Global Stock 'Expressions'](#)

**We use three approaches to identify sectors that are best positioned for humanoid adoption:**

**1. Top-down analysis.** We considered sectors that involve the greatest amount of boring, repetitive, or dangerous physical labor, and those that are most unionized or have the highest unit labor costs are best positioned.

**2. Bottom-up analysis.** We parsed through the Bureau of Labor Statistics' US employment list and evaluated the extent to which physical labor is required for each occupation (831 total US occupations). We considered the sectors that have the highest degree of physically intensive jobs as best positioned for adoption. Extrapolating the analysis, we created a TAM model that sizes the potential impact of humanoids on the US labor market from the perspective of wages and number of jobs.

**3. Proprietary humanoid sector survey.** We asked each Morgan Stanley Research US sector analyst to assess the extent to which their coverage is exposed to humanoid disruption based on seven survey questions. We ranked each sector according to those that involve physically intensive or boring/repetitive/dangerous jobs, are facing labor shortages, or are already focused on automating physical work.

**Exhibit 14:** Bottom-up Analysis: Summary of US Industry Tiering Methodology

		Ranked		
Tier	Industry	US Total Employment (mn)	# Adoptable (mn)	% Adoptable
1	Construction and Extraction	6.2	4.4	70%
1	Production	8.8	6.0	68%
1	Farming, Fishing, and Forestry	0.4	0.3	67%
1	Building and Grounds Cleaning and Maintenance	4.4	3.0	67%
1	Installation, Maintenance, and Repair	6.0	4.0	66%
1	Healthcare Support	7.1	4.6	66%
1	Food Preparation and Serving Related	13.2	8.4	64%
1	Personal Care and Service	3.0	1.9	61%
2	Protective Service	3.5	2.0	58%
2	Transportation and Material Moving	13.8	7.6	55%
2	Sales and Related	13.4	5.8	43%
2	Healthcare Practitioners and Technical	9.3	3.8	41%
2	Life, Physical, and Social Science	1.4	0.5	39%
2	Architecture and Engineering	2.5	0.8	33%
3	Educational Instruction and Libraries	8.7	2.9	33%
3	Office and Administrative Support	18.5	4.4	24%
3	Management	10.5	1.3	12%
3	Arts, Design, Entertainment, Sports, and Media	2.1	0.2	11%
3	Business and Financial Operations	10.1	0.6	6%
3	Legal	1.2	0.0	2%
3	Community and Social Service	2.4	0.0	1%
N/A	Computer and Mathematical	5.2	0.0	0%
<b>Total</b>		<b>151.9</b>	<b>62.7</b>	<b>41%</b>

**Adoption begins 2028**

**Adoption begins 2036**

**Adoption begins 2040**

Source: Bureau of Labor Statistics, Morgan Stanley Research

Exhibit 15: Humanoid 66: Enablers and Beneficiaries



Source: Morgan Stanley Research

**Introduction to our report: *Humanoids: Investment Implications of Embodied AI***

**Understanding the humanoid theme requires a multi-sector approach and a long term time horizon.** Having said that, we believe investors should prepare for an extraordinary number of developments and milestones over the next 6 to 12 months. This report is the product of many months of work across the Morgan Stanley Global Research sector stack, including our Economics, Public Policy, and Thematic teams. In addition, we have conducted numerous interviews with subject matter experts ranging from venture capital to the robotics and AI industry.

**We aim to bring our readers from "zero to one" on the topic of humanoids, or further our client thinking on a thematic domain that we believe will have increasing relevance on a wide range of covered industries, ultimately materializing into capital formation in the public market.** We took a similar approach with our work on autonomous vehicles in 2013 and with the space industry in 2017. *While the path to commercialization at scale may take decades to fully play out, we believe it is not too soon to begin understanding the implications today.*

While there is clearly some momentum and innovation in the humanoid robot theme, we note that much of the development is both early stage and outside of the public domain. As such, we have made a number of assumptions across a wide range of inputs impacting our TAM forecasts and adoption curves. **Beyond the specificity of the output, we present our humanoid analysis and TAM model in the spirit of "open source" to help our clients think about the key drivers, further testing their thought process through sensitivity analysis.**

*We are not aware of any other [Humanoid TAM model](#) in the market with comparable detail to help investors run scenarios and test sensitivities through 2050. We would be happy to share our model with Morgan Stanley clients (to request a copy, please contact your Morgan Stanley sales representative).*


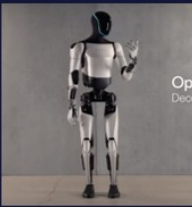
# Why Humanoids?

## Why Humanoids vs. Specialized Robots?

**Humanoid is just a robot form factor.** Humanoid robots may not represent the majority of robots globally in the future as different form factors specialized for certain tasks emerge (i.e., claws, automated forklifts, dogs, etc.). However, the scope of this report is focused solely on humanoid robots, which we believe will be the most consequential form factor near term for the following key reasons:

- **The world is designed for humans by humans, already brown-fielded for human robot form factor**
- **Humanoids are hard, but not as hard as redesigning the world for a different robot form factor**
- **Lots of humans to observe and imitate, which is important for data collection and training**
- **Improvements in universal manipulation (robot hands) expand the use cases and improve payback periods of humanoids**
- **Humanoid robots ensure interchangeability with humans for the same job — enables a controlled "phase-in" adoption, avoiding an all or nothing approach**
- **Ensures humans remain relevant or don't forget physical work and tasks in the event the humanoids are unavailable**
- **Humanoids can work together with dedicated tools including specialized robots/co-bots to improve efficiency**
- **Expressive humanoids may improve social acceptance across many categories (healthcare, education, co-working with humans)**

**Exhibit 16:** Pros and Cons of Humanoids vs. Specialized Robotics from an Operator Perspective

Specialized Robotics	Vs.	Humanoids
		
<ul style="list-style-type: none"> <li><span style="color: green;">+</span> Technology readily available; Less mechanically and computationally intense</li> <li><span style="color: green;">+</span> Highly effective at simple, repetitive tasks that require limited dexterity</li> <li><span style="color: red;">-</span> Ineffective at tasks that require advanced dexterity and/or intelligence</li> <li><span style="color: red;">-</span> May require significant modifications to the workplace to accommodate</li> </ul>		<ul style="list-style-type: none"> <li><span style="color: green;">+</span> Capable of accomplishing complex tasks that require advanced dexterity and/or intelligence</li> <li><span style="color: green;">+</span> Limited need to modify existing workplace or methods; Interchangeable with humans.</li> <li><span style="color: red;">-</span> Technology still in development; requires highly-advanced AI and mechanical engineering</li> <li><span style="color: red;">-</span> May require significant training / trial &amp; error</li> </ul>

Source: Tesla, Wikipedia, Morgan Stanley Research

**During a CNBC Interview on Wednesday, March 20, Nvidia CEO Jensen Huang said he thinks the humanoid form factor in robotics could potentially transform manufacturing.**

Jim Cramer: "Why do robots look like people?"

Jensen Huang: "Robots look like people because ... a couple of reasons. The first reason, and the most important reason, is that we built the world for ourselves, and so the work stations of a factory, the manufacturing line of a factory, was really created for people. And that's the most important reason.

"The second most important reason is that we have to teach a robot how to be a productive robot, and you need data for that. We're in a world where, in order to write software for a computer, we use data, or training examples, and the computer learns from the examples. Well, we have the most examples of humans moving around as just about any other form of data."

## Humanoids vs. Robotaxis: Time to Commercialization

**Excitement around autonomous cars has been waning for some time, highlighted most recently by Apple's decision to cancel its [autonomous car project](#).** There are many thousands of people with expertise in computer vision, robotics, electric motors, software-hardware integration and other related disciplines that have been focused on autonomous car development for the past decade. If AV development continues to get "pushed to the right" we would expect top talent to be "re-deployed" into the next-closest disciplines. Controlling those negative headline-making incidents in autonomous cars is proving to be more difficult than many expected. *Cherry picking from the thousands of the most repetitive, boring and dangerous human tasks may prove to be far easier with humanoid bots on a factory line, warehouse or kitchen than with autonomous cars on public roads.*

**Our message to investors:** We wrote in a March report, [On Bots](#), to prepare for the theme of humanoid robotics to accelerate in the months and years ahead for a number of factors. We recently discussed our thoughts in a December note where we discussed "mobile AI" as akin to a [Cambrian Explosion](#) that may profoundly impact our way of life.

**We believe that the humanoid adoption curve will be faster than AVs given the variability, unpredictability, and complexity of the AV operating environment (real world) and corresponding safety implications (human passengers, pedestrians) vs. the humanoid form factor, which operates in a geo-fenced domain (warehouse/factory workcells). Even though humanoids have more physical outputs, at ~50+ points of movement on the humanoid body across different joints and limbs vs. a vehicle's ~3 outputs (wheel, gas, brake), the difficult operating environment, safety concerns, and regulatory scrutiny that autonomous vehicles face pushes their adoption curve out to the right.**

“

Robots look like people because ... the most important reason, is that we built the world for ourselves, and so the workstations of a factory, the manufacturing line of a factory, was really created for people.

”

Jensen Huang



# The Humanoid 66: Global Stock 'Expressions'

**The Humanoid 66 is Morgan Stanley's proprietary list of stocks that best expresses the humanoids theme.** The list includes 66 public companies hand-picked by Morgan Stanley's global research team that we believe could play a role in developing humanoids, or that could benefit from the emergence of humanoid labor, or both. We categorize the Humanoid 66 stocks into the below groups:

- **Enabler:** Companies that develop humanoid robots or humanoid robot inputs (brain and body)
- **Beneficiary:** Companies that could benefit from humanoid labor
- **Enabler & Beneficiary:** Companies that both develop humanoids/humanoid inputs *and* could benefit from humanoid labor

To select **enablers** for the Humanoid 66, we identified companies that are developing:

- **Humanoid robots**
- **Parts**, especially those that are responsible for fine motor skills and movement, such as precision actuators
- **Batteries**, essential to powering humanoids
- **Semiconductors**, including those for centralized high-performance computing (HPC), MCUs/MPUs, sensors, and power

For **beneficiaries**, we:

- Selected companies from the **top four sectors** that stand to benefit most from the emergence of humanoid labor according to our [proprietary sector survey](#). These sectors are **Transportation, Autos, Oil & Gas**, and **Restaurants**.
- Selected companies from two sectors that are not stand-alone sectors under Morgan Stanley Research, but according to our TAM analysis involve a high percentage of physical labor relative to other job types. These sectors are **Construction** and **E-Commerce**.

Our Humanoid 66 stock list includes global companies from the US, Japan, Asia ex-Japan, and Europe. 3 companies are both enablers and beneficiaries, 33 are enablers, and 30 are beneficiaries:

## Exhibit 17: The Humanoid 66

## Humanoid 66

#	Company	Ticker	Price	Sector	Analyst	Region	Classification
<b>Enabler &amp; Beneficiary</b>							
1	Tesla, Inc.	TSLA	183	Autos & Shared Mobility	Adam Jonas	United States	Enabler & Beneficiary
2	Toyota Motor	7203	3,296	Japan Autos & Shared Mobility	Shinji Kakiuchi	Japan	Enabler & Beneficiary
3	XPeng Inc.	09868	31	China Autos & Shared Mobility	Tim Hsiao	Asia ex-Japan	Enabler & Beneficiary
<b>Enabler</b>							
4	Mobileye Global Inc.	MBLY	27	Autos & Shared Mobility	Adam Jonas	United States	Enabler
5	Dassault Systemes	DAST	35	Technology - Software & Services	Adam Wood	Europe	Enabler
6	Hexagon AB	HEXAb	118	Technology - Software & Services	Adam Wood	Europe	Enabler
7	SMIC	0981	17	Great China Technology Semiconductors	Charlie Chan	Asia ex-Japan	Enabler
8	TSMC	2330	945	Great China Technology Semiconductors	Charlie Chan	Asia ex-Japan	Enabler
9	Will Semiconductor Co Ltd	603501	100	Great China Technology Semiconductors	Charlie Chan	Asia ex-Japan	Enabler
10	Contemporary Amperex Technology	300750	186	China Energy & Chemicals	Jack Lu	Asia ex-Japan	Enabler
11	Ambarella Inc	AMBA	54	Semiconductors	Joseph Moore	United States	Enabler
12	NVIDIA	NVDA	118	Semiconductors	Joseph Moore	United States	Enabler
13	NXP Semiconductor NV	NXP	14	Semiconductors	Joseph Moore	United States	Enabler
14	On Semiconductor Corp.	ON	68	Semiconductors	Joseph Moore	United States	Enabler
15	Qualcomm Inc.	QCOM	201	Semiconductors	Joseph Moore	United States	Enabler
16	Renesas Electronics	6723	2,978	Japan Semiconductors	Kazuo Yoshikawa	Japan	Enabler
17	Socionext	6526	3,871	Japan Semiconductors	Kazuo Yoshikawa	Japan	Enabler
18	ARM Holdings PLC	ARM	151	Technology - European Semiconductors	Lee Simpson	Europe	Enabler
19	Cadence Design Systems Inc	CDNS	309	Semiconductors	Lee Simpson	United States	Enabler
20	Infineon Technologies AG	IFXG	34	Technology - European Semiconductors	Lee Simpson	Europe	Enabler
21	STMicroelectronics NV	STMPA	37	Technology - European Semiconductors	Lee Simpson	Europe	Enabler
22	Synopsys Inc.	SNPS	596	Semiconductors	Lee Simpson	United States	Enabler
23	Harmonic Drive Systems	6324	4,475	Factory Automation (Japan)	Lisa Jiang	Japan	Enabler
24	NSK	6471	779	General Machinery (Japan)	Lisa Jiang	Japan	Enabler
25	NTN	6472	313	General Machinery (Japan)	Lisa Jiang	Japan	Enabler
26	Siemens	SIEGn.DE	170	Capital Goods (Europe)	Max Yates	Europe	Enabler
27	Naver Corp	35420	168,400	South Korea Telecoms, Media & Internet	Seyon Park	Asia ex-Japan	Enabler
28	Samsung Electronics	5930	81,300	South Korea Technology	Shawn Kim	Asia ex-Japan	Enabler
29	Samsung SDI	6400	369,000	South Korea Technology	Shawn Kim	Asia ex-Japan	Enabler
30	SK hynix	660	237,000	South Korea Technology	Shawn Kim	Asia ex-Japan	Enabler
31	Ningbo Tuopu Group Co Ltd	601689	57	China Autos & Shared Mobility	Shelley Wang	Asia ex-Japan	Enabler
32	Zhejiang Sanhua Intelligent Controls	2050	23	China Autos & Shared Mobility	Shelley Wang	Asia ex-Japan	Enabler
33	Jiangsu Hengli Hydraulic Co.Ltd	601100	49	China Industrials	Sheng Zhong	Asia ex-Japan	Enabler
34	Leader Harmonious Drive Systems	688017	82	China Industrials	Sheng Zhong	Asia ex-Japan	Enabler
35	LG Energy Solution	373220	331,000	South Korea Autos & Shared Mobility	Young Suk Shin	Asia ex-Japan	Enabler
36	SK Innovation	96770	109,000	South Korea Energy & Materials	Young Suk Shin	Asia ex-Japan	Enabler
<b>Beneficiary</b>							
37	Ford Motor Company	F	12	Autos & Shared Mobility	Adam Jonas	United States	Beneficiary
38	General Motors Company	GM	46	Autos & Shared Mobility	Adam Jonas	United States	Beneficiary
39	Dominos Pizza Inc.	DPZ	533	Restaurants	Brian Harbour	United States	Beneficiary
40	McDonald's Corporation	MCD	260	Restaurants	Brian Harbour	United States	Beneficiary
41	Amazon.com, Inc.	AMZN	186	Internet - E-commerce/Gig Economy	Brian Nowak	United States	Beneficiary
42	DHL Group	DHL	38	Transport (Europe)	Cedar Ekblom	Europe	Beneficiary
43	DSV A/S	DSV	1,091	Transport (Europe)	Cedar Ekblom	Europe	Beneficiary
44	Kuehne und Nagel International AG	KNIN	258	Transport (Europe)	Cedar Ekblom	Europe	Beneficiary
45	China Railway Group	0390	4	China Industrials	Chelsea Wang	Asia ex-Japan	Beneficiary
46	China State Construction Engineering	601668	5	China Industrials	Chelsea Wang	Asia ex-Japan	Beneficiary
47	Baker Hughes Company	BKR	34	Oilfield Services	Daniel Kutz	United States	Beneficiary
48	Halliburton Company	HAL	34	Oilfield Services	Daniel Kutz	United States	Beneficiary
49	SLB	SLB	47	Oilfield Services	Daniel Kutz	United States	Beneficiary
50	Tenaris S.A. Sponsored	TS	31	Oilfield Services	Daniel Kutz	United States	Beneficiary
51	JD.com, Inc.	JD	28	China Internet and Other Services	Eddy Wang	Asia ex-Japan	Beneficiary
52	Haidilao International Holding Ltd	6862	15	China/Hong Kong Consumer	Hildy Ling	Asia ex-Japan	Beneficiary
53	BMW	BMWG	90	Autos & Shared Mobility	Javier Martinez	Europe	Beneficiary
54	Mercedes-Benz Group AG	MBGn	65	Autos & Shared Mobility	Javier Martinez	Europe	Beneficiary
55	BGF Retail	282330	106,000	South Korea Consumer	Kelly Kim	Asia ex-Japan	Beneficiary
56	GS Retail Co Ltd	7070	21,300	South Korea Consumer	Kelly Kim	Asia ex-Japan	Beneficiary
57	Lotte Shopping	23530	63,700	South Korea Consumer	Kelly Kim	Asia ex-Japan	Beneficiary
58	Yum China Holdings Inc.	YUMC	32	China/Hong Kong Consumer	Lillian Lou	Asia ex-Japan	Beneficiary
59	Knight-Swift Transportation Holdings Inc.	KNX	49	Transportation - Freight and Airlines	Ravi Shanker	United States	Beneficiary
60	Werner Enterprises, Inc.	WERN	36	Transportation - Freight and Airlines	Ravi Shanker	United States	Beneficiary
61	Stellantis	STLA	21	Autos & Shared Mobility	Ross MacDonald	Europe	Beneficiary
62	Obayashi	1802	1,831	Construction (Japan)	Ryo Yagi	Japan	Beneficiary
63	Shimizu	1803	901	Construction (Japan)	Ryo Yagi	Japan	Beneficiary
64	Taisei	1801	5,820	Construction (Japan)	Ryo Yagi	Japan	Beneficiary
65	Coupang Inc.	CPNG	21	South Korea Telecoms, Media & Internet	Seyon Park	Asia ex-Japan	Beneficiary
66	BYD Company Limited	1211	240	China Autos & Shared Mobility	Tim Hsiao	Asia ex-Japan	Beneficiary

Source: Morgan Stanley Research

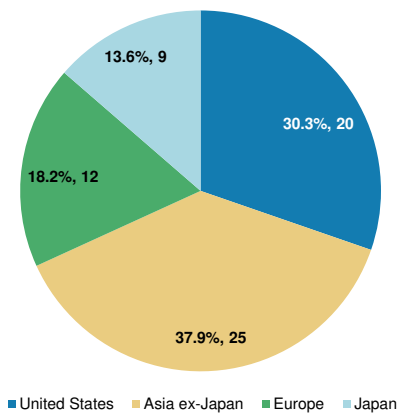
Note: Prices are in local currency as of close on June 25, 2024.

Exhibit 18: Humanoid 66: Enablers and Beneficiaries



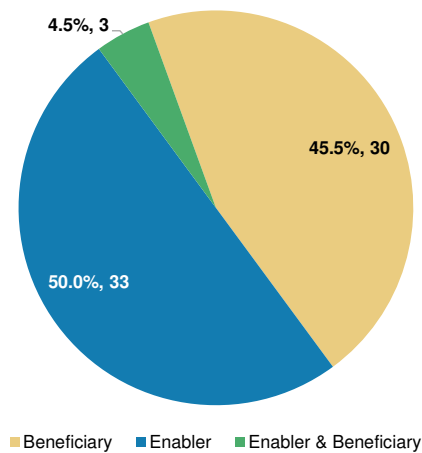
Source: Morgan Stanley Research

**Exhibit 19:** Humanoid 66 by Region



Source: Morgan Stanley Research

**Exhibit 21:** Humanoid 66 by Classification: Enabler, Beneficiary, or Enabler & Beneficiary



Source: Morgan Stanley Research

**Exhibit 20:** Humanoid 66 by Region

Country	Count	Percent
United States	20	30.3%
Asia ex-Japan	25	37.9%
Europe	12	18.2%
Japan	9	13.6%
<b>Total</b>	<b>66</b>	<b>100.0%</b>

Source: Morgan Stanley Research

**Exhibit 22:** Humanoid 66 by Classification: Enabler, Beneficiary, or Enabler & Beneficiary

Classification	Count	Percent
Beneficiary	30	45.5%
Enabler	33	50.0%
Enabler & Beneficiary	3	4.5%
<b>Total</b>	<b>66</b>	<b>100%</b>

Source: Morgan Stanley Research

# Scenario Framework: Labor Shortage Meets AI

**A leaked Amazon memo from mid-2021 cites labor shortage as the biggest bottleneck in industrial manufacturing and warehousing:**

*"If we continue business as usual, Amazon will deplete the available labor supply in the US network by 2024."*

We believe that companies with large warehouse logistics and manufacturing labor footprints will move the needle on humanoid robotics. Amazon's annual warehouse turnover is ~150% — and industry-wide warehouse turnover is ~50%. However these companies address humanoid replacement will likely affect the industry-wide path to commercialization. Geofenced humanoids in factory work cells present little to no safety concerns, and hitting pre-identified KPIs (such as human parity performance over the course of a full shift on throughput), will be the key unlock.

To help frame our humanoid thesis, we establish a framework (and corresponding simple equation) to distill our central narrative to investors: **Humanoids are the product of labor shortage and AI<sup>2</sup>, where the greater the labor shortage and the greater the acceleration of AI, the greater the need for humanoids.**

**Exhibit 23:** Humanoid Equation

$$\text{Humanoids} = \text{Labor Shortage} \times \text{AI}^2$$


Source: Morgan Stanley Research

## Scenario Framework

We acknowledge that AI acceleration is already materializing in new capital formation, product origination, and investor interest, which is why we add the Robotics element to our AI acceleration Y-axis. Our X-axis represents labor, not just labor availability in terms of supply, but also labor inflation, strike risk, and occupational hazards (repetitive, boring, dangerous jobs). This is an illustrative framework and scenarios are not shown to scale on the orthogonal.

In our orthogonal, the AI / data & compute / neural network / LLMs make up the **"brains"** of the humanoid while the mechanical robotics / actuators / supply chains represent the **"body"** of the humanoid. While we already see the acceleration taking place in both public and private markets in the *brain* aspect, the adoption curve to reach the "Humanoid Bull Case" (following the green arrow from the current scenario to the upper right quadrant) will involve major advancements in the *body* — driving innovation of humanoid robots within the field of "Embodied AI."

*Our three core cases are as follows:*

**1. The Humanoid Bear Case:** In this case, we stay where we are in the lower left quadrant, where the physical robotics do not advance to the extent needed to replace human labor, and current labor availability is not a bottleneck.

**2. The Humanoid Base Case:** In our base case, we see tech changes occur but at a slower rate than ideal for widescale humanoid replacement, due mostly to hardware limitations (the body) and various social considerations presenting a bottleneck — not so much because of the learning (the brain). See our section on [Hurdles to Humanoid Adoption](#) for further discussion. In our base case, we also see pressure in the labor market long term, again not just in availability (which is on an industry/sector/geographic level), but also in inflation / unionization / etc. — see in-depth context on the global labor situation in [Labor Market and the Humanoid TAM](#).

**3. The Humanoid Bull Case:** Our bull case in the upper right quadrant is the culmination of both the long-term sustained labor pressure and tech change (in both body and brain) feeding each other into humanoid advancement.

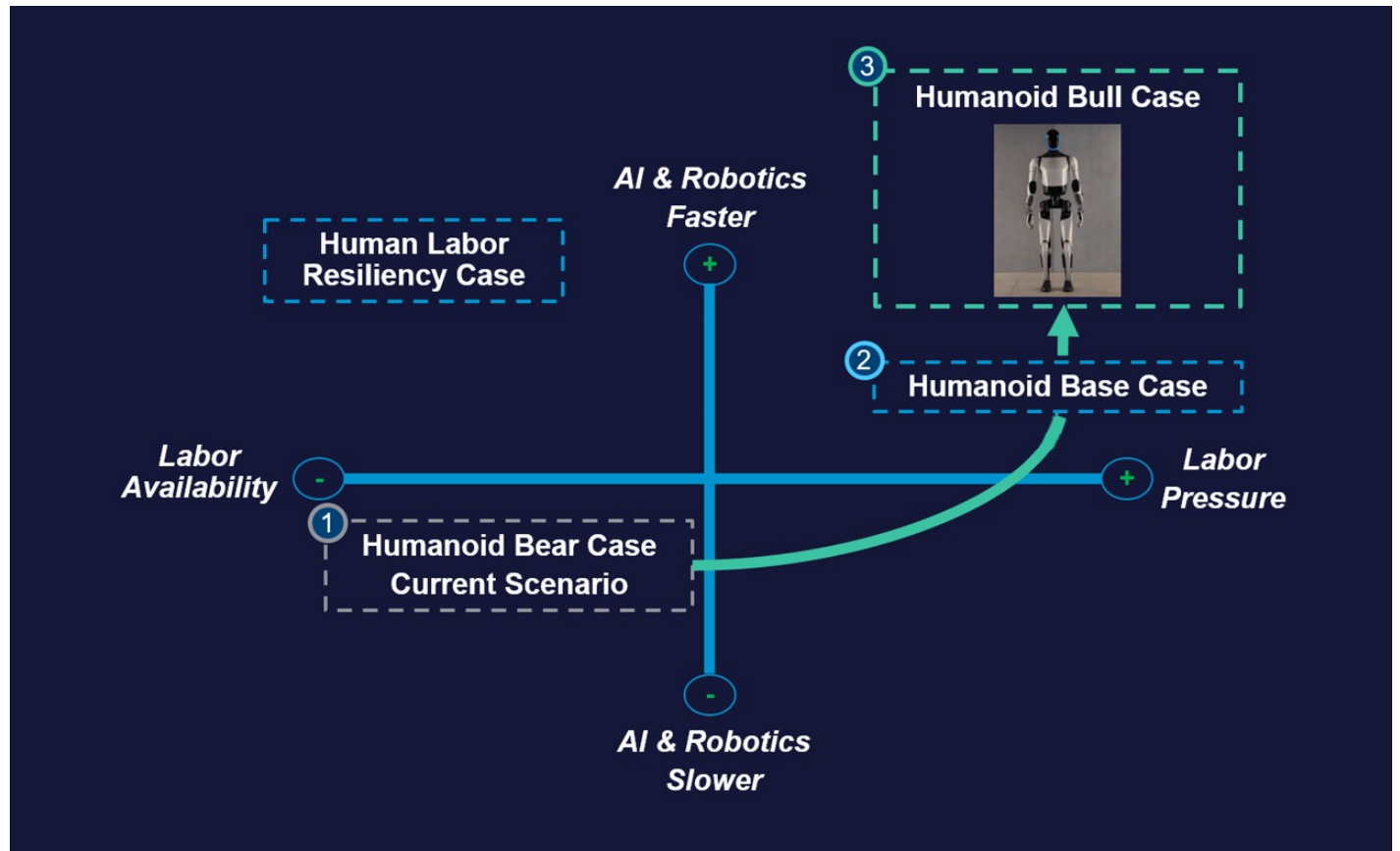


“ I want AI to do my laundry and dishes so that I can do art and writing, not for AI to do my art and writing so that I can do my laundry and dishes. ”

Joanna Maciejewka

Outside of our core three cases, we highlight a scenario outside of our adoption curve wherein availability of labor is not a bottleneck (global and US labor contextualized in aforementioned section ), either via a drastic change in immigration policy or slowdown in on-shoring (globalization for longer and slower transition to a multipolar world) ... all while technology for humanoids (both the "brain" and the "body") continues to progress. In this scenario, human labor remains "competitive" for longer.

Exhibit 24: Labor Availability vs. AI & Robotics Acceleration

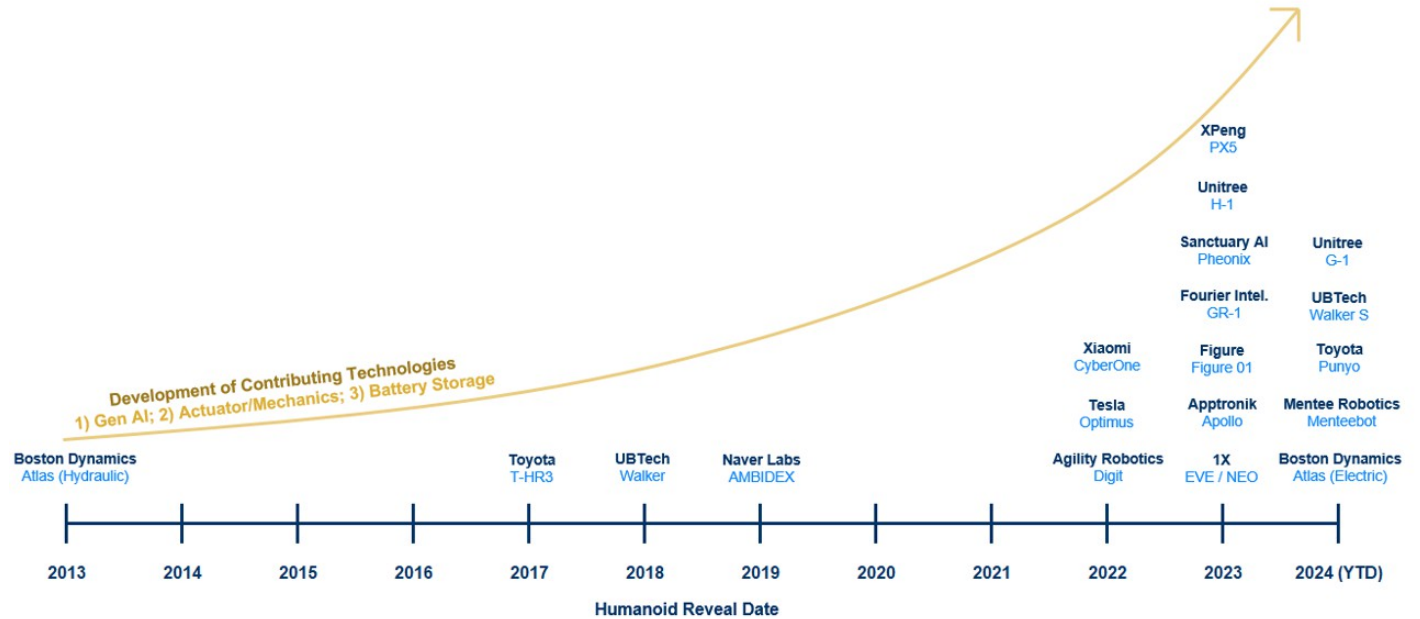


Source: Morgan Stanley Research

## Measuring Humanoid Progress

While intelligent humanoid development remains in early stages, we believe the path of progress over the past decade in the adjacent areas of 1) gen AI, 2) actuators & mechanics, and 3) battery storage have proven to be a significant accelerant to humanoid development. Further advancements in these three areas will be key to achieving humanoid commercialization.

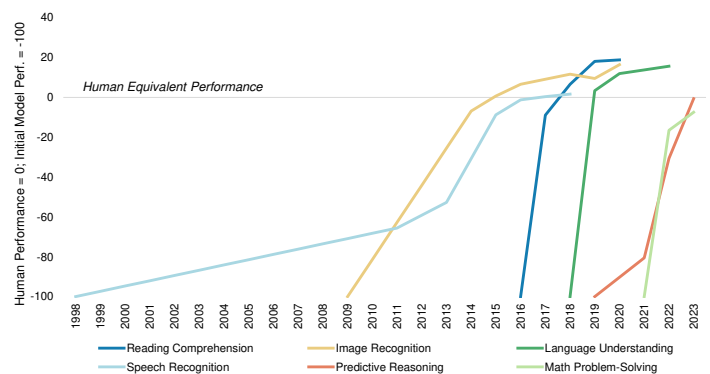
**Exhibit 25:** As contributing technologies have advanced over the past decade, intelligent humanoid development has continually increased in relevance.



Source: Company Data, Morgan Stanley Research

**1) Gen AI:** Modern humanoid development has been underway since the mid-20th century. However, the accelerating growth of Gen AI is arguably the single most important "unlock" enabling the increasing relevancy of humanoids in recent years, directly catalyzing the sizable number of new humanoid ventures launched since 2022. The growth in AI drastically increases the potential for humanoids to manage complex and nuanced scenarios frequently encountered in the human workplace, and also increases the robots' ability to utilize the more complex arrangements of sensors/vision/actuators needed to make humanoids commercially viable. Today, the vast majority of leading humanoid startups are partnered with one or more AI players (NVIDIA, OpenAI, Baidu, etc.). As the "embodiment of AI," we foresee a close linkage between the development curves of humanoid robots and gen AI. See the "[Humanoid Robotics and Capital Formation](#)" section and our global Thematics team's "[Venture Vision: Robotics All The Rage](#)" note for further details.

**Exhibit 26:** Test Scores of Prevalent AI Models on Various Capabilities Relative to Human Performance

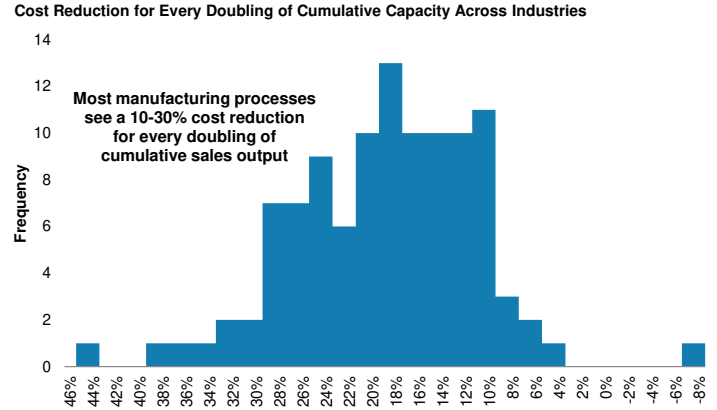


Note: Human performance, as the benchmark, is set to zero. The capability of each AI system is normalized to an initial performance of -1.

Source: Kiela et al. (2023) – with minor processing by Our World in Data, Morgan Stanley Research

**2) Actuators & Mechanics:** Developments to the physical humanoid "body" (actuators, sensors, etc.), have and should continue to enable increasingly complex humanoid designs. As described in detail in the "[Anatomy of a Humanoid: Mapping the Supply Chain](#)" section, newer refinements in actuator/sensor technologies such as planetary-roller screws, coreless motors, harmonic reducers, and six-axis force sensors have become commonplace on advanced humanoid designs. While utilizing a multitude of newer, more complex components can quickly inflate production costs, under [Wright's Law](#), most manufacturing processes have historically experienced a 10-30% cost reduction for each doubling in cumulative output. With the introduction of highly-capable and cost-effective humanoid components sourced from China, we see a potential for humanoids to experience levels of cost reduction above what would otherwise be expected.

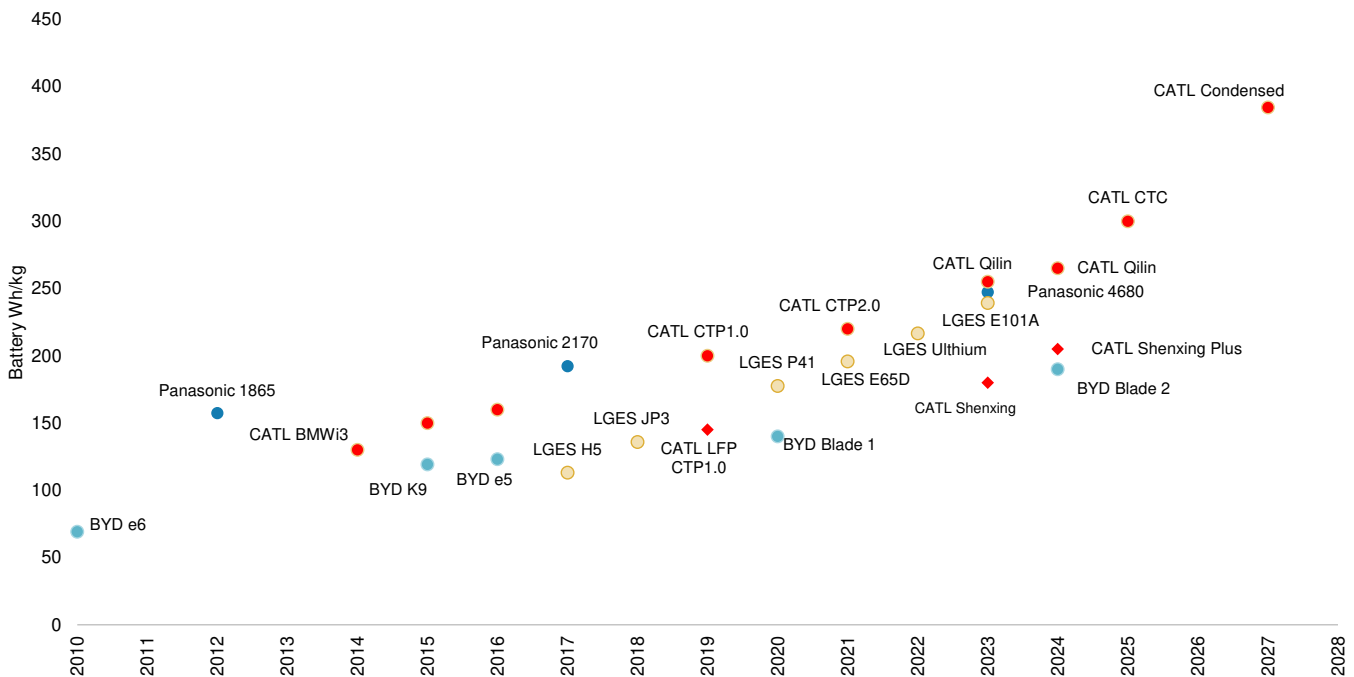
**Exhibit 27:** [Wright's Law](#) has been extensively examined in empirical study – that most manufacturing processes in a wide range of industries see 10-30% unit cost reduction for every doubling of cumulative sales output.



Source: ICEAA, Morgan Stanley Research.

**3) Battery Storage:** As humanoid developers increase the compute power and dexterity of any robot, teams must continually address the issue of rising power requirements. Today, modern humanoids generally have battery lives of 1-3 hours when in operation. However, notably higher uptimes may be needed to make humanoids commercially viable. As addressed in "[Will Moore's Law Apply to Batteries?](#)" published by our Asia Battery Team, new battery developments over the past decade+ have gradually increased energy density by ~20% every two years. At this pace, commercialization of solid-state batteries (potentially the next "unlock" for humanoid battery capacity) could take place by 2028-30. We also note there is a clear overlap between batteries designed for electric vehicles and ones likely to be used on humanoids. For example, Tesla's Optimus utilizes battery technology from the company's auto and energy businesses, allowing it to be produced using the Tesla's existing supply chain and infrastructure. See "[Appendix I —Humanoid Robots: The World of Physical AI](#)" for further details.

**Exhibit 28:** The "Moore's Law" of Batteries? Battery pack energy density increases by 20% about every two years.








Source: Morgan Stanley Research

## Hurdles to Humanoid Adoption

**Despite the AI and labor tailwinds that we believe will drive future humanoids adoption, there are still a number of hurdles that may limit the speed of adoption:**

- **Mechanics-related:** Despite decades of modern robotics development, the adoption of humanoids may require continued advancements in mechanical/electrical engineering and material science to enable the basic (walking, running, etc.) and fine (fingers, hands) motor skills required to accomplish a wide array of human tasks. Potential technological needs include highly refined actuator designs, precise multi-modal sensors, and synthetic materials that prioritize strength and weight reduction.
- **Uptime-related:** In order for humanoids to be realistic investments, they need to be reliable and must not require an operationally-infeasible amount of downtime to charge and/or repair. Most humanoids currently in development have advertised battery lives of only a few hours, and additional battery innovation may be required to support the energy required to execute complex and highly physical tasks. Additionally, we note that the humanoid industry (similar to the auto industry), may require a capable parts and repair network to maximize uptime for operators.
- **Cost-related:** Any costs related to the development and production of humanoids must not result in selling prices that provide an unrealistic payback to operators. While there will likely be cost-related benefits to scaling production, additional technological developments may be required to minimize component costs (see our "[Assessing the Humanoid Bill-of-Materials](#)" section). We currently believe humanoids can prove to be highly profitable, but note they may also eventually cost significantly higher than we expect given that humanoid development is constantly evolving. Additionally, operational costs, particularly related to the electricity required to power humanoids and their associated AI models will need to be realistic for operators. See "[What Goes into a Humanoid Robot?](#)"
- **AI-related:** Creating humanoids with the intelligence required to navigate the nuances of complex human environments/tasks will likely require continued advancements in gen-AI and work to tailor the models to be used on humanoids. We currently remain encouraged by the range of partnerships emerging between AI and humanoid players (OpenAI and NVIDIA, among others are actively working with various humanoid startups).
- **Social-related:** We note that potentially disrupting a significant amount of the global workforce will likely result in some degree of social and political pushback which humanoid developers and adopters will need to navigate. Additionally, using autonomous vehicles as a case study, we believe there may be a range of safety requirements that developers may need to meet in order for humanoids to be implemented in certain workplaces as well as households. However, in contrast to autonomous vehicles, we believe the ability to train humanoids using digital twins or closed-off, geo-fenced work cells, as opposed to public streets, gives humanoids a relative advantage when approaching potential safety regulations.

**Exhibit 29:** Potential Hurdles to Humanoid Adoption

<b>Hurdles To Humanoid Adoption</b>	
 <b>Mechanics</b>	<ul style="list-style-type: none"><li>• Precision actuators for delicate manipulation</li><li>• Sensors capable of processing vast arrays of multimodal inputs</li><li>• Synthetic materials that prioritize both strength and light weight</li></ul>
 <b>Uptime</b>	<ul style="list-style-type: none"><li>• Limiting/predicting/detecting potential wear and tear</li><li>• Energy-dense batteries able to support the required operational times</li><li>• Efficient supply chains and repair networks</li></ul>
 <b>Cost</b>	<ul style="list-style-type: none"><li>• Component costs</li><li>• Energy &amp; operational costs</li></ul>
 <b>AI</b>	<ul style="list-style-type: none"><li>• Development of gen-AI models applicable to humanoids</li><li>• Efficient training both in physical environment &amp; w/ digital twins</li><li>• Navigating the nuance of human tasks and environments</li></ul>
 <b>Social</b>	<ul style="list-style-type: none"><li>• Satisfying various workplace and household safety regulations</li><li>• Political/social pushback to the elimination of jobs</li><li>• Humans learning to operate and work alongside humanoids</li></ul>

Source: Morgan Stanley Research



# Labor Market and the Humanoid TAM

**We use three approaches to identify sectors that are best positioned for humanoid adoption and size the potential total addressable market:**

**1. Top-down analysis.** We considered sectors that involve the greatest amount of boring, repetitive, or dangerous physical labor, and those that are most unionized or have the highest unit labor costs as best positioned.

**a. Takeaway:** *Based on this methodology, we reason that the sectors most exposed to humanoid optionality are transportation & warehousing, construction, manufacturing, agriculture/mining, and healthcare.*

**2. Bottom-up analysis.** We parsed through the Bureau of Labor Statistics' US employment list and evaluated the extent to which physical labor is required for each occupation (831 total US occupations). We considered the sectors that have the highest degree of physically intensive jobs as best positioned for adoption. Extrapolating the analysis, we created a TAM model that sizes the potential impact of humanoids on the US labor market from the perspective of wages and number of jobs.

**a. Takeaway:** *Based on our analysis, we believe ~75% of occupations and ~40% of employees in the US have some degree of "humanoidability." This amounts to an estimated addressable market of ~\$3 trillion, or ~63 million humanoid units in the US alone.*

**b. Total revenue analysis.** Using the results of our bottom-up analysis, we overlaid an average selling price per humanoid and a replacement rate assumption onto our units adoption analysis to estimate the total revenue generated by the US humanoids market each year

**i. Takeaway:** *We estimate that the US humanoids market could generate ~\$4 billion total revenue by 2030, ~\$240 billion total revenue by 2040, and ~\$1 trillion total revenue by 2050 (with rapid acceleration in revenue growth occurring in 2040-50).*

**c. Payback analysis.** For additional perspective on potential cost savings derived from employing a humanoid vs. a human laborer, we performed a payback analysis in which we calculated the difference between the cumulative cost of a human laborer vs. the cumulative cost of a humanoid over time.

**i. Takeaway:** *We estimate cost savings of ~\$500 thousand to \$1 million+ per human worker over a 20-year time frame.*

**3. Proprietary humanoid sector survey.** We asked each Morgan Stanley Research US sector analyst to assess the extent to which their coverage is exposed to humanoid disruption based on seven survey questions. We ranked each sector according to those that involve physically intensive or boring/repetitive/dangerous jobs, are facing labor shortages, or are already focused on automating physical work.

**a. Takeaway:** *Survey results indicated that sectors most suitable to humanoids include transportation & logistics, automotive, oilfield services, restaurants, and hard-lines/broadlines.*

Additionally, we look at longer-term labor supply headwinds, such as demographics, immigration, and fertility rates, which could be important factors in determining the relevance of humanoid substitution in the labor market.

**Synthesizing the results from our three approaches, we identify a number of sectors that screen exceptionally high with respect to humanoid substitution potential:**

- Autos
- Freight Transportation & Logistics
- Restaurants
- Oil & Gas
- *Additionally, there are adjacent sectors that involve extensive physical labor, which we also see as highly exposed; these include Construction and Warehousing (ex. e-Commerce companies that use warehouse/distribution centers).*

**Note, our framework is an illustrative representation of the sectors that could potentially be positioned for humanoid adoption.** We note that:

- Industries that may have tasks that can be performed by humanoids also tend to be lower cost, which could hamper the investment process to adopt embodied AI.
- Within each job, not all tasks will likely be able to be performed by humanoids.

- We do not yet know if the introduction of humanoids will cause a permanent inward shift of labor demand or create a new type of demand for labor. It is possible that the advent of humanoids could expand existing sectors or create entirely new sectors, which could open opportunities for further human or humanoid employment.

**Below, we outline the methodologies employed in each of our three approaches and the results.** For further details on the sectors that we view as most exposed to humanoid adoption, please see the case studies on Autos, Freight Transportation, Oil & Gas, and Restaurants in our [Sector Adjacencies section](#).

## Top-Down Analysis

### US Economics

**We identify the following characteristics that make a job more or less likely to be exposed to humanoid adoption:**

- **Most dangerous:** Transportation and warehousing, construction, healthcare, agriculture/forestry, manufacturing.
- **Most repetitive/boring:** Office administrative workers, manufacturing, transportation & warehousing, food services, professional and business services, financial services, cleaning/hygiene.
- **Highest unit labor costs:** Construction, transportation & warehousing, manufacturing, healthcare. Additionally, we highlight jobs with high unionization rates: Educational workers, protective services, construction, extraction (mining), transportation and material moving.

**Based on this methodology, we reason that the sectors most exposed to humanoid optionality are transportation & warehousing, construction, manufacturing, agriculture/mining, and healthcare.** Transportation and warehousing screen high for danger, repetition, and labor costs/unionization. Construction screens high for danger, high labor costs/unionization. Agriculture/mining screens high for danger and unionization. Healthcare screens high for danger and unit labor costs.

### Dangerous Jobs

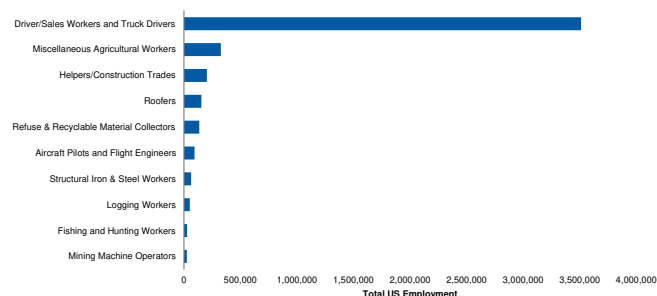
**The BLS report on illness and injuries finds that there were 2.8 million workplace injuries and illnesses (2.7 cases per 100 full-time workers) and 5,500 fatal work injuries (0.037 fatalities per**

**100 workers) in 2022 in the US.** Workplace injuries impact 1.8% of the US workforce and fatalities impact 0.003%. Work-related injuries account for most non-fatal injuries/illnesses (2.3/2.8 million) and work-related fatal injuries are largely driven by transportation-related incidents. Across fatal and non-fatal injuries, industries that are most dangerous and at risk of humanoid adoption would be transportation and material moving, healthcare, retail trade, and manufacturing.

**Occupations with the highest non-fatal illnesses/injuries are:** transportation and material moving occupations (410 cases per 10,000 workers) due to overexertion and bodily reaction, followed by health care and social assistance, arts/entertainment/recreation, and agriculture/forestry/fishing/hunting, retail trade, and manufacturing.

**The BLS “Census of Fatal Occupational Injuries” shows that industries that have the highest fatality rates are transportation & warehousing and construction, followed by professional & business services (which includes protective service occupations), agriculture/forestry/fishing/hunting, and manufacturing.**

**Exhibit 30:** Total Employment in Jobs with Highest Workplace Fatality Rate



Source: BLS, Morgan Stanley Research

**The specific occupations with the highest fatality rate:** Logging (fatality rate is 100.7/100,000 workers), roofers (57.5), fishing and hunting (50.9), helpers/construction trades (38.5), aircraft pilots/flight engineers (35.9), truck drivers (30.4), refuse and recyclable material collectors (22.6), structural iron and steel workers (21.6), underground mining machine operators (20.1), and miscellaneous agricultural workers (20). The civilian occupations that are more hazardous account for ~3% of employment in the US, as of 2023. The dangerous occupations that are the largest are truck drivers (3.5 million workers), miscellaneous agricultural workers (330k), helper/construction trades (192k), aircraft pilots/engineers (146k), and recyclable material collectors (135k).

“

We have to face the fact that countries are going to lose jobs to robotics. The only question that needs to be answered is which country will create and own the best robotic technology and have the infrastructure necessary to enable it.

”

Mark Cuban

## Repetitive & Boring Jobs

### **Repetitive motion is one leading cause for work-related injuries.**

Jobs that are more likely to involve repetitive motion include office jobs involving constant typing (office and administrative workers, computer programmers and developers), manufacturing jobs on assembly lines, construction jobs in building or demolition, stationary jobs requiring large amounts of time in one position (truck drivers, food pickers, tattoo artists), or jobs that require load-bearing (chefs, waitstaff, and bakers).

A [CNBC report](#) found the most boring jobs are data analysis, accounting, tax/insurance work, cleaning, and banking (!). *We note that, to the best of our knowledge, we are not aware of any humanoids who have contributed to the writing/preparation of this report.*

**The fastest declining occupations, according to the BLS, largely fit into the repetitive and boring categories and are quickly becoming automated.** These occupations include word processors and typists, roof bolters, mining, cutters and trimmers, telephone operators, switchboard operators, legal secretaries and admin assistants, textile workers, telemarketers, grinding and polishing workers, etc.

**There are still approximately 164k workers employed in these fast-declining occupations (0.1% of total workforce).**

*We show these examples of "declining" occupations to make the point that history is filled with precedents where automation and social evolution can drive profound changes in the type of work conducted by humans and where automation has continually transformed the landscape of work. See illustrative historical examples in our section [Obsolete Occupations](#). We do not mean to suggest that declining professions are more "ripe" for humanoid disruption.*

Exhibit 31: Occupations with Fastest Declining Workforce

Fastest Declining Occupations Projected Change 2022 to 2032 (Numbers in Thousands)	
2022 National Employment Matrix Title	Proj. Employment Change, (%) , 2022-32
<i>Total, all occupations</i>	2.8
Word processors and typists	-38.6
Watch and clock repairers	-29.8
Roof bolters, mining	-28.5
Cutters and trimmers, hand	-28.2
Telephone operators	-26.6
Data entry keyers	-26.0
Switchboard operators, including answering service	-25.1
Foundry mold and coremakers	-23.5
Legal secretaries and administrative assistants	-21.8
Pressers, textile, garment, and related materials	-21.8
Patternmakers, metal and plastic	-21.6
Refractory materials repairers, except brickmasons	-21.4
Executive secretaries and executive administrative assistants	-21.1
Manufactured building and mobile home installers	-21.0
Telemarketers	-20.6
Grinding and polishing workers, hand	-19.5
Engine and other machine assemblers	-18.9
Model makers, metal and plastic	-18.8
Timing device assemblers and adjusters	-18.7
Drilling and boring machine tool setters, operators, and tenders, metal and	-18.3
Order clerks	-18.2
Floral designers	-18.0
Electronic equipment installers and repairers, motor vehicles	-18.0
Loading and moving machine operators, underground mining	-17.7
Prepress technicians and workers	-17.1
Coil winders, tapers, and finishers	-16.6
Structural metal fabricators and fitters	-16.4
Payroll and timekeeping clerks	-16.4
Print binding and finishing workers	-16.4
File clerks	-16.0

Note: Uses precise name used by the BLS.

Source: BLS Employment Projections Program, Morgan Stanley Research

## High Unit Labor Cost Jobs

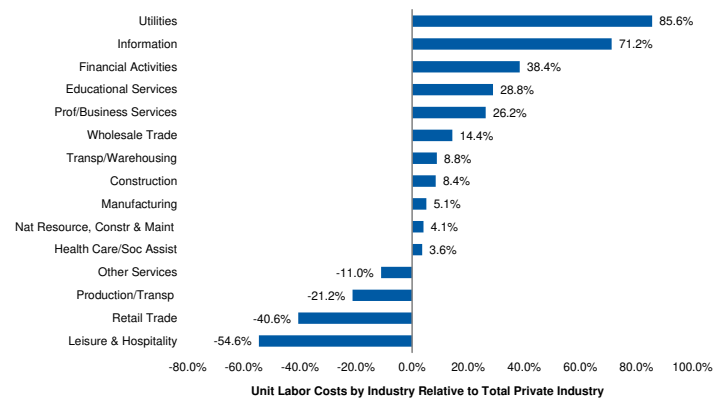
The industries with the highest unit labor cost (compensation per hour worked) are utilities, information services, financial activities, educational services, and professional and business services. However, we note many of these professions are less exposed to humanoids due to the nature of the tasks performed.

- Transportation & Warehousing 8.8% higher vs. the broader labor market unit labor costs
- Construction unit labor costs are 8.4% higher
- Manufacturing 5.1% higher
- Natural Resources 4.1% higher
- Health Care 3.6% higher

We note that unionized labor tends to have higher unit labor costs than non-unionized labor. Although unions have had a resurgence in recent years due to on-shoring and a tight labor market, the overall long-term trend for unionization is in decline. In 1985, 20% of employment was unionized work, compared to just 10% in 2023. Unions are most common among public sector workers — 32% of public sector workers are unionized, down from only 36% in 1985. Within the private sectors — unions exist in protective services (32%), construction & extraction (16%), community and social services occupations (14%), installation/maintenance/repair (13%), transportation and material moving (13%), educational workers (13% unionized). We want to make clear, we do not believe unionized workers are inherently more exposed to humanoids vs. non-unionized workers. However, unionized workers often have higher per unit labor costs which we do believe makes a job more exposed.

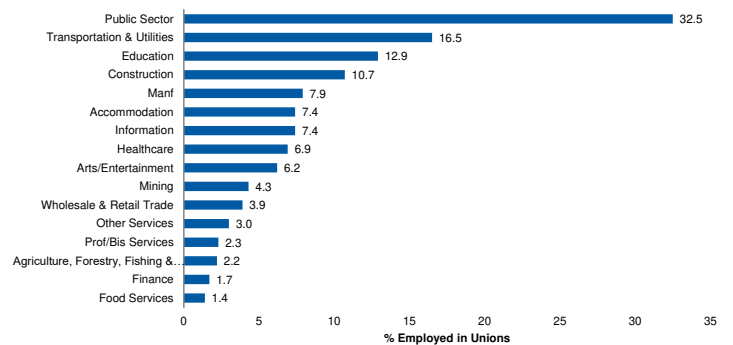
The median wages of unionized workers are 10% higher than non-unionized workers (down from 24% higher in 2000). The cost per hour worked for a union worker, however, is over 36% higher than the cost per hour for a non-unionized worker, due to fewer average working hours for union represented workers. Industries with the largest gap in median earnings between unionized vs. non-unionized workers are construction, transportation & warehousing, other services, and arts & entertainment.

Exhibit 32: Unit Labor Costs by Industry Relative to Total Private Industry



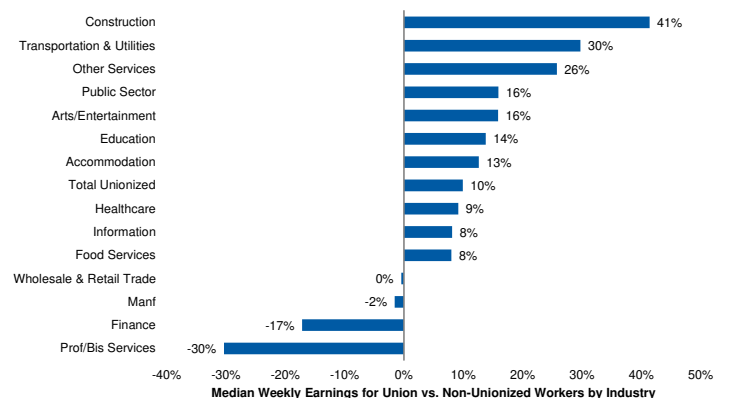
Source: BLS, Morgan Stanley Research

Exhibit 33: Unionization Penetration by Industry



Source: BLS, Morgan Stanley Research

Exhibit 34: Union vs. Non-Unionized Median Earnings Gap



Source: BLS, Morgan Stanley Research



## Bottom-Up Analysis

Note: The underlying Excel file for the TAM model discussed in this section is available upon request. Please reach out to your Morgan Stanley sales representative to obtain the model.

We conducted a bottom-up analysis on the US labor market to assess each occupation's "humanoidability" and estimate the humanoid TAM. We started by gathering all 831 US civilian occupations using the Bureau of Labor Statistics' [May 2023 Occupational Employment and Wage Statistics Survey](#). Working with our economics team, we assigned one of four 'values' to measure the humanoid optionality of each occupation as follows:

- **3 - Strong Potential (46% of occupations)**

- These are jobs that are predominately unskilled and most likely to be perceived as boring, dangerous, and/or repetitive. Extremely unlikely to be performed by an AI model due to physical requirements of the job.
- For the purposes of our TAM model, we assume **70%** of employees in these positions are substitutable with humanoids (i.e., 70% optionality factor).
- Jobs include: Warehouse Laborers, Stockers, Retail Salespeople, Security Guards, Fast Food Workers, Housekeepers, Inspectors/Testers, etc.

- **2 - Moderate Potential (9% of occupations)**

- These are jobs that are often physical in nature or which require a physical presence but are not necessarily unskilled or obviously perceived as boring, dangerous and/or repetitive.
- For the purposes of our TAM model, we assume **50%** of employees in these positions are substitutable with humanoids (i.e., 50% optionality factor).

- Jobs include: Cooks, Nursing Assistants, Patrol/Correctional Officers, Teachers, etc.

- **1 - Lower Potential (19% of occupations)**

- These are jobs that require complex human-to-human interaction or specialized skills not likely to be easily replicated by a robot (Ex: doctors, supervisors, engineers, etc.). A notable amount of these jobs are also more likely to be performed by an AI model rather than humanoid robots due to limited physical requirements.
- For the purposes of our TAM model, we assume **30%** of employees in these positions are substitutable with humanoids (i.e., 30% optionality factor).
- Jobs include: Restaurant/Retail Supervisors, Pharmacists, Physicians, Truck Drivers, Secretaries, etc.

- **0 - Limited Potential/NA (26% of occupations)**

- These are jobs that require a significant amount of complex human-to-human interaction or could more feasibly be performed by an AI model rather than a humanoid robot due to limited physical requirements.
- For the purposes of our TAM model, we assume **none** of the employees in these positions are substitutable with humanoids (i.e., 0% optionality factor).
- Jobs include: Accountants, Marketing Specialists, Lawyers, Computer Programmers, etc.

Using the 0-3 humanoid substitution risk framework, we multiplied the # of employees in each occupation by the relevant humanoid optionality factor and then by the median annual wage for the given occupation.

“

I am superior, sir, in many ways, but I would gladly give it up to be human.

”

Lt. Commander Data, *Star Trek*

**Based on our analysis, we believe ~75% of occupations and ~40% of employees in the US have some degree of "humanoidability." This amounts to an estimated addressable market of ~\$3 trillion, or ~63 million humanoid units in the US alone.** While this estimate considers only the US, we note that a TAM based on the global labor market could be greater by multitudes of magnitude.

- Transportation and Material Moving (estimated 55%, or 7.6 million employees)
- Production (estimated 68%, or 6.0 million employees)
- Sales and Related (estimated 43%, or 5.8 million employees)
- Healthcare Support (estimated 66%, or 4.6 million employees)

**The BLS industries with the highest % of humanoid optionality include:**

- Construction and Extraction (estimated 70%, or 4.4 million employees)
- Production (estimated 68%, or 6.0 million employees)
- Farming, Fishing, and Forestry (estimated 67%, or 0.3 million employees)
- Building and Ground Cleaning and Maintenance (estimated 67%, or 3.0 million employees)
- Installation, Maintenance, and Repair (estimated 66%, or 4.0 million employees)

**Note, this analysis does not imply that ~63 million people in the US will be jobless due to the advent of humanoids.** The analysis does not consider the realistic possibility that humanoids could expand the size/capacity of current industries (for example, increasing the number of households that have personal assistants or expanding the output of otherwise dangerous production activities). The analysis also does not consider the possibility that the introduction of humanoids could create entirely new industries, which could open new employment opportunities for human laborers. Simply, this analysis aims to illustrate the number of humanoids that could potentially be adopted to perform various jobs across a number of sectors. Broader conclusions regarding how humanoid labor could reshape existing industries or create new industries and jobs are beyond the scope of this analysis.

**The BLS industries with the highest number of potential humanoid adoptions, based on total size of industry, include:**

- Food Preparation and Serving Related (estimated 64%, or 8.4 million employees)

**Exhibit 35:** We estimate a \$3.0 trillion TAM for humanoid robots in the US alone and note that the global TAM could be multitudes of magnitude greater.

Substitution Level Legend					Key Outputs				
Case for Substitution	Sub. Level	Sub. %	# Occupations	% Job Line Items	Humanoid Impact				
					Jobs & Wages: Potential Impact	Total US	Replaceable	%	
Strong	3	70.0%	385	46.4%	Job Line Items	831	617	74%	
Medium	2	50.0%	71	8.6%	Industries	22	21	95%	
Mild	1	30.0%	160	19.3%	Employment Count (mn)	151.9	62.7	41%	
Not Attainable	0	0.0%	214	25.8%	Wage (\$mn)	8,983,047	2,957,377		
<b>Total</b>			<b>830</b>	<b>100.0%</b>					

Ranked by Replaceable Employee Count											
#	Industry	US # Occupations	US Total Employment Count (mn)	Humanoid Substitution Potential							Rank
				# Occupations	% Occupations	# Replaceable Employees (mn)	# Employees NOT Replaceable (mn)	% Employees Replaceable	% Employees NOT Replaceable	% of Total Replaceable Employees	
1	Food Preparation and Serving Related	17	13.2	17	100.0%	8.4	4.8	63.8%	36.2%	13.5%	1
2	Transportation and Material Moving	50	13.8	35	70.0%	7.6	6.1	55.4%	44.6%	12.2%	2
3	Production	105	8.8	105	100.0%	6.0	2.8	68.5%	31.5%	9.6%	3
4	Sales and Related	22	13.4	12	54.5%	5.8	7.6	43.5%	56.5%	9.3%	4
5	Healthcare Support	17	7.1	16	94.1%	4.6	2.4	65.7%	34.3%	7.4%	5
6	Office and Administrative Support	54	18.5	22	40.7%	4.4	14.1	23.9%	76.1%	7.1%	6
7	Construction and Extraction	60	6.2	60	100.0%	4.4	1.9	70.0%	30.0%	7.0%	7
8	Installation, Maintenance, and Repair	51	6.0	51	100.0%	4.0	2.0	66.1%	33.9%	6.3%	8
9	Healthcare Practitioners and Technical	71	9.3	63	88.7%	3.8	5.4	41.3%	58.7%	6.1%	9
10	Building and Grounds Cleaning and Maintenance	10	4.4	10	100.0%	3.0	1.4	67.3%	32.7%	4.8%	10
11	Educational Instruction and Libraries	64	8.7	35	54.7%	2.9	5.9	32.9%	67.1%	4.6%	11
12	Protective Service	24	3.5	23	95.8%	2.0	1.5	58.3%	41.7%	3.3%	12
13	Personal Care and Service	32	3.0	31	96.9%	1.9	1.2	61.1%	38.9%	3.0%	13
14	Management	38	10.5	28	73.7%	1.3	9.2	12.0%	88.0%	2.0%	14
15	Architecture and Engineering	36	2.5	29	80.6%	0.8	1.7	33.1%	66.9%	1.3%	15
16	Business and Financial Operations	32	10.1	8	25.0%	0.6	9.5	6.0%	94.0%	1.0%	16
17	Life, Physical, and Social Science	48	1.4	34	70.8%	0.5	0.9	38.7%	61.3%	0.9%	17
18	Farming, Fishing, and Forestry	13	0.4	13	100.0%	0.3	0.1	67.4%	32.6%	0.5%	18
19	Arts, Design, Entertainment, Sports, and Media	41	2.1	23	56.1%	0.2	1.9	11.3%	88.7%	0.4%	19
20	Community and Social Service	17	2.4	1	5.9%	0.0	2.4	1.1%	98.9%	0.0%	20
21	Legal	8	1.2	1	12.5%	0.0	1.2	1.8%	98.2%	0.0%	21
22	Computer and Mathematical	21	5.2	0	0.0%	0.0	5.2	0.0%	100.0%	0.0%	22
<b>Total</b>		<b>831</b>	<b>151.9</b>	<b>617</b>	<b>74.2%</b>	<b>62.7</b>	<b>89.2</b>	<b>41.3%</b>	<b>58.7%</b>	<b>100.0%</b>	<b>22</b>

Source: Bureau of Labor Statistics, Morgan Stanley Research

**Exhibit 36:** Summary of US Wage TAM by Sector (Ranked by Wage Impact)

Summary: Wage Impact by Sector		
#	Industry	Wage Impact (\$mn)
1	Transportation and Material Moving	313,572
2	Healthcare Practitioners and Technical	303,826
3	Food Preparation and Serving Related	269,188
4	Production	265,904
5	Construction and Extraction	246,790
6	Installation, Maintenance, and Repair	215,640
7	Sales and Related	197,731
8	Office and Administrative Support	194,048
9	Educational Instruction and Libraries	175,669
10	Healthcare Support	173,962
11	Management	138,567
12	Building and Grounds Cleaning and Maintenance	107,711
13	Protective Service	103,795
14	Architecture and Engineering	75,456
15	Personal Care and Service	63,874
16	Business and Financial Operations	50,585
17	Life, Physical, and Social Science	38,084
18	Farming, Fishing, and Forestry	10,833
19	Arts, Design, Entertainment, Sports, and Media	9,541
20	Legal	1,481
21	Community and Social Service	1,120
22	Computer and Mathematical	0
<b>Total</b>		<b>2,957,377</b>

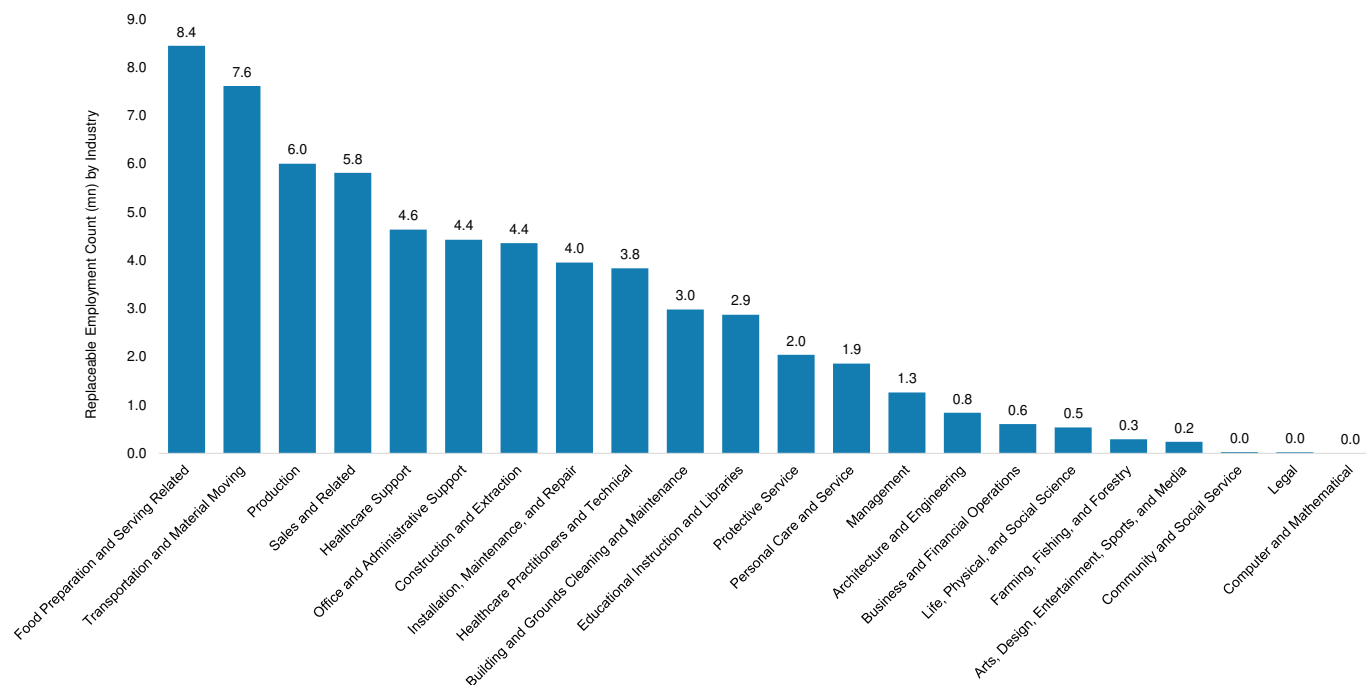
Source: Bureau of Labor Statistics, Morgan Stanley Research

**Exhibit 37:** Summary of US Labor Market Impact: Occupations, Industries, and Employment Count

Summary: Total Labor Market Impact			
Jobs & Wages: Potential Impact	Total US	Humanoid Impact	
		Adoptable	% of Total
Occupations	831	617	74%
Industries	22	21	95%
Employment Count (mn)	151.9	62.7	41%
<b>Wage (\$mn)</b>	<b>8,983,047</b>	<b>2,957,377</b>	

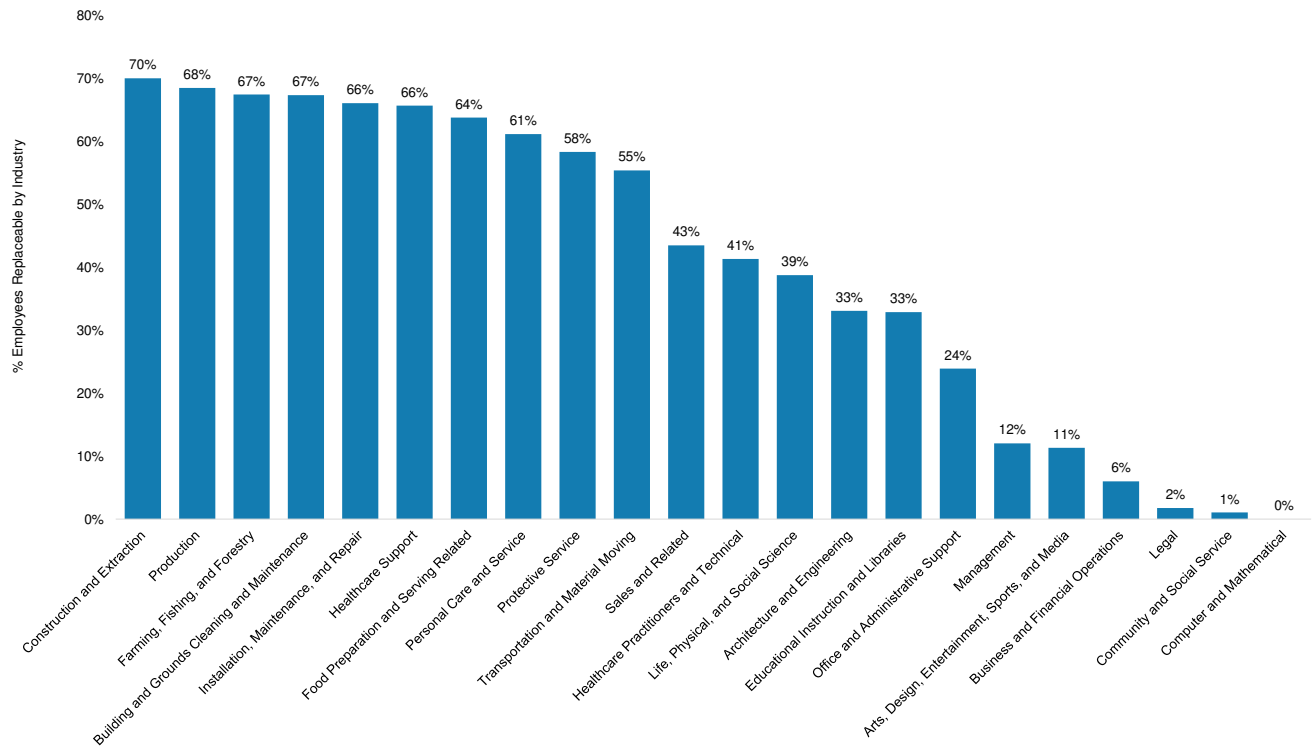
Source: Bureau of Labor Statistics, Morgan Stanley Research

**Exhibit 38:** US Industries Ranked by Number of Potential Humanoid Adoptions



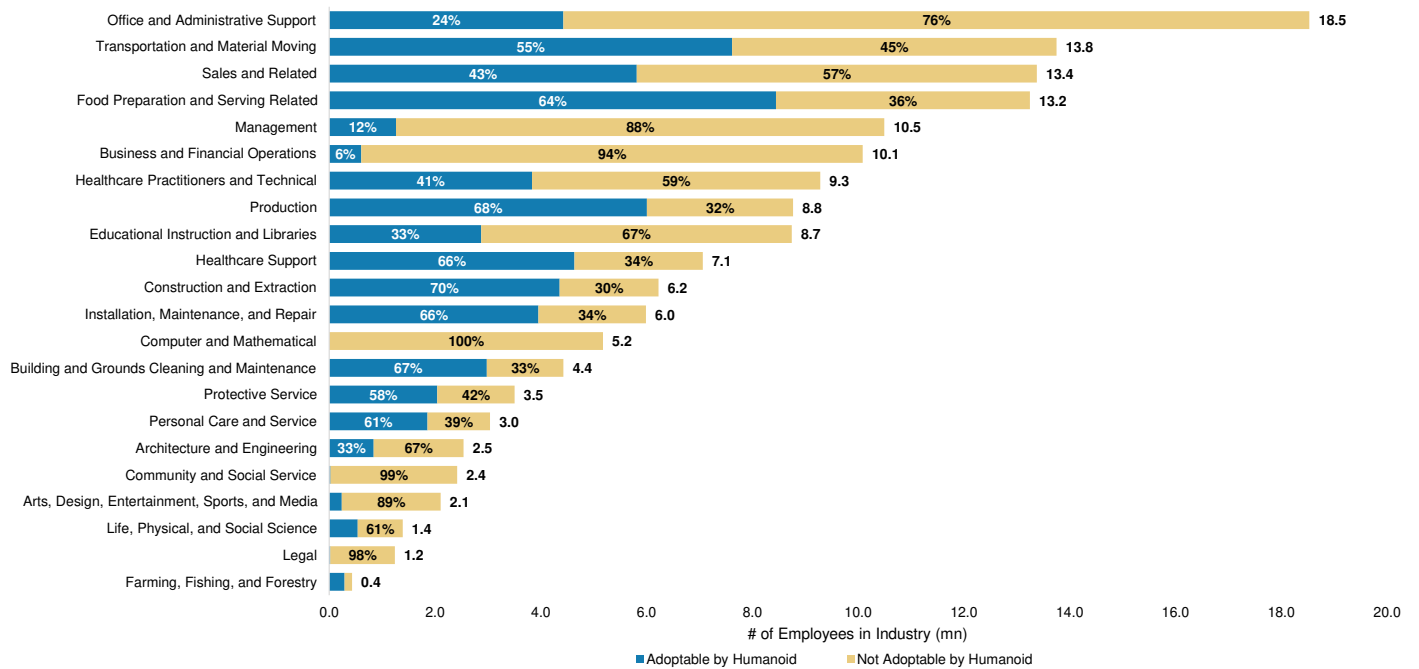
Source: Bureau of Labor Statistics, Morgan Stanley Research

**Exhibit 39:** US Industries Ranked by % of Humanoid Optionality



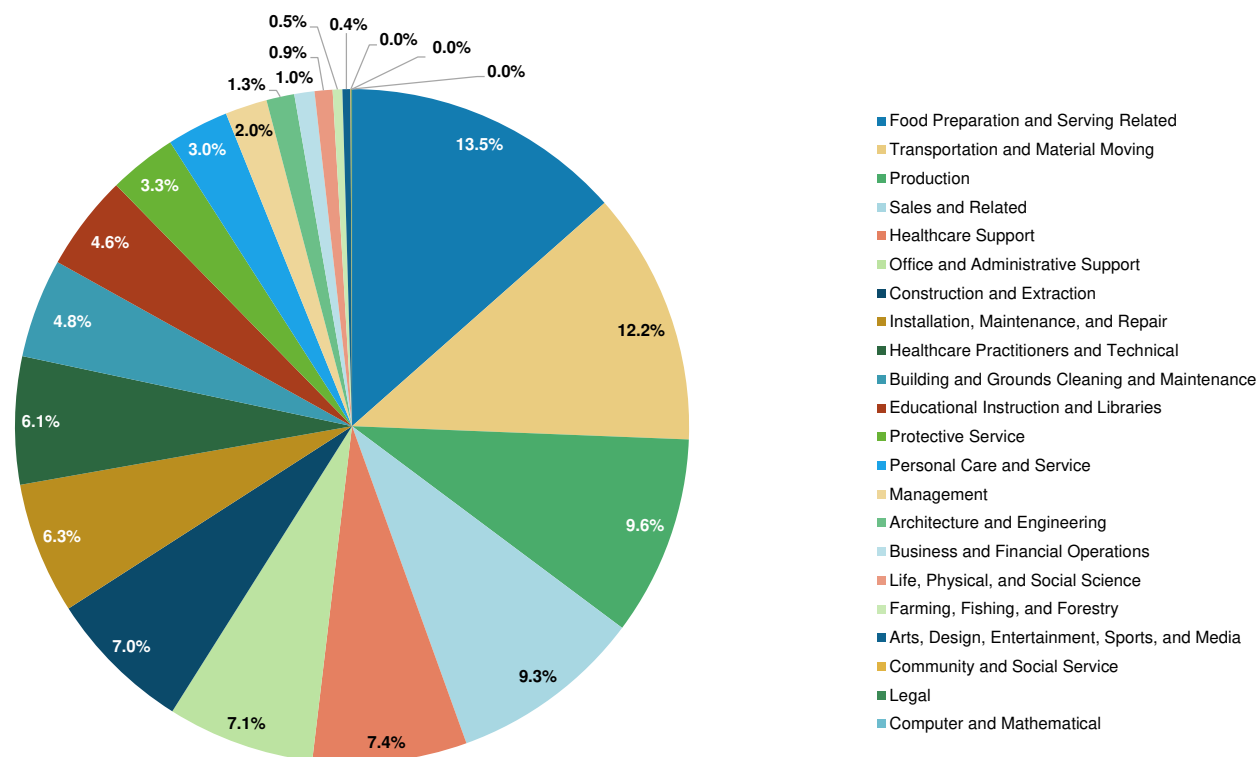
Source: Bureau of Labor Statistics, Morgan Stanley Research

**Exhibit 40:** Total Number of US Employees by Industry and % Substitutable by Humanoid



Source: Bureau of Labor Statistics, Morgan Stanley Research

**Exhibit 41:** Total US Humanoid Adoption by Industry (Shown as % of Total Potential Humanoid Units)



Source: Bureau of Labor Statistics, Morgan Stanley Research

We use a "timeline" framework to map the potential impact of humanoids on the US labor market between 2028 and 2050. The BLS employment list includes 22 distinct industries, of which we see 21 as having at least one occupation that is positioned for humanoid adoption (Computer and Mathematical is the only BLS industry for which we see limited risk of humanoid adoption for all occupations). We rank the BLS industries from greatest to least % of occupations exposed to humanoid adoption, and then group them into three "tiers":

- **Tier 1: Humanoid Adoption Optionality 60-70%.** Construction and Extraction; Production; Farming, Fishing, and Forestry; Building and Grounds Cleaning and Maintenance; Installation, Maintenance, and Repair; Healthcare Support; Food Preparation and Serving Related; Personal Care and Service
- **Tier 2: Humanoid Adoption Optionality 30-60%.** Protective Service; Transportation and Material Moving; Sales and Related; Healthcare Practitioners and Technical; Life, Physical, and Social Science; Architecture and Engineering; Educational Instruction and Libraries

- **Tier 3: Humanoid Adoption Optionality 0-30%.** Office and Administrative Support; Management; Arts, Design, Entertainment, Sports, and Media; Business and Financial Operations; Legal; Community and Social Service

**For perspective on how our estimated ~\$3 trillion TAM and ~63 million humanoid units could play out from 2030 to 2050, we assume that the first tier begins humanoid adoption in 2028; the second tier begins adoption in 2036; and the third tier begins adoption in 2040.** Using this framework, the industries that are most positioned for substitution (i.e., those that have the greatest % of humanoid optionality) are substituted first, followed by less exposed sectors (i.e., those that have a lower % of physically demanding occupations). We assume that each sector sees >1% of its adoptable workforce transition to humanoids in the initial years, followed by 5-20% in successive years.



According to our framework (illustrated in exhibits below):

- **By 2036, ~1.4 million (~2% of ~63 million total) humanoid adoptions will have occurred, amounting to a ~\$60 billion cumulative wage impact**
  - **Tier 1:** ~1.4 million total adoptions, ~\$60 billion cumulative wage impact
  - **Tier 2:** No adoptions, no wage impact
  - **Tier 3:** No adoptions, no wage impact
- **By 2040, ~8.4 million (~13% of ~63 million total) humanoid adoptions will have occurred, amounting to a ~\$226 billion cumulative wage impact**
  - **Tier 1:** ~7.6 million total adoptions, ~\$317 billion cumulative wage impact
  - **Tier 2:** ~800 thousand total adoptions, ~\$40 billion cumulative wage impact
  - **Tier 3:** No adoptions, no wage impact
- **By 2044, ~27 million (~43% of ~63 million total) humanoid adoptions will have occurred, amounting to a ~\$979 billion cumulative wage impact**
  - **Tier 1:** ~20 million total adoptions, ~\$831 billion cumulative wage impact
  - **Tier 2:** ~6.2 million total adoptions, ~\$318 billion cumulative wage impact
  - **Tier 3:** ~600 thousand total adoptions, ~\$34 billion cumulative wage impact
- **By 2050, ~63 million humanoid adoptions will have occurred, amounting to a ~\$3.0 trillion cumulative wage impact**
  - **Tier 1:** ~32.5 million total adoptions, ~\$1.3 trillion cumulative wage impact
  - **Tier 2:** ~23.6 million total adoptions, ~\$1.2 trillion cumulative wage impact
  - **Tier 3:** ~6.6 million total adoptions, ~\$395 billion cumulative wage impact

Exhibit 42: Summary of US Industry Tiering Methodology

		Ranked			
Tier	Industry	US Total Employment (mn)	# Adoptable (mn)	% Adoptable	
1	Construction and Extraction	6.2	4.4	70%	Adoption begins 2028
1	Production	8.8	6.0	68%	
1	Farming, Fishing, and Forestry	0.4	0.3	67%	
1	Building and Grounds Cleaning and Maintenance	4.4	3.0	67%	
1	Installation, Maintenance, and Repair	6.0	4.0	66%	
1	Healthcare Support	7.1	4.6	66%	
1	Food Preparation and Serving Related	13.2	8.4	64%	
1	Personal Care and Service	3.0	1.9	61%	
2	Protective Service	3.5	2.0	58%	Adoption begins 2036
2	Transportation and Material Moving	13.8	7.6	55%	
2	Sales and Related	13.4	5.8	43%	
2	Healthcare Practitioners and Technical	9.3	3.8	41%	
2	Life, Physical, and Social Science	1.4	0.5	39%	
2	Architecture and Engineering	2.5	0.8	33%	
3	Educational Instruction and Libraries	8.7	2.9	33%	Adoption begins 2040
3	Office and Administrative Support	18.5	4.4	24%	
3	Management	10.5	1.3	12%	
3	Arts, Design, Entertainment, Sports, and Media	2.1	0.2	11%	
3	Business and Financial Operations	10.1	0.6	6%	
3	Legal	1.2	0.0	2%	
3	Community and Social Service	2.4	0.0	1%	
N/A	Computer and Mathematical	5.2	0.0	0%	
<b>Total</b>		<b>151.9</b>	<b>62.7</b>	<b>41%</b>	

Source: Bureau of Labor Statistics, Morgan Stanley Research

Exhibit 43: Humanoid Substitution and US Wage Impact by Tier, 2030-50

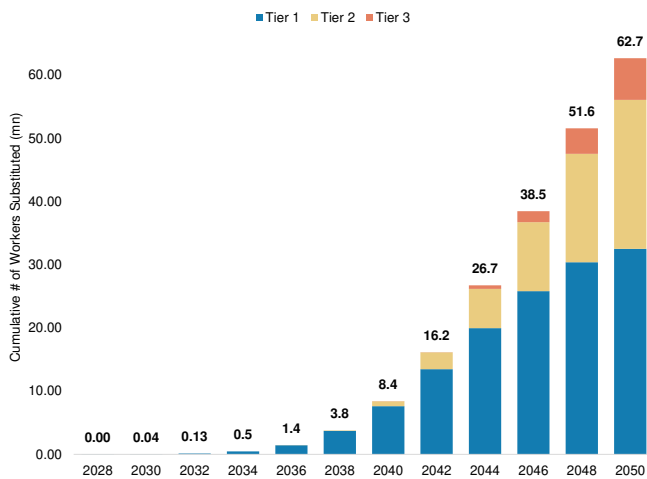
Substitutability Tier	% of Workers Substituted											
	2028	2030	2032	2034	2036	2038	2040	2042	2044	2046	2048	2050
1	0.01%	0.10%	0.30%	1.00%	3.00%	7.00%	12.00%	18.00%	20.00%	18.00%	14.00%	6.59%
2	0.00%	0.00%	0.00%	0.00%	0.01%	0.30%	3.00%	8.00%	15.00%	20.00%	26.50%	27.20%
3	0.00%	0.00%	0.00%	0.00%	0.00%	0.00%	0.01%	0.50%	8.00%	18.00%	35.00%	38.49%

Tier #	Industry	# of Humanoid Units Adopted (mn)											
		2028	2030	2032	2034	2036	2038	2040	2042	2044	2046	2048	2050
1	1 Construction and Extraction	0.0	0.0	0.0	0.0	0.1	0.3	0.5	0.8	0.9	0.8	0.6	0.3
1	2 Production	0.0	0.0	0.0	0.1	0.2	0.4	0.7	1.1	1.2	1.1	0.8	0.4
1	3 Farming, Fishing, and Forestry	0.0	0.0	0.0	0.0	0.0	0.0	0.0	0.1	0.1	0.1	0.0	0.0
1	4 Building and Grounds Cleaning and Maintenance	0.0	0.0	0.0	0.0	0.1	0.2	0.4	0.5	0.6	0.5	0.4	0.2
1	5 Installation, Maintenance, and Repair	0.0	0.0	0.0	0.0	0.1	0.3	0.5	0.7	0.8	0.7	0.6	0.3
1	6 Healthcare Support	0.0	0.0	0.0	0.0	0.1	0.3	0.6	0.8	0.9	0.8	0.6	0.3
1	7 Food Preparation and Serving Related	0.0	0.0	0.0	0.1	0.3	0.6	1.0	1.5	1.7	1.5	1.2	0.6
1	8 Personal Care and Service	0.0	0.0	0.0	0.0	0.1	0.1	0.2	0.3	0.4	0.3	0.3	0.1
1	<b>Substitutions, Annual (mn)</b>	<b>0.00</b>	<b>0.03</b>	<b>0.10</b>	<b>0.33</b>	<b>0.98</b>	<b>2.28</b>	<b>3.90</b>	<b>5.86</b>	<b>6.51</b>	<b>5.86</b>	<b>4.55</b>	<b>2.14</b>
1	<b>Cumulative Humanoid Units Adopted</b>	<b>0.00</b>	<b>0.04</b>	<b>0.13</b>	<b>0.46</b>	<b>1.43</b>	<b>3.71</b>	<b>7.62</b>	<b>13.47</b>	<b>19.98</b>	<b>25.84</b>	<b>30.39</b>	<b>32.54</b>
1	<b>% of 2050 Total</b>	<b>0%</b>	<b>0%</b>	<b>0%</b>	<b>1%</b>	<b>4%</b>	<b>11%</b>	<b>23%</b>	<b>41%</b>	<b>61%</b>	<b>79%</b>	<b>93%</b>	<b>100%</b>
2	9 Protective Service	0.0	0.0	0.0	0.0	0.0	0.0	0.1	0.2	0.3	0.4	0.5	0.6
2	10 Transportation and Material Moving	0.0	0.0	0.0	0.0	0.0	0.0	0.2	0.6	1.1	1.5	2.0	2.1
2	11 Sales and Related	0.0	0.0	0.0	0.0	0.0	0.0	0.2	0.5	0.9	1.2	1.5	1.6
2	12 Healthcare Practitioners and Technical	0.0	0.0	0.0	0.0	0.0	0.0	0.1	0.3	0.6	0.8	1.0	1.0
2	13 Life, Physical, and Social Science	0.0	0.0	0.0	0.0	0.0	0.0	0.0	0.0	0.1	0.1	0.1	0.1
2	14 Architecture and Engineering	0.0	0.0	0.0	0.0	0.0	0.0	0.0	0.1	0.1	0.2	0.2	0.2
2	15 Educational Instruction and Libraries	0.0	0.0	0.0	0.0	0.0	0.0	0.1	0.2	0.4	0.6	0.8	0.8
2	<b>Substitutions, Annual (mn)</b>	<b>0.0</b>	<b>0.0</b>	<b>0.0</b>	<b>0.0</b>	<b>0.0</b>	<b>0.1</b>	<b>0.7</b>	<b>1.9</b>	<b>3.5</b>	<b>4.7</b>	<b>6.2</b>	<b>6.4</b>
2	<b>Cumulative Humanoid Units Adopted</b>	<b>0.0</b>	<b>0.0</b>	<b>0.0</b>	<b>0.0</b>	<b>0.0</b>	<b>0.1</b>	<b>0.8</b>	<b>2.7</b>	<b>6.2</b>	<b>10.9</b>	<b>17.2</b>	<b>23.6</b>
2	<b>% of 2050 Total</b>	<b>0%</b>	<b>0%</b>	<b>0%</b>	<b>0%</b>	<b>0%</b>	<b>0%</b>	<b>3%</b>	<b>11%</b>	<b>26%</b>	<b>46%</b>	<b>73%</b>	<b>100%</b>
3	16 Office and Administrative Support	0.0	0.0	0.0	0.0	0.0	0.0	0.0	0.0	0.4	0.8	1.6	1.7
3	17 Management	0.0	0.0	0.0	0.0	0.0	0.0	0.0	0.0	0.1	0.2	0.4	0.5
3	18 Arts, Design, Entertainment, Sports, and Media	0.0	0.0	0.0	0.0	0.0	0.0	0.0	0.0	0.0	0.0	0.1	0.1
3	19 Business and Financial Operations	0.0	0.0	0.0	0.0	0.0	0.0	0.0	0.0	0.0	0.1	0.2	0.2
3	20 Legal	0.0	0.0	0.0	0.0	0.0	0.0	0.0	0.0	0.0	0.0	0.0	0.0
3	21 Community and Social Service	0.0	0.0	0.0	0.0	0.0	0.0	0.0	0.0	0.0	0.0	0.0	0.0
3	<b>Substitutions, Annual (mn)</b>	<b>0.0</b>	<b>0.0</b>	<b>0.0</b>	<b>0.0</b>	<b>0.0</b>	<b>0.0</b>	<b>0.0</b>	<b>0.0</b>	<b>0.5</b>	<b>1.2</b>	<b>2.3</b>	<b>2.5</b>
3	<b>Cumulative Humanoid Units Adopted</b>	<b>0.0</b>	<b>0.0</b>	<b>0.0</b>	<b>0.0</b>	<b>0.0</b>	<b>0.0</b>	<b>0.0</b>	<b>0.0</b>	<b>0.6</b>	<b>1.7</b>	<b>4.0</b>	<b>6.6</b>
3	<b>% of 2050 Total</b>	<b>0%</b>	<b>0%</b>	<b>0%</b>	<b>0%</b>	<b>0%</b>	<b>0%</b>	<b>0%</b>	<b>1%</b>	<b>9%</b>	<b>27%</b>	<b>62%</b>	<b>100%</b>
N/A	22 Computer and Mathematical	N/A	N/A	N/A	N/A	N/A	N/A	N/A	N/A	N/A	N/A	N/A	N/A
	<b>Total Humanoid Units Adopted, Annual (mn)</b>	<b>0.00</b>	<b>0.03</b>	<b>0.10</b>	<b>0.33</b>	<b>0.98</b>	<b>2.35</b>	<b>4.61</b>	<b>7.77</b>	<b>10.57</b>	<b>11.75</b>	<b>13.10</b>	<b>11.09</b>
	<b>Cumulative Humanoid Units Adopted (mn)</b>	<b>0.00</b>	<b>0.04</b>	<b>0.13</b>	<b>0.46</b>	<b>1.44</b>	<b>3.79</b>	<b>8.40</b>	<b>16.17</b>	<b>26.74</b>	<b>38.49</b>	<b>51.60</b>	<b>62.68</b>
	<b>% of 2050 Cumulative</b>	<b>0.0%</b>	<b>0.1%</b>	<b>0.2%</b>	<b>0.7%</b>	<b>2.3%</b>	<b>6.0%</b>	<b>13.4%</b>	<b>25.8%</b>	<b>42.7%</b>	<b>61.4%</b>	<b>82.3%</b>	<b>100.0%</b>

Tier #	Industry	Wage Impact (\$bn)											
		2028	2030	2032	2034	2036	2038	2040	2042	2044	2046	2048	2050
1	1 Construction and Extraction	0.0	0.2	0.7	2.5	7.4	17.3	29.6	44.4	49.4	44.4	34.6	16.3
1	2 Production	0.0	0.3	0.8	2.7	8.0	18.6	31.9	47.9	53.2	47.9	37.2	17.5
1	3 Farming, Fishing, and Forestry	0.0	0.0	0.0	0.1	0.3	0.8	1.3	1.9	2.2	1.9	1.5	0.7
1	4 Building and Grounds Cleaning and Maintenance	0.0	0.1	0.3	1.1	3.2	7.5	12.9	19.4	21.5	19.4	15.1	7.1
1	5 Installation, Maintenance, and Repair	0.0	0.2	0.6	2.2	6.5	15.1	25.9	38.8	43.1	38.8	30.2	14.2
1	6 Healthcare Support	0.0	0.2	0.5	1.7	5.2	12.2	20.9	31.3	34.8	31.3	24.4	11.5
1	7 Food Preparation and Serving Related	0.0	0.3	0.8	2.7	8.1	18.8	32.3	48.5	53.8	48.5	37.7	17.7
1	8 Personal Care and Service	0.0	0.1	0.2	0.6	1.9	4.5	7.7	11.5	12.8	11.5	8.9	4.2
1	<b>Wage Impact, Annual (\$bn)</b>	<b>0</b>	<b>1</b>	<b>4</b>	<b>14</b>	<b>41</b>	<b>95</b>	<b>162</b>	<b>244</b>	<b>271</b>	<b>244</b>	<b>190</b>	<b>89</b>
1	<b>Cumulative Wage Impact (\$bn)</b>	<b>0</b>	<b>1</b>	<b>6</b>	<b>19</b>	<b>60</b>	<b>154</b>	<b>317</b>	<b>561</b>	<b>831</b>	<b>1,075</b>	<b>1,265</b>	<b>1,354</b>
1	<b>% of 2050 Total</b>	<b>0%</b>	<b>0%</b>	<b>0%</b>	<b>1%</b>	<b>4%</b>	<b>11%</b>	<b>23%</b>	<b>41%</b>	<b>61%</b>	<b>79%</b>	<b>93%</b>	<b>100%</b>
2	9 Protective Service	0.0	0.0	0.0	0.0	0.0	0.3	3.1	8.3	15.6	20.8	27.5	28.2
2	10 Transportation and Material Moving	0.0	0.0	0.0	0.0	0.0	0.9	9.4	25.1	47.0	62.7	83.1	85.3
2	11 Sales and Related	0.0	0.0	0.0	0.0	0.0	0.6	5.9	15.8	29.7	39.5	52.4	53.8
2	12 Healthcare Practitioners and Technical	0.0	0.0	0.0	0.0	0.0	0.9	9.1	24.3	45.6	60.8	80.5	82.6
2	13 Life, Physical, and Social Science	0.0	0.0	0.0	0.0	0.0	0.1	1.1	3.0	5.7	7.6	10.1	10.4
2	14 Architecture and Engineering	0.0	0.0	0.0	0.0	0.0	0.2	2.3	6.0	11.3	15.1	20.0	20.5
2	15 Educational Instruction and Libraries	0.0	0.0	0.0	0.0	0.0	0.5	5.3	14.1	26.4	35.1	46.5	47.8
2	<b>Wage Impact, Annual (\$bn)</b>	<b>0</b>	<b>0</b>	<b>0</b>	<b>0</b>	<b>0</b>	<b>4</b>	<b>36</b>	<b>97</b>	<b>181</b>	<b>242</b>	<b>320</b>	<b>329</b>
2	<b>Cumulative Wage Impact (\$bn)</b>	<b>0</b>	<b>0</b>	<b>0</b>	<b>0</b>	<b>0</b>	<b>4</b>	<b>40</b>	<b>137</b>	<b>318</b>	<b>559</b>	<b>860</b>	<b>1,208</b>
2	<b>% of 2050 Total</b>	<b>0%</b>	<b>0%</b>	<b>0%</b>	<b>0%</b>	<b>0%</b>	<b>0%</b>	<b>3%</b>	<b>10%</b>	<b>23%</b>	<b>41%</b>	<b>65%</b>	<b>89%</b>
3	16 Office and Administrative Support	0.0	0.0	0.0	0.0	0.0	0.0	0.0	1.0	15.5	34.9	67.9	74.7
3	17 Management	0.0	0.0	0.0	0.0	0.0	0.0	0.0	0.7	11.1	24.9	48.5	53.3
3	18 Arts, Design, Entertainment, Sports, and Media	0.0	0.0	0.0	0.0	0.0	0.0	0.0	0.0	0.8	1.7	3.3	3.7
3	19 Business and Financial Operations	0.0	0.0	0.0	0.0	0.0	0.0	0.0	0.3	4.0	9.1	17.7	19.5
3	20 Legal	0.0	0.0	0.0	0.0	0.0	0.0	0.0	0.0	0.1	0.3	0.5	0.6
3	21 Community and Social Service	0.0	0.0	0.0	0.0	0.0	0.0	0.0	0.0	0.1	0.2	0.4	0.4
3	<b>Wage Impact, Annual (\$bn)</b>	<b>0</b>	<b>0</b>	<b>0</b>	<b>0</b>	<b>0</b>	<b>0</b>	<b>0</b>	<b>2</b>	<b>32</b>	<b>71</b>	<b>138</b>	<b>152</b>
3	<b>Cumulative Wage Impact (\$bn)</b>	<b>0</b>	<b>0</b>	<b>0</b>	<b>0</b>	<b>0</b>	<b>0</b>	<b>0</b>	<b>2</b>	<b>34</b>	<b>105</b>	<b>243</b>	<b>395</b>
3	<b>% of 2050 Total</b>	<b>0%</b>	<b>0%</b>	<b>0%</b>	<b>0%</b>	<b>0%</b>	<b>0%</b>	<b>0%</b>	<b>2%</b>	<b>8%</b>	<b>18%</b>	<b>29%</b>	<b>29%</b>
N/A	22 Computer and Mathematical	N/A	N/A	N/A	N/A	N/A	N/A	N/A	N/A	N/A	N/A	N/A	N/A
	<b>Total Wage Impact, Annual (\$bn)</b>	<b>0</b>	<b>1</b>	<b>4</b>	<b>14</b>	<b>41</b>	<b>98</b>	<b>199</b>	<b>342</b>	<b>484</b>	<b>556</b>	<b>648</b>	<b>570</b>
	<b>Cumulative Wage Impact (\$bn)</b>	<b>0</b>	<b>1</b>	<b>6</b>	<b>19</b>	<b>60</b>	<b>158</b>	<b>357</b>	<b>699</b>	<b>1,183</b>	<b>1,739</b>	<b>2,387</b>	<b>2,957</b>
	<b>% of 2050 Cumulative</b>	<b>0.0%</b>	<b>0.1%</b>	<b>0.2%</b>	<b>0.6%</b>	<b>2.0%</b>	<b>5.4%</b>	<b>12.1%</b>	<b>23.6%</b>	<b>40.0%</b>	<b>58.8%</b>	<b>80.7%</b>	<b>100.0%</b>

Source: Bureau of Labor Statistics, Morgan Stanley Research

**Exhibit 44:** Cumulative US Humanoid Adoption, 2028-50 (Millions of Humanoids)



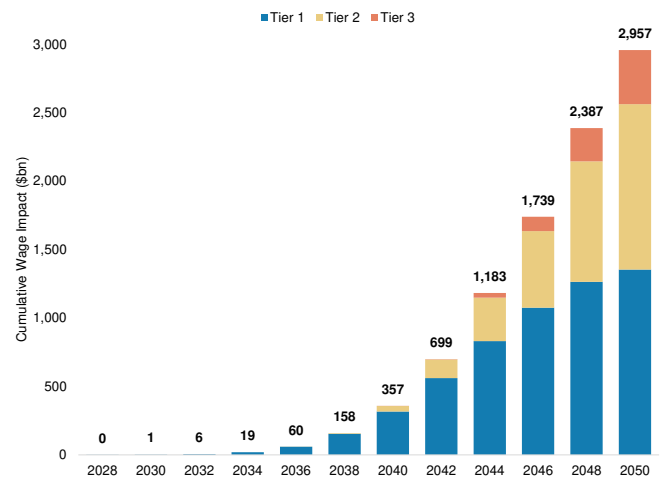
Source: Bureau of Labor Statistics, Morgan Stanley Research

**Overlaying an average selling price per humanoid and a replacement rate assumption onto our units adoption analysis, we estimate the total revenue generated by the US humanoids market each year.** We assume an initial average selling price per humanoid in 2028 of \$150k each, which declines to \$50k by ~2040. Post-2040, we assume a modest price increase of 0-1% per year driven by inflation offset by further technological advancements. We also assume a replacement rate of 8 years per humanoid. Based on these assumptions, we estimate that the US humanoids market could generate ~\$4 billion total revenue by 2030, ~\$240 billion total revenue by 2040, and ~\$1trillion total revenue by 2050 (with rapid acceleration in revenue growth occurring in 2040-50).

**Note, this analysis is an illustrative effort to depict how humanoids could potentially be adopted in certain industries and how the TAM could be captured over time.** Our "timeline" analysis also does not account for the possibility that the introduction of humanoids could create new sectors, expand existing sectors, or create new job opportunities for humans. For simplicity, the analysis also assumes no growth in the total size of the US labor market and its existing industries.

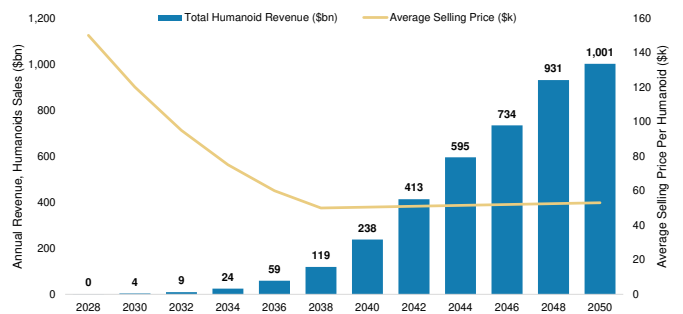
We note that the TAM analysis and adoption curve forecasts in this report are limited to civilian job classifications. Military/defense and police applications are not included within the scope of this report.

**Exhibit 45:** Cumulative US Wage Impact, 2028-50 (\$Billion)



Source: Bureau of Labor Statistics, Morgan Stanley Research

**Exhibit 46:** US Humanoids Market, Total Revenue (\$bn)



Source: Bureau of Labor Statistics, Morgan Stanley Research. Assumes 8-year replacement cycle.

That said, we acknowledge the US Defense Department (DoD) has invested heavily in the areas of AI, manned-unmanned teaming, and robotics, including in the realm of humanoid development. This includes Defense Advanced Research Projects Agency's (DARPA) Robotics Challenge (held 2013-15), which provided early learnings around technological maturation that have informed some of today's leading commercial offerings (link).

While discussion of the impact of robotics on warfare/law enforcement is beyond this report's scope, we note the Pentagon spends a discrete ~\$180 billion on Military Personnel annually, roughly ~20% of the overall DoD budget. Additionally, we note that based on the Defense Health Agency's most recent annual report (February 2024), nearly 700,000 non-deployed US soldiers sustained injuries in 2021, with ~75% of such incidents classified as Cumulative Micro-traumatic injuries (i.e., overuse).

“

Barf: “It looks like the Temple of Doom.”

Dot Matrix: “Well it sure ain’t Temple Beth Israel.”

”

Space Balls

**For perspective on potential cost savings derived from employing a humanoid vs. a human laborer, we performed a payback analysis in which we calculated the difference between the cumulative cost of a human laborer vs. the cumulative cost of a humanoid over time.** We used BLS data to ascertain the average median wage for each of the 21 BLS industries with adoptable occupations. Applying this as the implied annual cost for a human worker, we calculated the cumulative cost of employing a human worker over a 20-year time frame from 2030 through 2050. Separately, assuming an average cost per humanoid of \$50,000 and a 10-year useful life, we calculated the cumulative cost of employing a humanoid over the same 20-year time frame.

**Using this payback analysis, we estimate cost savings of ~\$500 thousand to \$1 million+ per human worker over a 20-year time frame.** Below, we include our complete analysis solving for implied cost savings for each BLS industry. We also show implied costs savings in charts for 1) Food Preparation and Serving Related and 2) Transportation and Material Moving, the top "humanoidable" sectors (according to total number of potential adoptions).

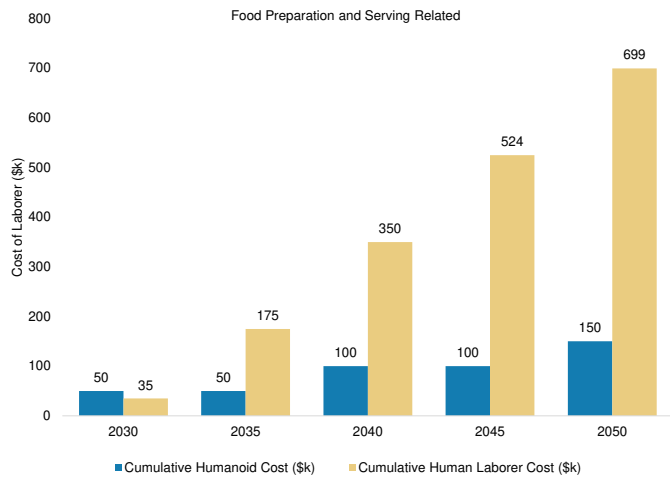
**Exhibit 47:** Payback Analysis: Implied Cost Savings from Employing a Humanoid vs. a Human for All BLS Industries (2030-80)

#	Industry	Human Annual Wage (\$k)	Humanoid Cost (\$k)	Cumulative Humoid Cost - Cumulative Human Cost, \$k				
				2030	2035	2040	2045	2050
1	Food Preparation and Serving Related	35	50	-15	125	250	424	549
2	Transportation and Material Moving	58	50	8	240	480	770	1,009
3	Production	47	50	-3	186	371	607	792
4	Sales and Related	55	50	5	225	450	725	950
5	Healthcare Support	43	50	-7	166	332	548	714
6	Office and Administrative Support	46	50	-4	178	356	584	762
7	Construction and Extraction	54	50	4	219	438	706	925
8	Installation, Maintenance, and Repair	56	50	6	232	464	746	978
9	Healthcare Practitioners and Technical	98	50	48	441	881	1,372	1,812
10	Building and Grounds Cleaning and Maintenance	43	50	-7	164	328	542	706
11	Educational Instruction and Libraries	75	50	25	323	646	1,018	1,341
12	Protective Service	57	50	7	236	471	757	992
13	Personal Care and Service	38	50	-12	142	285	477	620
14	Management	109	50	59	497	993	1,540	2,036
15	Architecture and Engineering	89	50	39	393	785	1,228	1,621
16	Business and Financial Operations	76	50	26	330	659	1,039	1,368
17	Life, Physical, and Social Science	84	50	34	368	736	1,155	1,523
18	Farming, Fishing, and Forestry	44	50	-6	169	339	558	728
19	Arts, Design, Entertainment, Sports, and Media	63	50	13	263	526	839	1,101
20	Community and Social Service	54	50	4	218	436	704	923
21	Legal	90	50	40	398	796	1,244	1,643
22	Computer and Mathematical	104	50	54	471	941	1,462	1,932

Source: Bureau of Labor Statistics, Morgan Stanley Research

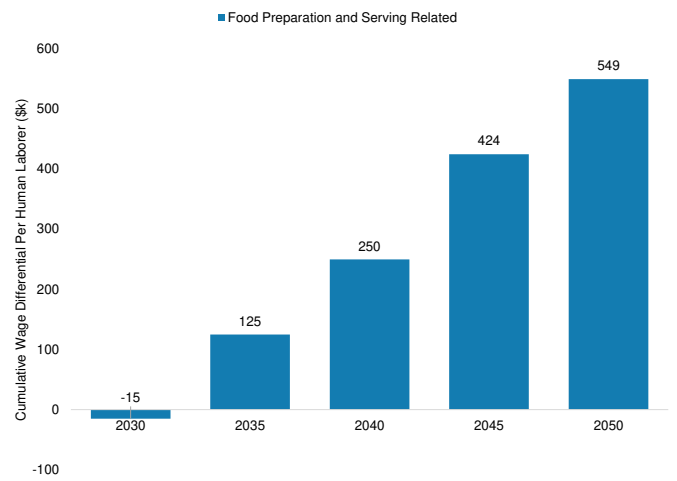
Note: For the purpose of this analysis, we assume an average cost per humanoid of \$50,000 and a 10-year useful life.

**Exhibit 48:** Cumulative Humanoid Cost vs. Human Laborer Cost, Food Preparation and Serving Related Worker (2030-50)



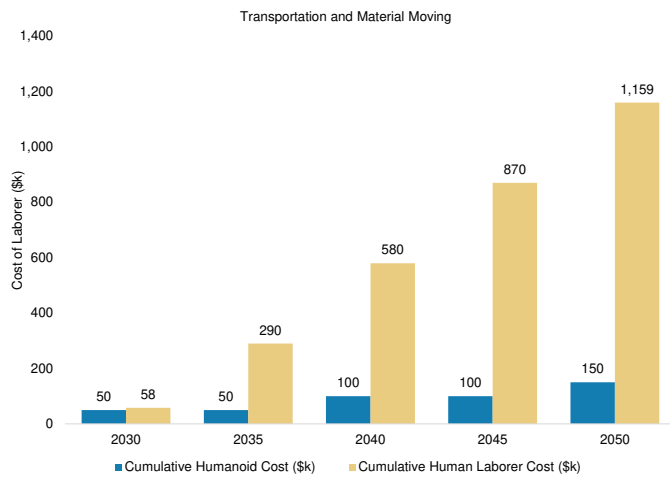
Source: Bureau of Labor Statistics, Morgan Stanley Research

**Exhibit 49:** Cumulative Cost Savings, Food Preparation and Serving Related Worker (2030-50)



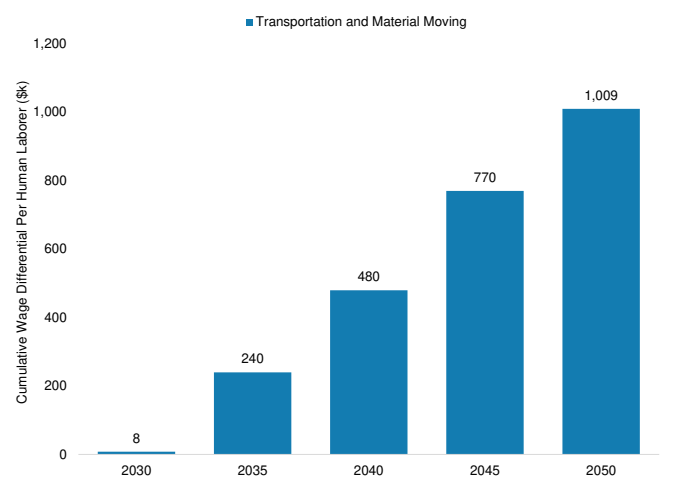
Source: Bureau of Labor Statistics, Morgan Stanley Research

**Exhibit 50:** Cumulative Humanoid Cost vs. Human Laborer Cost, Transportation and Material Moving Worker (2030-50)



Source: Bureau of Labor Statistics, Morgan Stanley Research

**Exhibit 51:** Cumulative Cost Savings, Transportation and Material Moving Worker (2030-50)



Source: Bureau of Labor Statistics, Morgan Stanley Research



**For the purpose of this analysis, please note:**

- We assume a single humanoid is as productive as a human laborer (i.e., this analysis does *not* consider the possibility that a single humanoid could be more productive or less productive than a single human laborer).
- Given we do not have much foresight into the pricing of humanoids or how it may evolve over time, for simplicity we assume *no change* in the cost of a humanoid over time (i.e., we assume the cost of a humanoid is constant from 2030 through 2080). To balance this, we assume *no change* in the cost of labor over time (i.e., we assume wages are constant from 2030 through 2080).
- For simplicity, we also assume the only cost involved in employing a humanoid is the purchase price (i.e., we assume there are no maintenance fees associated with operating a humanoid).

For the payback analysis, we also calculate potential savings outcomes in a bear case, in which we assume a humanoid cost of \$100,000 and a useful life of five years, as well as a bull case, in which we assume a cost of \$25,000 and a useful life of 20 years. *To view the payback outputs for these cases, please see the "Payback Analysis" page of our TAM model. Please also see [Appendix V: Payback Analysis Excel Backup](#) for a snapshot of the full Excel payback analysis.*

## Morgan Stanley Proprietary Humanoid Sector Survey

**Our global collaborative team distills the relative positioning of industries within the robotics value chain and humanoid adoption implications.** Each industry's covering analyst ranked their sector's exposure to humanoid adoption based on seven survey questions. Our survey was conducted in May and June of 2024. Below we summarize the results from 40 sectors.

The sectors we considered to be best positioned for humanoid adoption had the following labor characteristics:

1. Labor is a large element of the industry (labor intensity),
2. Labor faces a challenge (labor shortage, wage inflation, dangerous tasks, etc.), and
3. Labor involves a fairly straightforward task (automation "low hanging fruit")

### Survey Questions:

1. *In your sector, is physical labor required to produce products? How important is physical labor to your sector? (1-4)*
2. *If jobs in your sector require physical labor, would you describe the labor as boring, repetitive, and/or dangerous? (1-4)*
3. *Is there a labor shortage in your sector? How would you describe it — is it getting better or worse? (1-4)*
4. *How often do your companies/management address automation of physical labor? (1-4)*
5. *Would your sector be a beneficiary or would it be challenged if physical labor could be automated? (1-5)*
6. *In your sector, are the below physical demands required of your workers? Please indicate the physical demands that are required. (A - Standing / Walking / Climbing, B - Moving/ sorting items, C - Operating tools, D - Fine motor skills, E - Expressing/communication, F - Other).*

**Exhibit 52:** Survey Results: Quartiles of Humanoid Exposure Across 40 Sectors

**Questions Key:**

- 1) In your sector, is physical labor required to produce products? How important is physical labor to your sector? (1-4)
- 2) If jobs in your sector require physical labor, would you describe the labor as boring, repetitive, and/or dangerous? (1-4)
- 3) Is there a labor shortage in your sector? How would you describe it - is it getting better or worse? (1-4)
- 4) How often do your companies/management address automation of physical labor? (1-4)
- 5) Would your sector be a beneficiary or would it be challenged if physical labor could be automated? (1-5)
- 6) In your sector, are the below physical demands required of your workers? Please indicate the physical demands that are required. (A,B,C,D,E,F)

**Survey responses for Questions 1-6, for each sector:**

Rank	Sector	Question						Total	
		1	2	3	4	5	6		
1	Transportation - Freight and Airlines	4	4	4	2	5	A,B,C,D,E,F	19	1st Quartile
2	Autos & Shared Mobility	4	4	2	4	5	A,B,C,D,E	19	
3	Oilfield Services	3	4	3	3	5	A,B,C,D,E,F	18	
4	Restaurants	4	3	3	3	5	A,B,C,D,E	18	
5	Hardlines, Broadlines and Food Retail	3	4	3	3	5	A,B,D,E	18	
6	Aerospace & Defense	3	4	3	3	4	A,B,C,D,E	17	
7	Softlines Retail & Brands	4	4	3	2	4	A,B,C,D,E	17	
8	Machinery	3	3	2	3	5	A,B,C,D,E	16	
9	Business Services	3	3	2	3	5	A,B,C,D,E,F	16	
10	Clean Tech	4	3	2	2	4	A,B,C,D,E	15	
11	Internet - E-commerce/Gig Economy	4	2	2	3	4	A,B,D,E,F	15	2nd Quartile
12	E&P and Integrated Energy	3	3	2	3	4	A,B,C,E	15	
13	Chemicals	2	4	1	3	4	A,C	14	
14	Healthcare Technology	2	3	2	3	4	E	14	
15	Leisure Product and Service	3	3	2	2	4	A,B,C,D,E	14	
16	Healthcare REITs and Commercial Real Estate	3	3	3	1	4	A,D,E	14	
17	Life Science Tools & Diagnostic	2	2	3	3	4	A,B,C,D,E	14	
18	Power & Utilities	2	2	3	2	4	A,B,C,D,E	13	
19	Refining & Marketing	3	3	1	2	4	A,B,C,D,E,F	13	
20	Semiconductors	2	3	3	2	3	C,F	13	
21	Household Products, Beverages, and Food	2	3	2	2	4	B	13	3rd Quartile
22	Gaming, Lodging & Leisure	2	3	2	2	4	A,B,E	13	
23	IT Hardware	2	2	2	2	4	A,B,C,E	12	
24	Medical Technology & Services	2	2	2	2	4	A,B,D,E	12	
25	Cable & Satellite	2	2	2	1	4	A,B,C,D,E	11	
26	Life and Property & Casualty Insurance	2	4	1	1	3	E	11	
27	Healthcare Technology & Distribution and Managed Care & Facilities	2	1	2	2	4	F	11	
28	Pharma and Biotech	2	2	2	2	3	A,B,C,D,E,F	11	
29	SMid-Cap Biotechnology	2	2	2	2	3	A,B,C,D,E,F	11	
30	Telecom & Networking Equipment, Communication Software	2	1	2	1	4	A,B,C,D,E	10	
31	Telecom Services and Communications Infrastructure	2	2	1	1	4	A,B,C	10	4th Quartile
32	Biotechnology	2	2	1	2	3	A,B,C,D,E,F	10	
33	SMid-Cap Biotechnology	2	2	2	2	3	A,B,C,D,E,F	11	
34	Media & Entertainment	1	1	1	1	4	E	8	
35	Software	1	N/A	3	N/A	N/A	N/A	4	
36	Fintech and Payments	2	N/A	1	N/A	N/A	N/A	3	
37	Internet - Online Ads/Online Travel	1	N/A	1	N/A	N/A	N/A	2	
38	Large Cap Banks	1	N/A	1	N/A	N/A	N/A	2	
39	Midcap Banks	1	N/A	1	N/A	N/A	N/A	2	
40	Brokers, Asset Managers & Exchanges	1	N/A	1	N/A	N/A	N/A	2	

Source: Morgan Stanley Research

(1) Question 6, which identifies physical tasks demanded by each sector, is not considered in the ranking methodology as the responses are non-numerical.

(2) For responses, 1 generally denotes less likelihood for a humanoid substitution case (ie. Low physical labor, no labor shortage, etc.), while 4 or 5 denote higher likelihood.

**Summary of Survey Results**

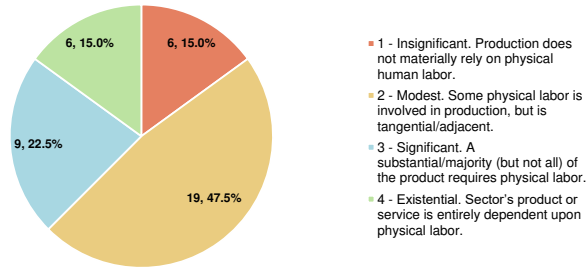
- **Physical labor:** At least modest importance to **85%** of sectors (34 sectors); significant or existential to **38%** of sectors (15 sectors)
- **Boring/repetitive/dangerous physical labor:** **78%** of sectors (31 sectors) have some amount of it; **50%** (20 sectors) think it could reasonably or significantly drive turnover
- **Labor shortage:** At least a modest issue in **70%** of sectors (28 sectors)

• **Physical tasks required:**

- **Moving/sorting items:** **66%** of sectors (27 sectors)
- **Operating tools/machines:** **61%** of sectors (25 sectors)
- **Fine motor skills:** **56%** of sectors (23 sectors)
- **Automating physical labor:** Discussed by management often or extremely often in **30%** of sectors (12 sectors)
- **Beneficiaries of physical labor automation:** **70%** of sectors (28 sectors) would be modest or significant beneficiaries

**Exhibit 53:** 1) In your sector, is physical labor required to produce products/deliver services? (1-4)

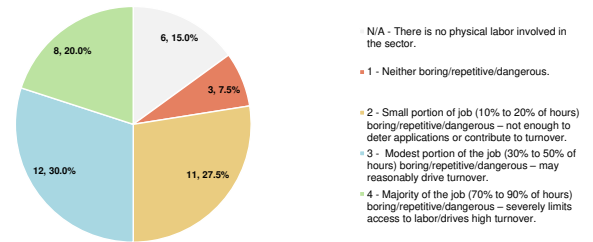
1) In your sector, is physical labor required to produce products/deliver services? (1-4)



Source: Morgan Stanley Research. Includes survey responses from 41 sector teams.

**Exhibit 54:** 2) If there is physical labor, would you describe it as boring, repetitive or dangerous? (1-4)

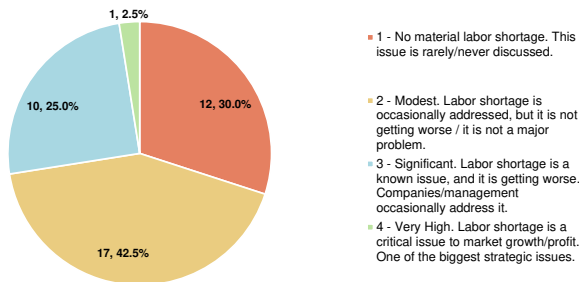
2) If there is physical labor, would you describe it as boring, repetitive or dangerous? (1-4)



Source: Morgan Stanley Research. Includes survey responses from 41 sector teams.

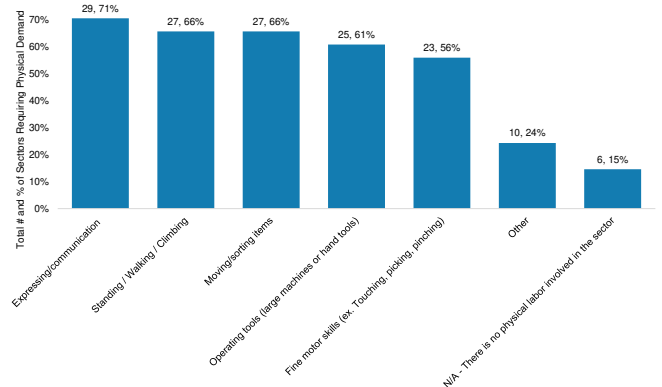
**Exhibit 55:** 3) Is there a labor shortage in your sector? Is it getting better or worse? (1-4)

3) Is there a labor shortage in your sector? Is it getting better or worse? (1-4)



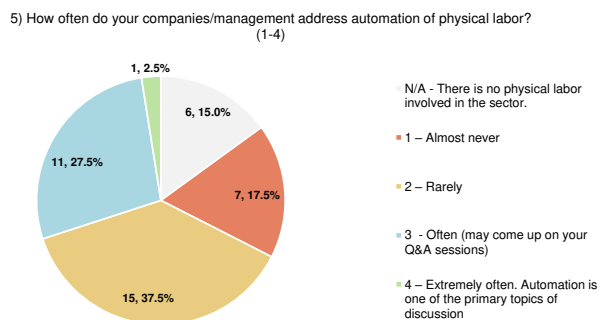
Source: Morgan Stanley Research. Includes survey responses from 41 sector teams.

**Exhibit 56:** 4) In your sector, are the below physical demands required of your workers? Please indicate the physical demands that are required.



Source: Morgan Stanley Research. Includes survey responses from 41 sector teams.

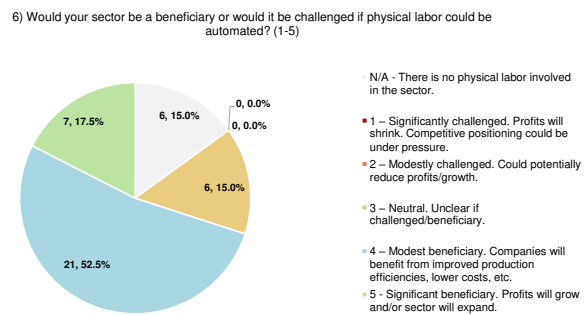
**Exhibit 57:** 5) How often do your companies/management address automation of physical labor? (1-4)



Source: Morgan Stanley Research. Includes survey responses from 41 sector teams.

**Based on survey results, the top four sectors that have the most physical labor, labor shortage, and could benefit most from humanoids include: Autos, Freight Transportation, Oil & Gas, and Restaurants.**

**Exhibit 58:** 6) Would your sector be a beneficiary or would it be challenged if physical labor could be automated? (1-5)



Source: Morgan Stanley Research. Includes survey responses from 41 sector teams.

*For further detail on the sectors that we view as most exposed to humanoid adoption, please see the case studies on Autos, Freight Transportation, Oil & Gas, and Restaurants in our [Sector Adjacencies section](#).*

# Structural Headwinds to US Labor Force

## US Economics

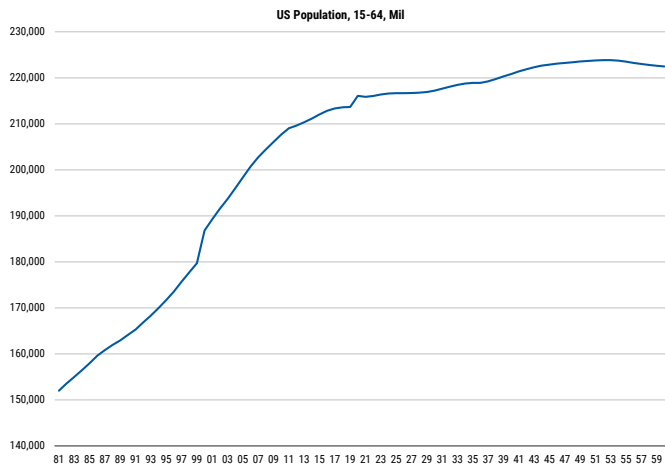
We have analyzed the qualities of specific occupations that position them more for humanoid replacement, but a longer-term theme that will support humanoid adoption is headwinds to labor force growth due to demographics. As growth in the working age population slows, industries that already have difficult attracting workers will face even greater headwinds, forcing them to look toward automation.

“ The reason I'm more excited about humanoid robots than robots of any other shape is that the world is very much designed for humans, and we should absolutely keep it that way. ”

Sam Altman

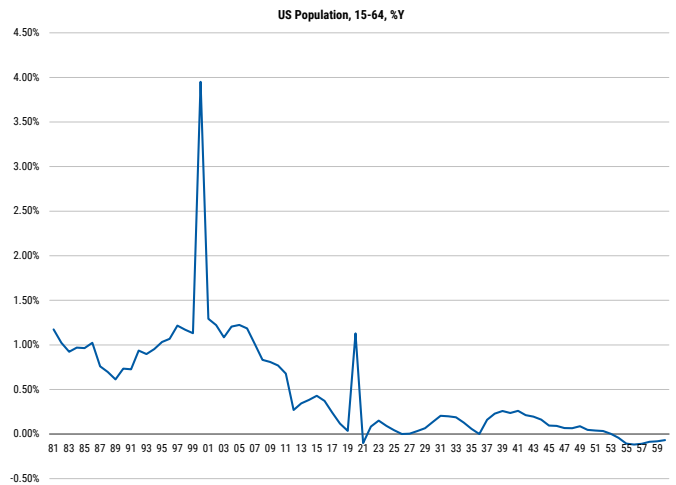
US demographics present a headwind to labor force growth in the US. Growth in working age population (15-64) has been on a downward trend over the past forty years, driven by an aging population, lower fertility rates, and weaker immigration, and is expected to continue to weaken, before beginning to contract by 2050. For context, the working-age population grew by 11.3 million in 2000-05, by 9.3 million in 2006-10, by 4.4 million in 2011-15, and by 4 million in 2011-20. A recent surge in immigration in 2023 and 2024 helps boost near-term working-age population growth, but longer-run headwinds still persist. Without immigration, working age population growth would be even weaker.

**Exhibit 59:** Work Age Population Is Beginning to Plateau



Source: Census Bureau, Morgan Stanley Research

**Exhibit 60:** And Growth Is Expected to Slow Further

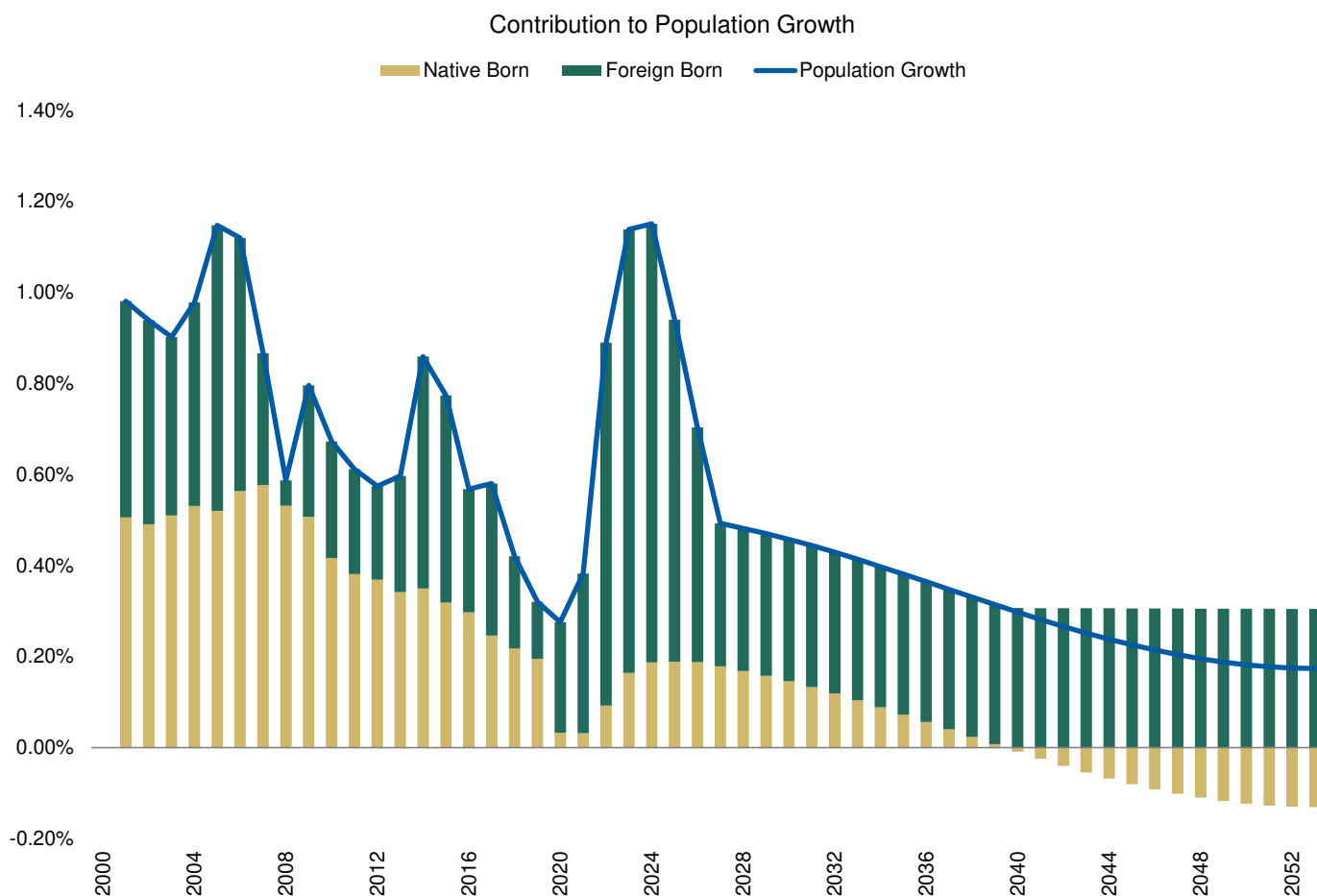


Source: Census Bureau, Morgan Stanley Research



**A recent surge in immigration in 2023 and 2024 is driving population growth higher, lifting labor supply, and putting downward pressure on wages. We do not have confidence this will last (see [US Immigration Policy and Politics](#) ).** It is more likely that immigration flows will slow back toward their pre-Covid pace in the coming decades, at the same time that the growth in then native born population continues to weaken, eventually starting to contract in 2040. Labor supply for the US economy will become increasingly reliant on immigration to support a growing economy, which will be highly uncertain given immigration policy.

**Exhibit 61:** Immigration Plays an Increasingly Large Role in Driving Population Growth



Source: CBO, Morgan Stanley Research

For more details, see [Economic and Labor Considerations](#) .

# Anatomy of a Humanoid: Mapping the Supply Chain

**This section utilizes the insights of our China Industrials Team (Sheng Zhong), Japan Industrials Team (Lisa Jiang), and China Autos Team (Shelley Wang) to map the dynamics and key players within the humanoid supply chain.**

*We would be remiss in not highlighting the Multipolar dynamics at the crux of the humanoid conversation, particularly given the potential magnitude of the humanoid TAM in the labor market and its current heavy reliance on a Chinese industrial supply chain. As we published in our 2023 [BluePaper](#), the US and China are racing to reduce their economic interdependency in crucial sectors. The US is pursuing friend-shoring of critical minerals and the renewable supply chain, including EV batteries, while China works to localise its advanced semiconductor industry and reduce trading partners' dependence on the USD payments infrastructure. For an in-depth discussion, see [Thematics: Practical Guide to a Multipolar World](#).*

## What Goes into a Humanoid Robot?

Sheng Zhong

**As the embodiment of AI, humanoid robots are designed to think and act like humans.** AI enables robotic "brain function," underpinning the robot's intelligence level, and the range of potential use cases. Mechanical parts enable the body function, underpin manipulation, and the BoM reduction potential. We believe future AI+machinery improvement will decide the pace of humanoid adoption (see [Scenario Framework: Labor Shortage Meets AI](#)).

**The operating system (AI+motion control system) is the most valuable part of a humanoid robot since it underpins the humanoid's intelligence level,** including multimodal perception, logical thinking, and motion control. The AI chip (mostly provided by AI chip players such as NVIDIA, though we note Tesla reuses its autopilot algorithm for Optimus) perceives input information and generates instructions after logical thinking. The motion control system, which receives the instructions from the AI chip, controls the joints to perform commands sent from the AI chip with high precision and stability and also, in return, provides real-time feedback to the AI chip.

**AI algorithms can empower the humanoid's operating system mainly by improving scalability, precision, and stability.** In the long term, OEMs with the leading operating systems could drive both the

direction of humanoid technological advancement and the pace of humanoid mass production. At the current moment, humanoid AI algorithms are still in the beginning stages of development, requiring lots of on-site validations, algorithm iterations, and hardware run-in for perfection. We believe AI algorithms can empower the humanoid operating system by improving its:

- **Scalability:** The humanoid operating system, integrated by humanoid OEMs, is usually specifically designed for a model or series in different scenarios. AI algorithms can improve versatility of the operating system, thus accelerating penetration of humanoid robots in different downstream applications.
- **Precision:** AI algorithms can effectively improve motion control precision with real-time monitoring capabilities, autonomous learning and task optimization, and unsupervised simulation and testing.
- **Stability:** Integrated with a variety of high-precision sensors, AI algorithms can improve the humanoid operating system's stability with processing massive multi-dimensional sensor data, providing more granular data analysis, and indicating potential failures by early identification of anomalies.

**On hardware, actuators are core to performing human-like motions, acting as the robotic-equivalent to human joints/muscles. Over the long term, humanoids will need greater amounts of actuators to facilitate greater degrees-of-freedom.** Hardware plans can significantly vary across different humanoid problems in terms of degrees-of-freedom (DoF), hands design, sensor sensitivity, etc. *We include an overview of notable "humanoid hardware" below:*

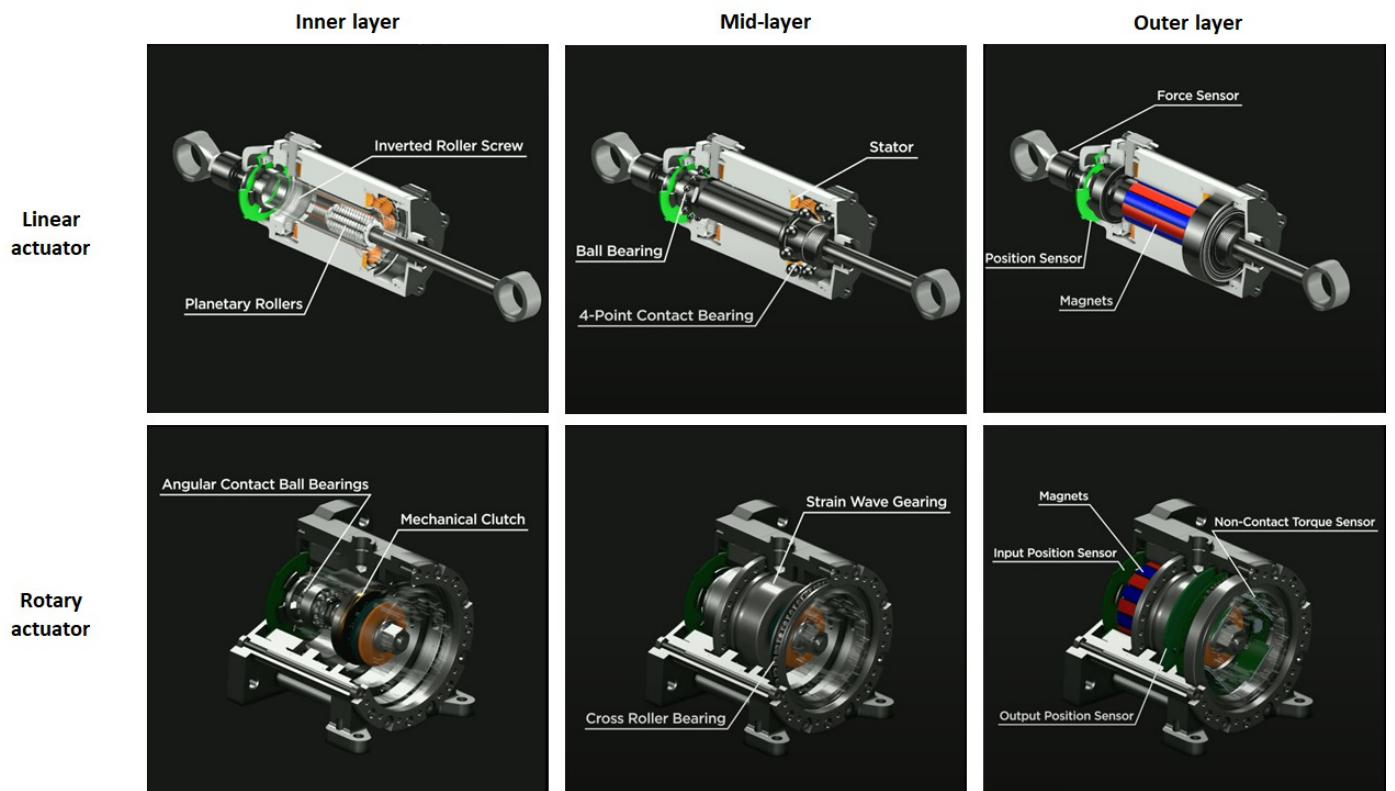
- The **"bot brain,"** or central computer, is a system-on-chip (SoC) that processes the wide array of inputs and outputs used to drive all the hardware used on the robot (cameras, WiFi module, audio, etc.). For Tesla, the design for the bot brain is largely derived from Tesla FSD hardware and software.
- The **humanoid body** is mainly composed of actuators and supporting systems (battery pack, structural parts, thermal system, etc.).
  - **Actuators** are devices that enable motion in a system, both rotational or linear (similar to human joints). The greater the degrees-of-freedom required, the more

actuators that are needed. Currently, humanoids in development generally are capable of between 16 and 60 DoF. Optimus, in particular, uses 50 DoF, driven by 28 actuators (14 linear, 14 rotary). The actuators themselves are comprised of a combination of screws, reducers, motors, sensors, ball bearings, and encoders.

- **Structural parts** are supporting material around the humanoid body, such as the skeleton and outer shell.

The Optimus Gen2 loses 10kg without sacrificing its structure and performance, primarily from the use of lightweight material such as PEEK (Polyether Ether Ketone) and high power density actuators. PEEK is a synthetic material often used as a metal substitute due to its excellent strength and light weight, which helps to reduce overall energy consumption while preserving performance.

**Exhibit 62:** Linear and rotary actuators are comprised of screws, reducers, motors, sensors, bearings and encoders (shown below are Tesla Optimus actuator designs).






Source: Tesla 2022 AI Day, Morgan Stanley Research

Exhibit 63: Overview of Key Parts Used in a Humanoid Robot

Key Parts		Overview	
<b>Brain</b>			
<b>AI Chip and Software</b>	The bot brain is based on an AI chip with additional inputs and outputs for telecommunication, audio, security and safety.		
<b>Body Parts</b>			
<b>Linear or Rotary Actuator</b>	<b>Screw</b>	A screw is a mechanical component that converts motor-end rotary motion into linear motion. Considering cost and technology maturity, current humanoids are more suitable for using both ball screws and planetary roller screws but should, over time, fully shift to planetary roller screws with technology breakthrough and cost reduction.	<p>Ball screw      Roller screw</p>
	<b>Reducer</b>	A reducer is used for reducing motor speed and improving the torque output and motion accuracy of humanoid's joints. Humanoids mainly use harmonic and planetary reducers, but RV reducers could be an alternative.	<p>Planetary Reducer      Harmonic Reducer</p> <p>RV Reducer</p>
	<b>Motor</b>	A motor is used to generate driving torque, and is installed on the joint of the humanoid to control motion. The higher degrees-of-freedom, the more motors used. Tesla's Optimus mainly applies frameless torque motors for body parts and coreless motors for hands.	<p>Frameless torque motor      Coreless motor</p>
	<b>Sensor</b>	Humanoids require sensors to sense the surrounding environment and objects. Commonly used sensors are vision sensors, force sensors, inertial sensors, temperature sensors, etc. The core sensor of a humanoid is the force sensor, which converts the magnitude of the force into a relevant electrical signal.	<p>6-Axis Force Sensor      Torque Sensor</p>
	<b>Bearing</b>	A bearing is a supporting part for mechanical rotary motion. It ensures rotary precision by primarily supporting the mechanical rotary, and serving to fix and reduce friction to ensure the accuracy of the rotary.	<p>Bearing</p>
	<b>Encoder</b>	Encoders are connected to the motor to monitor its status and send the signal back to the actuator, which aggregates, analyzes, and corrects the feedback signal to precisely control output variables such as actuator position, speed, and torque.	<p>Encoder</p>
	<b>Structural Parts</b>	Structural parts are mainly made from PEEK (Polyether Ether Ketone), a lightweight material to reduce energy consumption. PEEK is a specialty polymeric material with excellent properties such as heat resistance, abrasion resistance and radiation resistance. PEEK has gradually replaced the use of metal materials in mid-to-high end robotics due to its excellent performance.	

Source: Morgan Stanley Research

**Exhibit 64:** Humanoid motion can be driven by electric, hydraulic or pneumatic drive system, but electric driven humanoid design is currently mainstream with higher precision and faster reaction.

Drive type	Introduction	Applicable scenarios	Key components	Pros	Cons	Key players	
<b>Electric drive</b>	The motor drives the humanoid's joint rotation or other motions		Mature and widely used	DC/AC servo motor, stepping motor, electromagnet	Highly controlled precision, fast response speed, reliable and able to achieve complex movement and motion	High power consumption, weight limitations, large space requirement, need to prevent problems such as overheating and overloading	For most humanoid companies
<b>Hydraulic drive</b>	To produce high pressure liquid through liquid compression pump, and then works on the output mechanism to generate force		Apply to large-size, heavy loads and humanoids for emergency or speciality use	Reciprocating oil cylinder, hydraulic motor	Higher torque, fast motion, high stability, and able to achieve large loads and complex motion	Complex design and high maintenance requirement	BostonDynamics
<b>Pneumatic drive</b>	Use pneumatic actuators to convert the pressure of compressed air into mechanical energy to drive joint and limb movement		Suitable for mid-to-small loads humanoids	Reciprocating oil cylinder, hydraulic motor	Clean, zero pollution, easy to operate, low cost and easy to maintain	Limited torque and stability, unable to achieve large loads and complex movements	FESTO

Source: Morgan Stanley Research

**Exhibit 65:** Hardware Design of Selected Humanoid Models

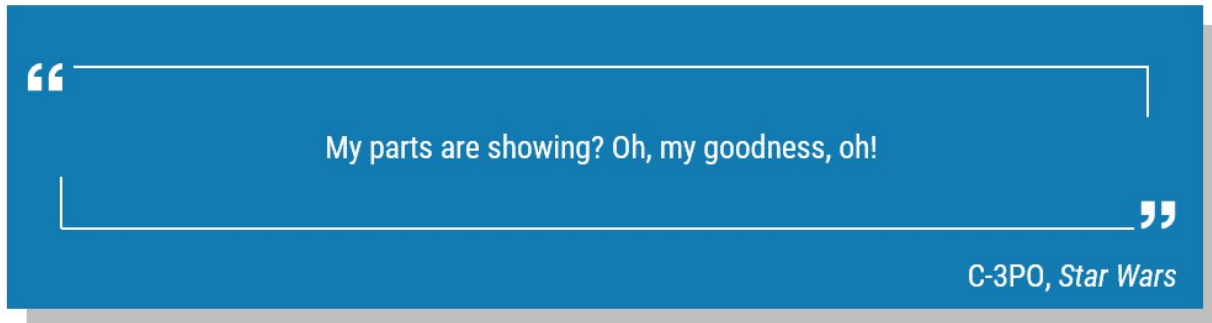
Hardware Design for Selected Humanoid Models									
Region	Company	Humanoid Model	Degrees-of-Freedom	Actuator Type	Core Part Type				Human-like Hands
					Reducer	Motor	Force Sensor	Encoder per Actuator	
USA	Tesla	Optimus	50	Rotary + Linear	Harmonic Reducer + Planetary Roller Screw	Frameless Torque Motor	Equipped	2 Per Rotary Actuator + 1 Per Linear Actuator	Coreless Motor + Precise Planetary Gearbox
USA	Agility Robotics	Digit	16	Unspecified	Harmonic Reducer / Cycloidal-Pin Gear Speed Reducer	Brush/Brushless DC Motor	Unspecified	Unspecified	Unspecified
Norway	1X Technologies	EVE	25	Unspecified	Unspecified	DD motor	Unspecified	Unspecified	No Hands
China	UBTech	Walker X	41	Rotary	Harmonic Reducer	Frameless Torque Motor	Equipped	2	Unspecified
China	Unitree	G-1	20-43	Rotary	Planetary Reducer	Frameless Torque Motor	Unspecified	2	Coreless Motor + Planetary Reducer
China	Xiaomi	CyberOne	21	Rotary	Planetary Reducer	Frameless Torque Motor	Not Equipped	1	Unspecified
China	XPeng	PX5	Unspecified	Unspecified	Harmonic Reducer + Planetary Reducer	Unspecified	Unspecified	Equipped	Coreless Motor + Connecting Rod

Note: Hardware design of other key humanoid models such as Figure 01 from Figure A1, Phoenix from Sanctuary AI, Atlas from Boston Dynamics is not public.

Source: Company data, Morgans Stanley Research

## Assessing the Humanoid Bill-of-Materials

Sheng Zhong



**There is a wide range of potential BoM costs for humanoids, largely depending on design complexity, material, and market positioning.** Under our estimates, building humanoid robots could range from \$10k to \$300k given different configuration and downstream application requirements. For instance, China's Unitree announced its G-1 humanoid robot priced at ~\$16k on May 2024, with a simplified algorithm module, halved degrees-of-freedom, shorter battery life, and lower carrying capacity. In contrast, with an estimated selling price at \$250k in 2025, Agility Robotics's Digit is specifically designed for logistics, featuring high power capacity and payload, high man-machine interaction intelligence, and a high degree of balance/stability.

**Using Tesla's Optimus Gen2 as an example, we estimate the current total ex-software BoM at \$50-60k per unit, using price quotes from various component suppliers.** However, we note this is using quoted prices for individual components used to create the robot. For a player building humanoids at scale, such as Tesla, the BoM could likely be significantly lower given various relationship, bundling, and/or bulk discounts with the various component suppliers. In our view, Tesla's Optimus has significant opportunity for cost reduction to achieve CEO Elon Musk's targeted selling price of ~\$20k.

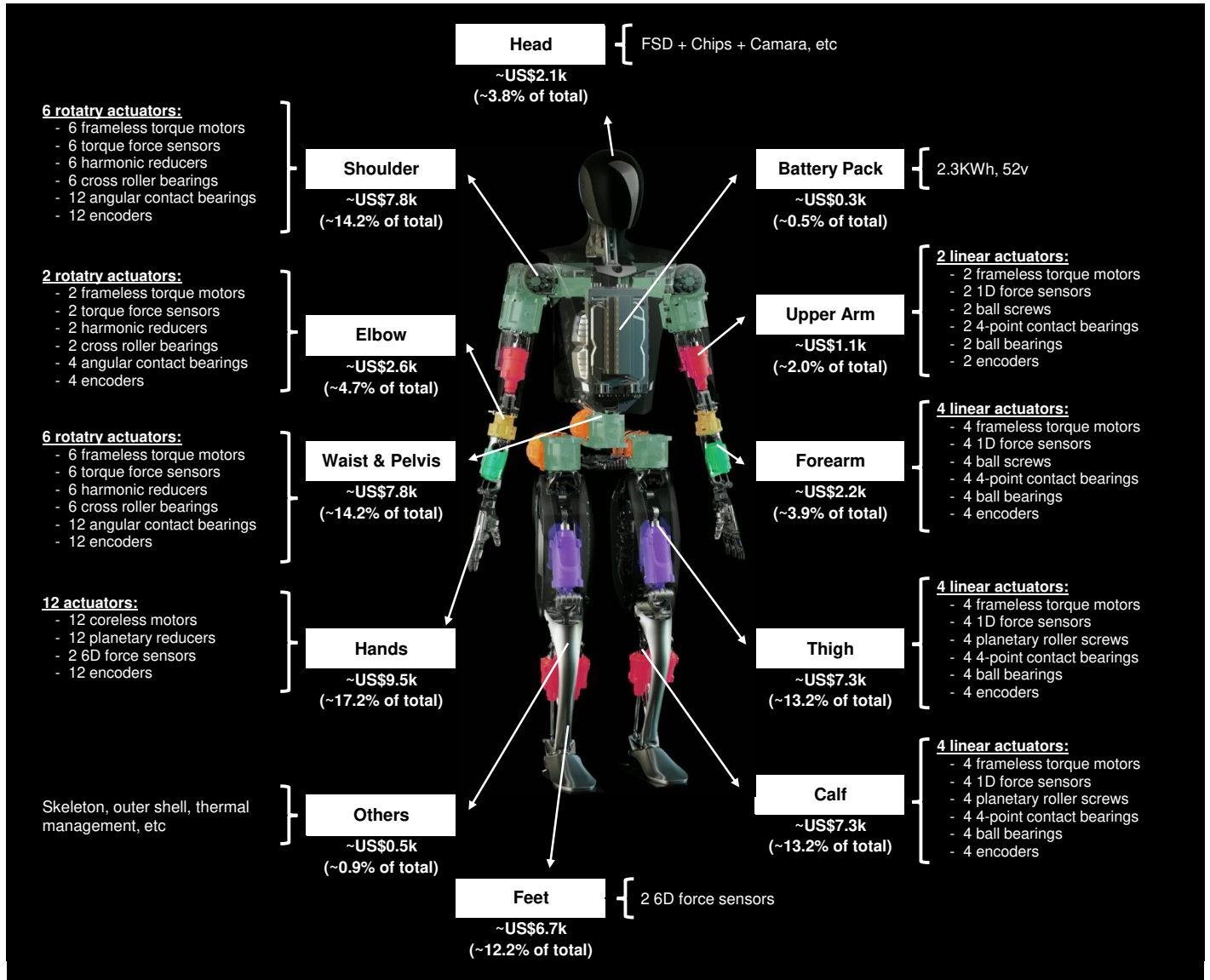
### We breakdown the BoM for Optimus Gen2 by function:

- The "Bot brain" is based on a Tesla SoC and additional outputs and inputs (eg. wifi, camera, audio, etc.). For the "brain" itself, we estimate the hardware cost is ~\$2k/humanoid (~4% of total). Note, this excludes any potential software cost (e.g., FSD training costs).
- All body motion is driven by 28 actuators (14 linear actuators and 14 rotary actuators). The upper body (shoulder, elbow, arm, hands and waist) requires 16 actuators which we estimate could cost ~\$26k/humanoid (~47% of total), and lower body (pelvis, legs, feet) requires 12 actuators which cost ~\$26k/humanoid (~48% of total).
- Other supporting systems including the battery and various structural parts cost ~\$419/humanoid, (~0.8% of total)

When breaking the components down by product type, the key five parts of sensors/screws/motors/reducers/bearings cost ~\$20k/\$11k/\$11k/\$7k/\$434 per humanoid, accounting for ~37%/20%/20%/13%/0.8% of the total BoM.

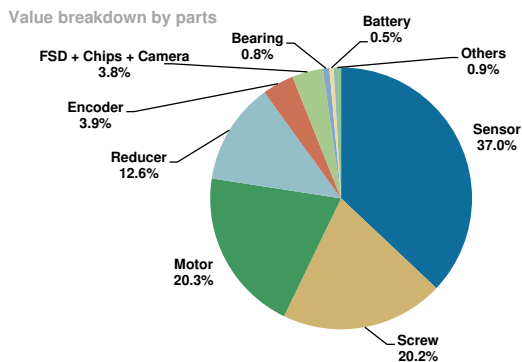


**Exhibit 66:** We estimate current total ex-software BoM for Tesla Optimus at \$50-60k per unit.



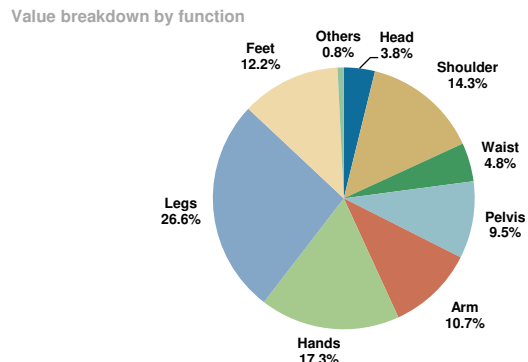
Source: Tesla, Morgan Stanley Research.

**Exhibit 67:** Optimus Gen2 BoM breakdown by parts



Source: Morgan Stanley Research estimates.

**Exhibit 68:** Optimus Gen2 BoM breakdown by function



Source: Morgan Stanley Research estimates.

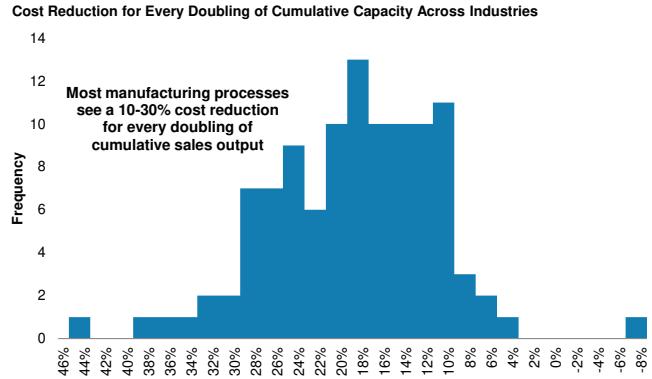
**For most manufacturing processes in a wide range of industries, empirical study shows that cost reduction would be 10-30% for every doubled cumulative sales output in the long term.** The cost reduction curve in the long term can be explained by Wright's Law, which suggests that for every doubled output, the cost of production would fall by a fixed percentage. Based on extensive scholarly papers running learning curve analysis across a wide range of industries, for every doubled cumulative output, most manufacturing process can achieve 10-30% cost reduction over time. For example, for every doubled cumulative sales output, unit costs decreased ~20% for solar modules since the 1970s and have also decreased ~20% for lithium battery since 1990s.

**We think that in the long term, humanoid cost reduction could be in-line with the range of 10-30% for every doubling of cumulative sales output, with potential to exceed expectations, due to the 1) enormous TAM created by human labor replacement; 2) shorter R&D cycle with technology development; and 3) increasing penetration of China's supply chain.**

**1) Very Significant TAM for Humanoid Robots**

**The potential humanoid TAM long-term could be ~\$3 trillion for US alone, with ~3/4 of occupations and ~40% of employees in the US replaceable by humanoid.** Cost reduction of humanoids could be

**Exhibit 69:** Wright's law has been extensively examined in empirical study that most manufacturing processes in a wide range of industries see 10-30% unit cost reduction for every doubled cumulative sales output.



Source: ICEAA, Morgan Stanley Research.

faster than expectations given the large TAM related to replacing human labor in extensive downstream scenarios, potentially driving volumes above expectations. Starting with structured production processes in industrial manufacturing (e.g., auto assembly lines, logistic, and material handling), humanoids will likely gradually penetrate into more complex and unprogrammed environments, tackling both commercial and household tasks.

**Exhibit 70:** Current Humanoid Penetration Across Major Use Cases

Current Humanoid Penetration		
Industrial Applications	Commercial Applications	Service Applications
<p><b>Scenarios:</b> assembly line, testing, maintenance</p> <p><b>Technology:</b> machine vision, multimodel perception, high-precision and high-stability motion control</p>	<p><b>Scenarios:</b> education, public services, entertainment</p> <p><b>Technology:</b> high versatility with portable codes, high-strength materials</p>	<p><b>Scenarios:</b> elderly service, health care services, security and safety</p> <p><b>Technology:</b> emotion analysis, high-level of man-machine interaction, high-precision sensor</p>

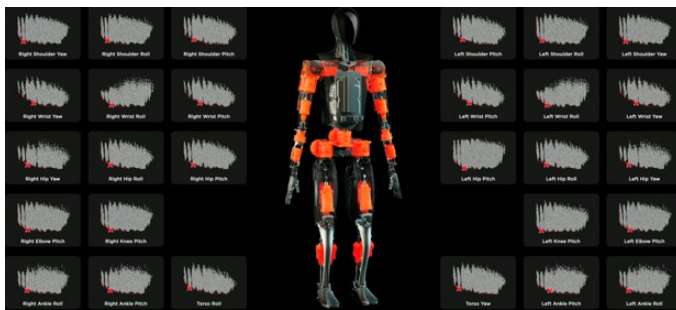


Source: Morgan Stanley Research

## 2) Faster Technology Iteration as AI Evolves

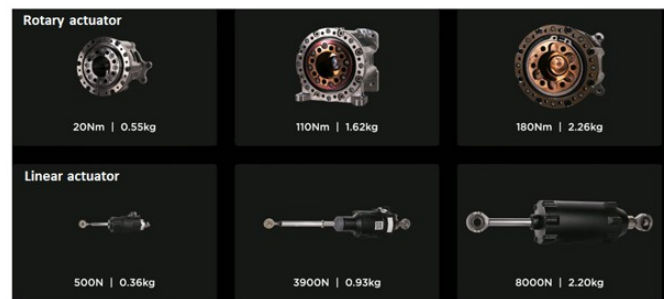
AI algorithms can significantly shorten the R&D cycle by automating repetitive tasks, enhancing data analysis and predictive capabilities, enabling virtual simulation and optimizing design and testing processes. Using Tesla as an example, the company created their own in-house actuators for Optimus from scratch. At the beginning, Tesla put forward thousands of unique actuator designs for each 28 regular human-line motions. Through use of simulation models, Tesla was able to map out the cost curves of all possible designs to find the most optimized actuator design for each of the 28 motions, prioritizing unit costs and mass per design. ("X" represents the most optimized actuator design for each motion. Exhibit 71) To maximize simplicity and cost, Tesla applied commonality analysis to narrow the 28 unique designs to just 3 linear and 3 rotary actuators, enabling greater scalability and cost efficiency.

**Exhibit 71:** Optimus adopts 28 actuators (14 linear, 14 rotary) to perform 28 regular human movement activities. The "x" denotes the most optimized design with lowest unit cost and mass, among >1k designs for each movement.



Source: Tesla 2022 AI Day, Morgan Stanley Research

**Exhibit 72:** By identifying commonalities among the 28 primary human movements, Tesla minimized the range of actuators used for Optimus to just 3 linear and 3 rotary actuators.



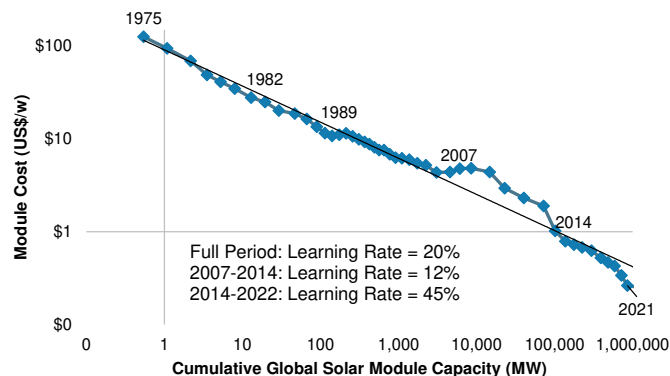
Source: Tesla 2022 AI Day, Morgan Stanley Research

## 3) Cost Reduction Could Accelerate with Rising Penetration of the Chinese Industrial Supply Chain

The completeness and scale of China's industrial supply chain provides significant advantages related to potential cost reduction. We believe investors should consider the solar supply chain as a case study for the potential benefits of utilizing the Chinese supply chain in humanoid production. Between 1975 and 2022, solar modules saw a ~20% price decline, on average, for each doubling in cumulative sales output. However, as players in the industry increased their utilization of the Chinese supply chain, the price decline per doubling in output accelerated to 45% between 2014 and 2022.

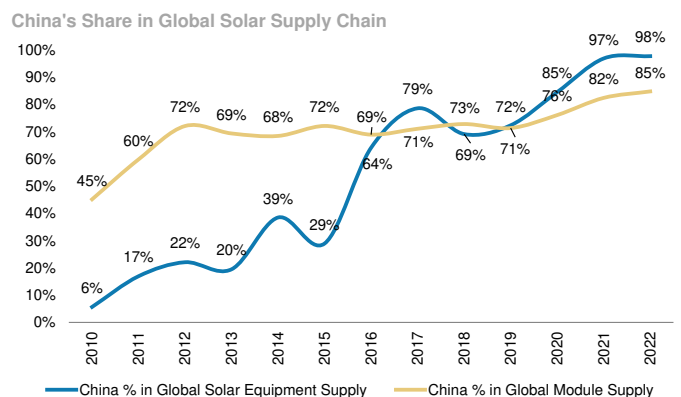
- **Current order book of humanoid parts, ranked by China supply chain exposure:** Motor (~60% for frameless torque motor), Reducers (40-60%) > Sensors (25-30% for torque sensors), Bearings (20%+), Screws (ball screw 40%+, planetary roller screw ~10%, we expect planetary roller screw could replace ball screw in future).

**Exhibit 73:** Solar module prices have declined by ~20% globally for every doubling in output between 1975 and 2022, with the price decline accelerating to ~45% in 2014-22.

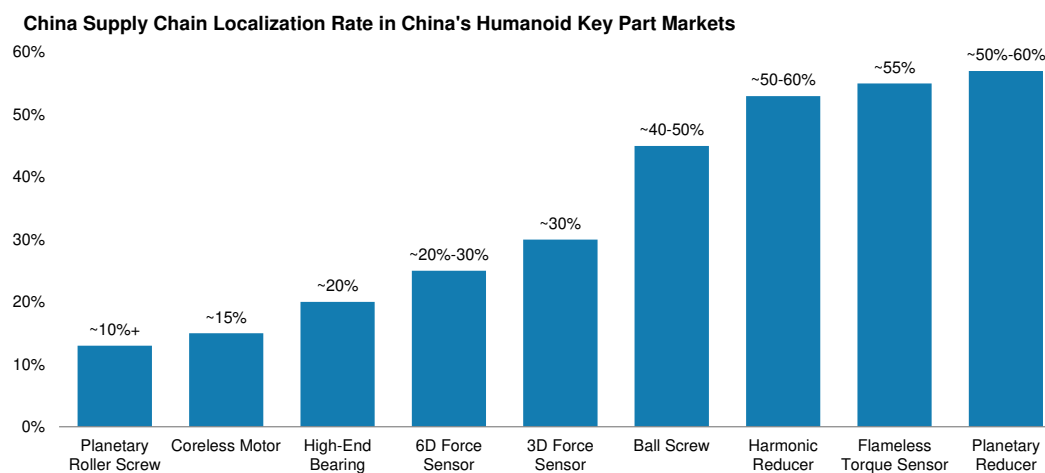


Source: OurWorldinData, Morgan Stanley Research

**Exhibit 74:** At the same time, China has significantly improved their share of the global solar equipment supply chain since 2014-15.



Source: CPIA, Morgan Stanley Research.

**Exhibit 75:** Current China Supply Chain Penetration in the Humanoid Parts Market

Source: M2, Morgan Stanley Research.

## A Worldwide Supply Chain

*Sheng Zhong*

**Screws, motors, reducers and sensors are the key components in machinery manufacturing.** While the high-end component markets are dominated by Europe, US and Japan companies, Chinese companies are competitive in low/midrange products where they aim to provide valuable products. However, there is still a large gap between the low/midrange vs. high-end products in terms of precision, stability, payload, and production process optimization capabilities.

**Screws** components convert rotary motion and linear motion into one another. They are widely used in CNC machine tools, manufacturing equipment, robots, precision instruments, and other downstream applications. Humanoids, such as Tesla Optimus, mainly use ball screws and planetary roller screws for linear actuators to perform high-precision motions. With high barriers to entry and expensive production equipment and raw materials, high-end screw manufacturing is dominated by Europe (Rollvis, SKF, etc.) and Japanese companies (NSK, etc.). Today, there is still a wide gap on efficiency, payload, and precision with Chinese companies and high-end foreign products. However, some Chinese companies (Hengli, Best, etc.) have started to penetrate the higher-end market and have proceeded to demo validation for humanoid OEM companies.

**Motors** are used to generate driving torque and are mounted on the humanoid joints to control motion. On humanoids, frameless torque motors are widely used for both linear and rotary actuators to facili-

tate manipulation due to their small size, compact structure, light weight, small rotating inertia, and low starting voltage. Coreless motors are generally used in human-like hands, featuring higher energy-saving, low voice, high useful life, and high torque.

- *Frameless torque motors have a relatively low technology barrier.* Germany's Kollmorgen dominates in high-end frameless torque motor for high-end applications, while Chinese products are widely used for other low/midrange applications. Kinco (not covered) is the leading Chinese supplier and one of few that can provide high-quality frameless torque motors.
- *On the other hand, coreless motors have a much higher technology barrier,* with concentrated applications in medical and military equipment. Currently, foreign suppliers account for >85% market share in China. Chinese companies entered the market in the 2010s, but there is still a large performance gap between domestic and imported products on no-load speed and rated torque. However, we note that for coreless motors used on humanoid hands, companies like Moon's have already penetrated the humanoid supply chain and are running demo validation for OEMs.

**Reducers** are used both for reducing motor speed and for improving the torque output and motion accuracy of humanoid joints. Planetary reducers, harmonic reducers, and RV reducers are the

three primary categories of reducers. Different humanoid design require different type/quantity of reducers. All three of these primary reducer categories are dominated by Japanese companies (Harmonic Drive, Shimpo, subsidiary of Nidec, Nabtesco, etc.). Today, Chinese companies still have a large performance disadvantage on both precision and stability, but we note that leading Chinese players, such as Leaderdrive, have sent harmonic reducers for demo humanoids.
















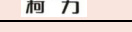
















**Sensors**, including vision sensors, force sensors, inertial sensors, temperature sensors, etc., are the essential hardware for humanoid's multimodal perception both internally (perception of its own posi-

tion) and externally (perception of touch, vision, hearing, etc.). Force sensors are more vital sensors for humanoids to achieve smooth and real-time force adjustments under various scenarios. Six-axis force sensors, the most complex force sensors, can measure payloads from any direction and bear payloads 5-20x higher than rated measurement ranges. ATI (a US company), the inventor of the six-axis force sensor, dominates this market, while most Chinese companies still lag without long-term accumulation in sensor calibration and decoupling. Other first movers such as Kunwei and SRI have begun to penetrate the sensor supply chain for humanoids.

## Key Investable Players in the Humanoid Supply Chain

Sheng Zhong, Lisa Jiang, & Shelley Wang

Exhibit 76: Major Global Players in the Humanoid Supply Chain

Major Global Players in the Humanoid Supply Chain											
Screws	Swiss		Rollvis	Private	Motors	Frameless Torque Motors	Germany		Kollmorgen	Private	
			GSA	Private			China		Kinco	688160.SS	
	Sweden		SKF	SKFb.ST			Coreless Motors	US		Maxon	Private
	Japan		NSK	6471.T				China		Moon's	603728.SS
	China		Hengli	601100.SS		Sensors	Force Sensors	US		ATI	NOVT.US
			Best	300580.SZ				China		Kunwei	Private
			Dingzhi	873593.BJ						Keli	603662.SS
			XCC Group	603667.SS						SRI	Private
			Beite Technology	603009.SS				Bearings	US		Timken
	Netherlands		ATB Automation	Private		Japan			NSK	6471.T	
Japan		Harmonic Drive	6324.T		NTN		6472.T				
China		Nidec-Shimpo	Parentco 6454.T	China		XCC Group	603667.SS				
		LeaderDrive	688017.SS	Encoders	Japan		Tamagawa		6838.T		
	Shuanghuan	002472.SZ	Germany			Heiderhain	Private				
China		Tuopu	601689.SS		US		Sensata	ST.US			
Thermal Management	China		Sanhua	002050.SZ	US		Celera Motion	NOVT.US			

Note: Only captures select players within the supply chain. We note many competitors are not listed in this exhibit.

Source: Morgan Stanley Research.



## LeaderDrive (688017.SS, covered by Sheng Zhong)

**Leaderdrive has expertise in harmonic reducer industry over 20 years.** It is now the 2nd largest player globally, with 26% market share in China according to Gaogong Robots, following Japanese player Harmonic Drive. Starting from industrial robots, the company delivered over 200k units harmonic reducers and generated Rmb300mn revenue in 2023, and is aiming to expand to other downstream opportunities like machine tools, with new products introduced like numerical control rotary table, in an attempt to seize a bigger market in the longer term. The company has strong innovation capabilities. For example, it developed a new generation of harmonic drive system-third harmonic reducers, with unique materials and special heat treatment processes, which have a longer life cycle, and are very suitable for application scenarios that require incredibly high transmission accuracy.

**Leaderdrive is a primary beneficiary of the humanoid robotics tailwind.** We note that >10% of the estimated humanoid BoM relates to harmonic reducers, Leaderdrive's specialty. Leaderdrive is also known for their superior product quality with good price-to-value relative to competition. Since last year, it has cooperated with Tesla and sent samples of their product. Despite macro headwinds in the near term and soft industrial robots demand on weaker capex, the long-term potential for the company remains promising amid localization trends.

## Harmonic Drive Systems (6324.T, covered by Lisa Jiang)

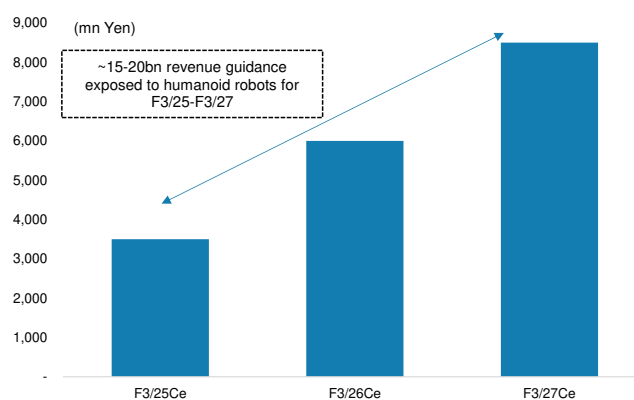
**Prominent market presence.** Harmonic Drive Systems is the leading producer of gear reducers globally, mainly engaging in harmonic gear reducers which are used in small/medium-sized robotics. The company currently has a very high market share in small-sized robotics. It has a near monopoly in the global market ex-China with market share relatively stable over the past few decades. In China, Harmonic Drive Systems primarily competes with local players and Nidec's harmonic gearing subsidiary. Because the selling price of Harmonic Drive Systems' products are at least 20-30% higher than that of rivals due to their relatively higher quality, some customers who purchase reducers for low-end applications focus primarily on cost performance and, as a result, the market share of Harmonic Drive Systems among Chinese local customers (which generally aim to build cost-efficient robots) is not as high relative to other regions. We note it still has a high share among foreign robotics makers in China.

**Humanoid robotics opportunity depends on customer requirements.** More companies are doing R&D in humanoid robots for different applications, with a mix of both high-end and low-end demand. In our view, there is a lower probability that robots used in simple applications would use Harmonic Drive Systems' products (over-spec to perform simple operations). We believe only humanoid robots designed for more complicated applications will utilize reducers from Harmonic.

**What are the possible applications for humanoid robots?** Since Harmonic Drive Systems is just the component supplier for humanoid robots, the company does not have clear visibility into the end applications of its products. However, the company has emphasized in the past that its components could be adopted on robots in more complex/high-end applications (with fairly low applicability to simple applications).

**Harmonic Drive Systems has guided to high revenue potential from humanoid robots.** The company announced its F3/25 guidance and new mid-term plan (F3/25~F3/27) on May 13, expecting humanoid robot-related revenue to be ¥3.0-3.5 billion in F3/25 and ¥15-20 billion for the period covered by the mid-term plan. Harmonic commented that it is witnessing multiple ongoing projects and has gotten more bullish over the past three months. It also has strong confidence in the F3/25 target, but is not denying the risk of missing the midterm plan target due to the low visibility after F3/25.

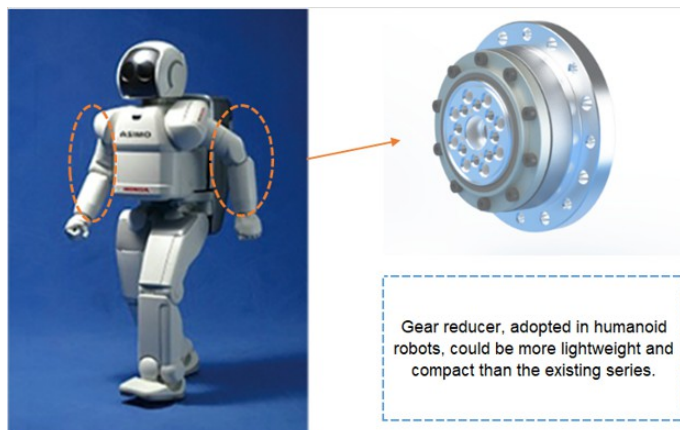
**Exhibit 77:** Harmonic Drive Systems: Guidance Related to Humanoid Robots



Source: Company data, Morgan Stanley Research. Note: the revenue for F3/26 and F3/27 is MS estimates



**Exhibit 78:** Harmonic Drive System: Current Adoption is Primarily for Robot Arms



Source: Morgan Stanley Research

**Current orders are mainly for robot arms.** In humanoid robots, there are several places where there is some possibility to use harmonic gear reducers. However, the company indicated that at present it is mainly seeing projects related to robot arms, similar to industrial robots. So this time the revenue guidance for F3/25 and also for the mid-term plan is just for robot arms. Meanwhile, there is still some potential for further adoption in robot fingers in the future, but the final components adopted in fingers of humanoid robots mostly depend on the end application — harmonic gear reducers are necessary for complicated applications while linear guides or pneumatic components could be adopted for some simple movements.

“

The light that shines twice as bright burns half as long. And you have shined so very, very brightly Roy!

”

Eldon Tyrell, *Blade Runner*

## Potential actuator assemblers for Tesla Optimus

A few Tesla tier-1 suppliers in China mentioned that they have been sending actuator samples to Tesla since 2023, and see the opportunities to enter Tesla Optimus supply chain. Two reasons why we think Tesla EV suppliers can become Tesla Optimus suppliers:

- 1. Know-how in module assembly:** Although Tesla said it will make actuators in-house, we think the 'in-house' mainly refers to software algorithm and product design, while it can outsource hardware manufacturing to tier-1 suppliers, similar to how it works with suppliers on EV. Thanks to Tesla suppliers' experience in EV parts assembly such as thermal management module and domain controller module, these suppliers can apply similar know-how on actuator module assembly.
- 2. Know-how from auto parts:** We think some parts share similar structures on robot and EV, e.g., sending an electric signal to execute precise movements in an electromechanical system. Therefore, suppliers can leverage the knowledge in auto electronics and apply it on robotic parts.

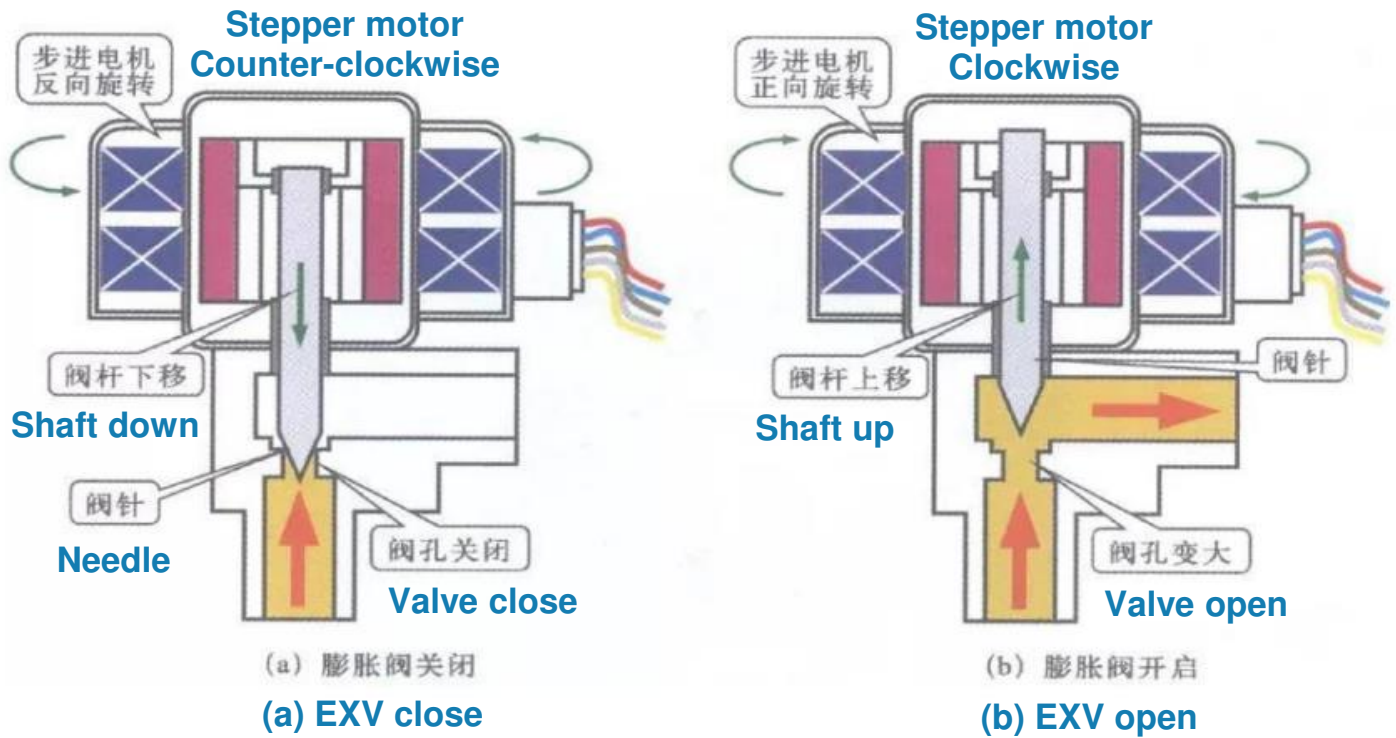
## Sanhua (002050.SZ, covered by Shelley Wang)

**Sanhua is Tesla's primary thermal supplier.** Sanhua supplies thermal management components such as electronic expansion valves (EXV), as well as the thermal module to Tesla. It has been the sole EXV supplier to Tesla so far, and Tesla contributed 15-20% of Sanhua's total revenue in 2023.

**Sanhua sees similarities between auto and robotic parts.** Sanhua is in talks with Tesla to assemble actuators, according to our checks. In Sanhua's global depository receipts (GDR) prospectus, Sanhua further highlighted its know-how in humanoid robotic actuator, as Sanhua believes the actuator shares similar raw materials, mechanical structure and manufacturing process with EXV. For example, both components use aluminium, steel, and magnetic materials; and both transform electric signal to mechanical movements. However, key differences are that: 1) an actuator uses reducers for motion control vs. EXV which use hydraulic components; and 2) actuators require more advanced precision machining.

**US\$0.5 billion commitment to robotic parts business.** In January 2024, Sanhua announced it would invest >Rmb5 billion to build new plants in Hangzhou, China. This includes >Rmb3.8 billion (US\$0.5 billion) for robotic actuators and controllers. This is higher than the Rmb0.2 billion investment plan for robotic actuator stated in the GDR prospectus, which we believe suggests Sanhua's increasing confidence in its robotic parts business.

**Exhibit 79:** Sanhua sees similar working principles between EXV and actuators



Source: Company data, Morgan Stanley Research. EXV = electronic expansion valve

### Tuopu (601689.SS, covered by Shelley Wang)

**Tuopu supplies multiple parts to Tesla EVs.** Tuopu supplies thermal management modules (a competitor to Sanhua), chassis parts, and interior/exterior decorative parts to Tesla. Its content-per-vehicle can be up to Rmb13K (US\$1.8K). Tesla contributed 40-50% of Tuopu's total revenue in 2023.

**Tuopu competes with Sanhua to supply Tesla Optimus with actuators.** Similar to Sanhua, Tuopu is sending samples to Tesla, for both rotary and linear actuators. Tuopu has already recognized Rmb1.85 million (US\$250K) revenue in 2023, by supplying humanoid actuator samples.

**US\$0.7 billion commitment to robotic parts business.** Tuopu has announced plans to invest >Rmb5 billion (US\$0.7 billion) to build a robotic electric drive plant in Ningbo, China, with Rmb3 billion to be spent on fixed asset investment. The investment mostly supports R&D, production and sales of electric drive systems for robots. This is similar to Sanhua's >Rmb3.8 billion investment in robotic parts, which shows Chinese suppliers' ambitions to become global robotics suppliers and their growing conviction in their customers' robotic businesses.

# Sector Adjacencies — Industries Ripe for Disruption

We believe the potential impacts from humanoids span across almost every industry involved in the physical rendering of goods or services (autos, metals and mining, industrial manufacturing, software, tech, cybersecurity, aerospace & defense, healthcare, consumer, food services etc.).

In the following sections, we detail what we believe are the sectors most likely to adopt humanoids in their day-to-day operations. Based on the results from our proprietary sector survey, the top four sectors that have the most physical labor, ongoing labor headwinds, and have a realistic path to adopting humanoids are: Automotive, Transportation & Logistics, Oil & Gas, and Restaurants. We've also included a case study on Amazon. As such, each respective sector team below expanded upon the nature of physical labor intensity and the humanoid opportunity.

**Exhibit 80:** We see 4 sectors as the most likely adopters of humanoids: Automotive, Transportation & Logistics, Restaurants, and Oil & Gas.

## Sectors Most Likely to Adopt Humanoids



Automotive



Transportation & Logistics

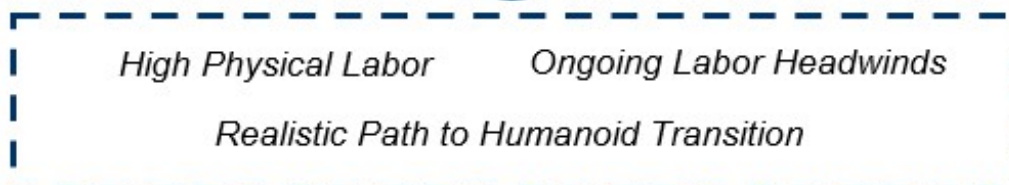


Restaurants



Oil & Gas

*Common Traits*



Source: Morgan Stanley Research

## Automotive

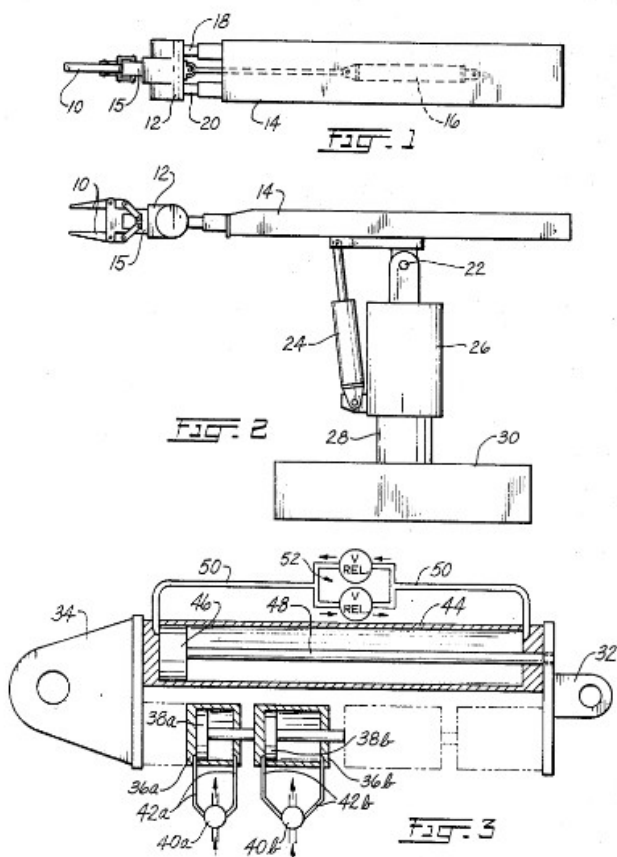
Adam Jonas

**Humanoids would be an extension of a century+ trend toward automation/efficiency in the Automotive industry.** Since the advent of the automobile in the late 1800s, auto manufacturing has been one of the most capital and labor intense industries in the world. As a result, the industry has continually pushed for new ways to cut costs out of production. In 1908, Henry Ford enabled practical, cost-effective mass-production of automobiles with the introduction of the assembly line. Decades later, WWII forced automakers and

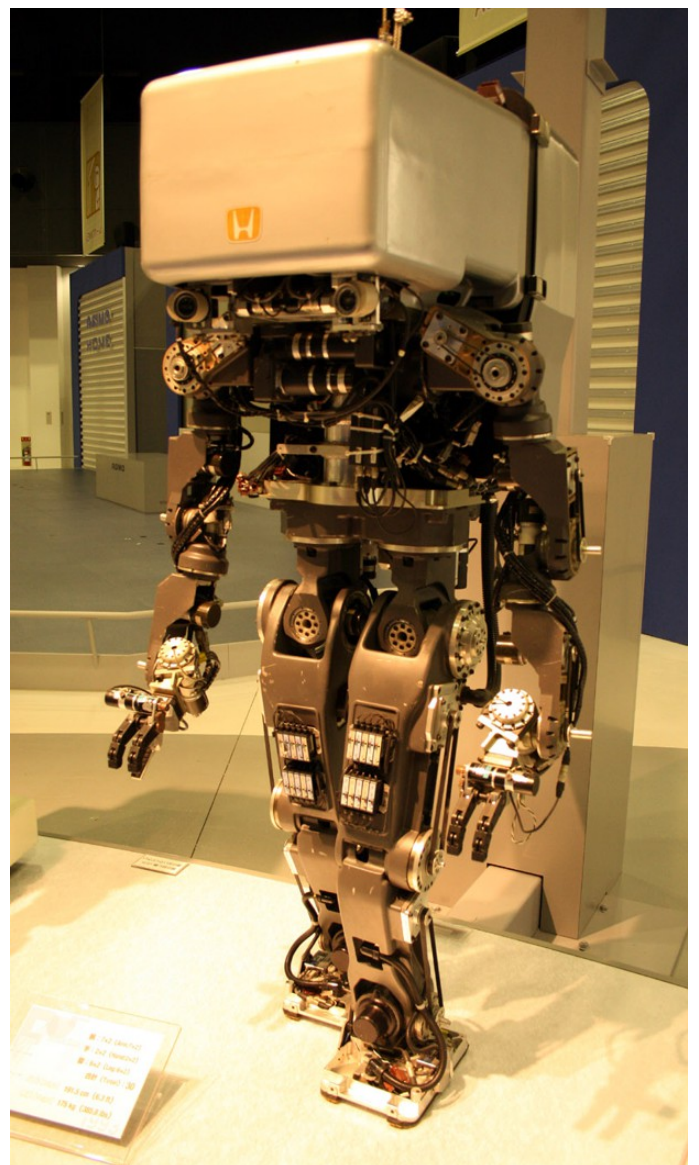
the rest of the global industrial supply chain to focus on new efficiencies and methods of automation. Then, in 1961, with the advent of computers, General Motors introduced the world's first industrial robot at its Inland Fisher plant in New Jersey, leading to robots being common place at any major auto plant. Now, we see potential that the advent of AI leads an eventual humanoid-revolution in automotive production.

**Exhibit 81:** "Unimate," the world's first major industrial robot, was introduced in 1961 at General Motor's Inland Fisher Guide Plant in New Jersey

**Exhibit 82:** Honda has been designing humanoid robots since 1986. Shown here is Honda's P1 (Prototype 1) released in 1993.



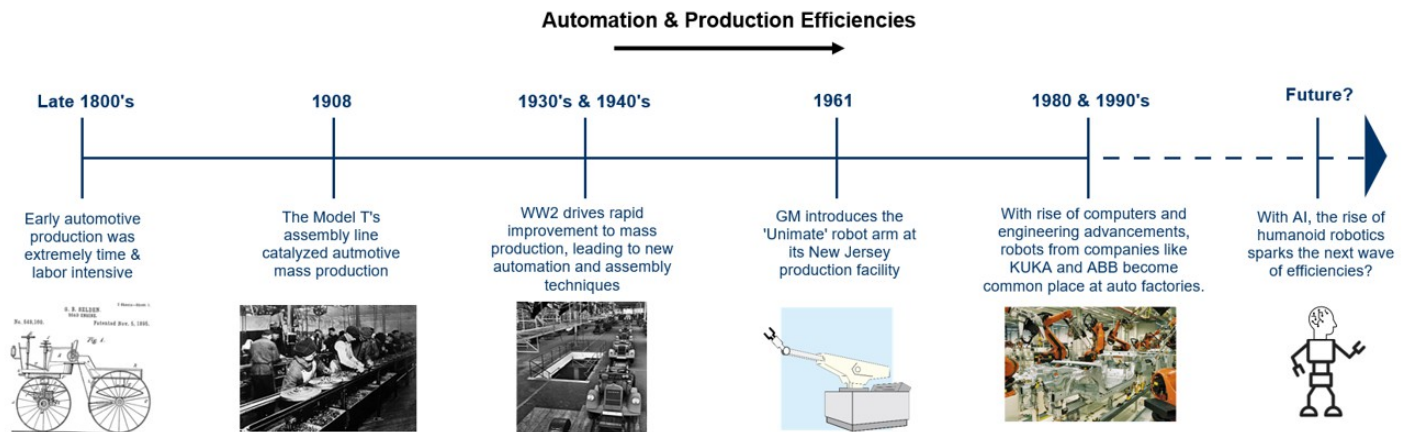
Note: Patent ID US-3476266-A by George Devol, the inventor of 'Unimate'.  
Source: US Patent Office



Source: Wikipedia, Honda



**Exhibit 83:** Today, "robots" have become common place at any automotive manufacturing plant. It may not be long until humanoids join the mix...

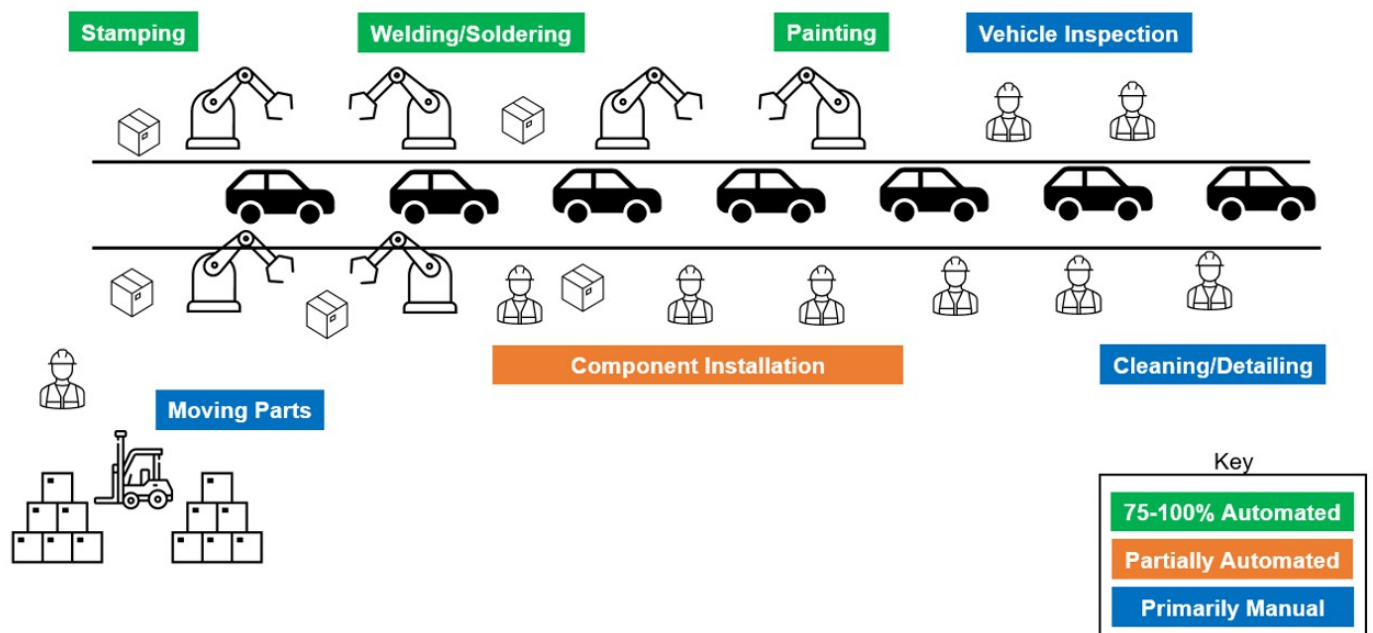


Source: Wikipedia, Morgan Stanley Research

**After decades of increasing automation, automotive production today is still a very labor-intensive process.** While any OEM production line today will feature a number of "robots," the overall process is still very labor intensive. Automation is currently concentrated in specific areas such as stamping, welding, and painting. However, a significant amount of manual labor goes into moving components around the assembly floor, frequently inspecting vehicles during production, and fastening complex parts to the vehicle frame (wiring, interior components, etc.). And we note this only represents the final stage of the auto supply chain. For the

suppliers, the process can be even more labor intensive. Components such as wiring and seats have historically been nearly impossible to effectively automate because of the precise human dexterity required. As a result, major suppliers such as Aptiv, Magna, and Lear have workforces of 150k+ employees, ~5x the median industrial company in the S&P 500. Initial applications for humanoid robotics will likely begin with relatively basic tasks such as moving parts or inspecting vehicles. However, the future development of robotic hands with human-like dexterity could be the "unlock" to accelerate automation at all levels of the automotive supply chain.

**Exhibit 84:** While any OEM production line today will feature a number of 'robots', the overall process is still very labor intensive.

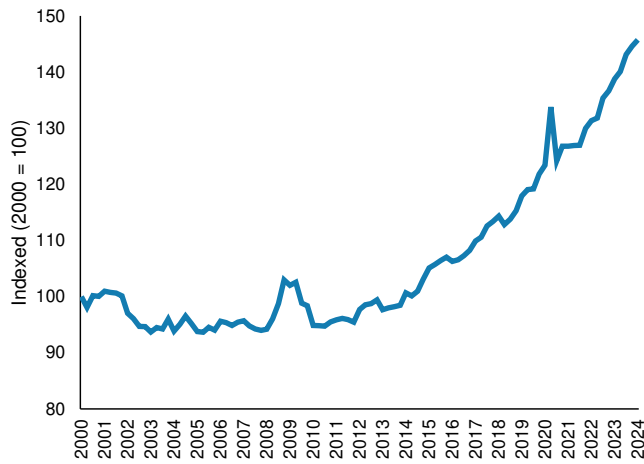


Note: Meant to be a generalization for the overall industry.

Source: Morgan Stanley Research

**This prevalence of unionized labor has only accelerated the push toward automation.** Globally, the auto industry is one of the most unionized industries in the world. As a result, the auto industry is notably exposed to sudden labor cost inflation (Ford estimates that the 2023 UAW contract adds \$850-900 to the cost of an average car) and labor disruption (the 2023 UAW strike and resulting lost volume cost F and GM \$1.7 billion and \$1.1 billion worth of EBIT, respectively). In our view, the auto industry is likely to look to continued automation as a method of mitigating the headwind caused by unionized labor.

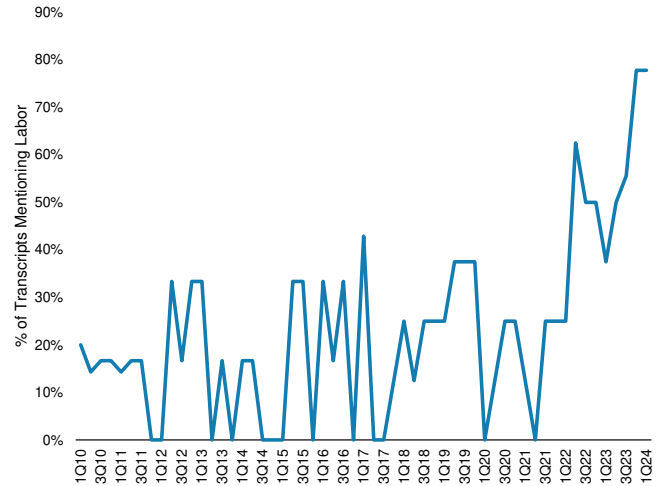
**Exhibit 85:** Unit Labor Costs of US Manufacturing Sector



Note: Unit labor costs represent the cost of labor required to produce one unit of output. We show total manufacturing as updated data for auto manufacturing, specifically, is not available.

Source: Bureau of Labor Statistics, Morgan Stanley Research

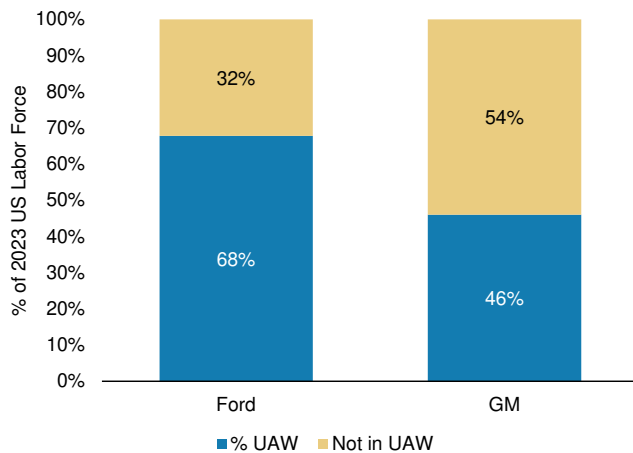
**Exhibit 86:** % of Transcripts Mentioning "Labor" and Related Terms since 2010: Legacy OEMs and Suppliers.



Note: Refers to quarter at which event occurred. For example, 4Q23 earnings calls would fall into 1Q24. Includes ADNT, APTV, AXL, BWA, F, GM, LEA, PHIN, VC.

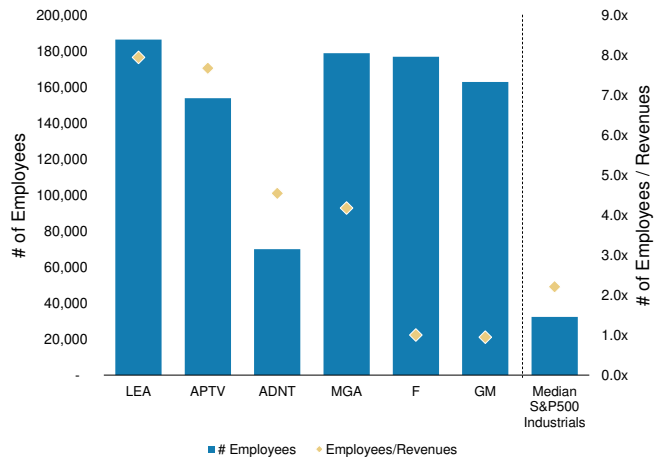
Source: AlphaWise, Morgan Stanley Research

**Exhibit 87:** A notable amount of OEM labor is unionized.



Source: Company Data, Morgan Stanley Research

**Exhibit 88:** # of Employees: F, GM, and notable labor-intensive suppliers vs. the median S&P 500 industrial company.



Note: As of most recent 10-K.

Source: FactSet, Company Data, Morgan Stanley Research



**Exhibit 89:** Assuming that a humanoid costs \$50k, we estimate a payback period for humanoids in US auto manufacturing ranging from ~6 to 13.5 months.

US Auto Manufacturing Payback Period					
Worker Type	Lower Wage		Avg. Wage (BLS)		Higher Wage
Average Hourly Earnings	\$	20.00	\$	30.27	\$ 45.00
Average Weekly Hours		42.9		42.9	42.9
Annual Salary	\$	44,616	\$	67,526	\$ 100,386
Monthly Salary	\$	3,728	\$	5,642	\$ 8,388
Assumed Humanoid Cost	\$	50,000	\$	50,000	\$ 50,000
/ Monthly Salary	\$	3,728	\$	5,642	\$ 8,388
<b>Payback Period (Months)</b>		<b>13.4</b>		<b>8.9</b>	<b>6.0</b>

Note: We ignore routine maintenance/energy/operational costs which would likely have a modest impact on the paybacks shown in this exhibit. Uses BLS average weekly working hours for US automotive workers.

Source: BLS, Morgan Stanley Research

**Auto OEMs have been closely tied to humanoid research since its early inceptions.** In 1986, as modern humanoid research was beginning to take off, Honda released its first E-Series (Experimental) robot and subsequently remained at the forefront of humanoid design through its eventual creation of ASIMO. Since then, an array of auto OEMs have made their own forays in humanoid robotics development, including Tesla (Optimus), Toyota (Toyota Research Institute), and XPENG (XPENG Robotics).

**Looking forward, we believe Tesla is primed to be one of the single-greatest enablers of humanoid robotics.** Tesla's 2021 announcement and subsequent advancements with "Optimus" have quickly moved humanoids to the spotlight of auto innovation. As of 1Q24, CEO Elon Musk believes Optimus will be performing useful tasks in Tesla factories by the end of 2024 with the robot being sold externally by the end of 2025. We believe the company's unique combination of compute power, AI and engineering talent, significant data capture opportunities, and strong financial footing relative to other players sets the stage for Tesla to be a clear winner in humanoid robotics (for more details, see the 'Tesla's Optimus: The Case for Tesla as an AI Enabler' and 'Optimus Prime(r)' sections).

**Exhibit 90:** Payback Periods of Humanoids in US Auto Manufacturing under Various Potential Humanoid Costs Scenarios.

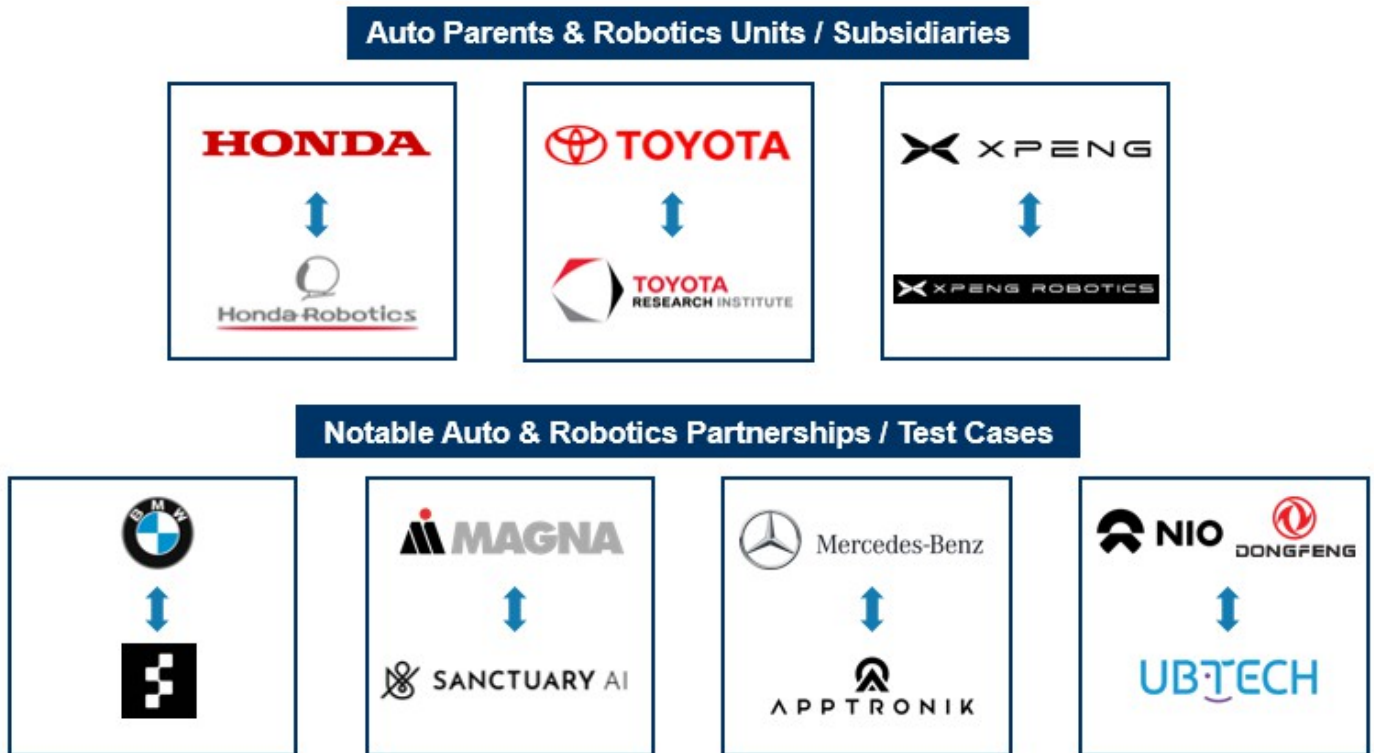


Source: BLS, Morgan Stanley Research

**We note a multitude of global OEMs and auto suppliers have also announced partnerships and testing agreements with humanoid startups:**

- **BMW/Figure:** In January 2024, [BMW and Figure](#) announced an agreement to explore potential use cases for Figure's upcoming humanoid robot, with deployment expected at BMW's Spartanburg, South Carolina, plant.
- **Magna/Sanctuary AI:** In April 2024, [Magna and Sanctuary AI](#) announced a partnership to deploy "Phoenix" humanoid robots at Magna's manufacturing plants while increasing Magna's investment in the startup company. Magna has been an investor in Sanctuary since 2021.
- **Mercedes/Apptronic:** In March 2024, [Mercedes and Apptronic](#) announced a partnership to find automotive applications for Apptronic's "Apollo" humanoid robots. Initial use cases include carrying parts to a production line, inspecting components, and delivering totes.
- **UBTech/NIO & Dongfeng:** In February 2024, UBTech released a video of its upcoming "Walker S" robot [working at a NIO BEV factory](#). In the video, the robot inspected the insides of vehicles in a production line and applied NIO logos to the hoods. Later, in June 2024, the company announced a [partnership with DongFeng](#) to deploy Walker S with Dongfeng's Liuzhou Motor subsidiary.

**Exhibit 91:** Notable Partnerships and Parent/Subsidiary Relationships Between Automotive OEMs and Humanoid Robotics Developers



Source: Company Websites, Morgan Stanley Research

**Exhibit 92:** Aptronik "Apollo" Robot on a Mercedes production line.



Source: Aptronik, Mercedes

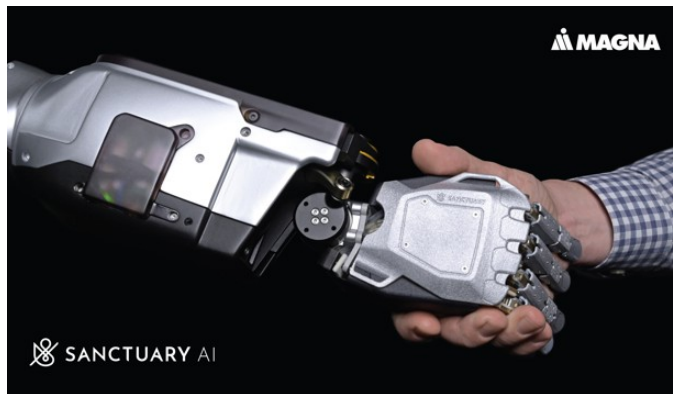
**Exhibit 93:** UBTECH "Walker S" inspecting a NIO Vehicle.



Source: NIO, UBTECH

**Exhibit 94:** Optimus Robots Walking in a Tesla Facility.

Source: Tesla











**Exhibit 95:** Sanctuary AI and Magna.

Source: Sanctuary AI, Magna

**Key beneficiaries & enablers in our global autos coverage include:**

- Tesla (TSLA):** We see Tesla as an enabler and differentiated competitor in the race toward humanoid labor disruption, with in-house custom silicon efforts tailored to the Tesla use case, a high-quality and exponentially growing data set, a heavy global manufacturing footprint consisting of "disruptable" labor, vertically integrated hardware and software, best in class talent, a strong balance sheet with access to capital, and an existing fleet of sensor encrusted robots already making life or death decisions in highly unpredictable environment (every Tesla vehicle on the road). *For more details, see the 'Tesla's Optimus: The Case for Tesla as an AI Enabler' section.*
- Mobileye (MBLY):** We believe MBLY has the capabilities to be an enabler of humanoid robotics through the application of its autonomous mobility technology to humanoid robot navigation. We also note that CEO Amnon Shashua recently founded a humanoid robotics startup (Mentee Robotics), which could have synergies with Mobileye.
- Other major global OEMs actively developing humanoids:** This includes Toyota (7203.T), which is developing the T-HR3 robot through Toyota Research Institute, and XPeng (9868.HK) whose robotics subsidiary is actively developing the PX5 robot. Like Tesla, we see these companies as both beneficiaries and enablers due to potential synergies between the robotics and core autos businesses.
- Other major global OEMs likely to implement humanoids in production:** We see BMW (BMWG.DE), BYD (1211.HK), Ford (F), General Motors (GM), Mercedes-Benz (MBGn.DE), and Stellantis (STLA) as key beneficiaries given the potential humanoids have to reduce labor costs at all levels of the auto supply chain, minimize the potential for disruption from union labor strikes, and increase the pace of output. We note that both BMW and Mercedes are actively testing humanoids at their North American production facilities.

Exhibit 96: Major Enablers and Beneficiaries in Global Autos.

Most Notable Humanoid Beneficiaries/Enablers: Autos		
Company	Ticker	Beneficiary/Enabler
	BMWG.DE	Beneficiary
	1211.HK	Beneficiary
	F	Beneficiary
	GM	Beneficiary
 Mercedes-Benz	MBGn.DE	Beneficiary
	MBLY	Enabler
	STLA	Beneficiary
	TSLA	Enabler & Beneficiary
	7203.T	Enabler & Beneficiary
	9868.HK	Enabler & Beneficiary

Note: Alphabetical order.

Source: Morgan Stanley Research

## Transportation and Logistics

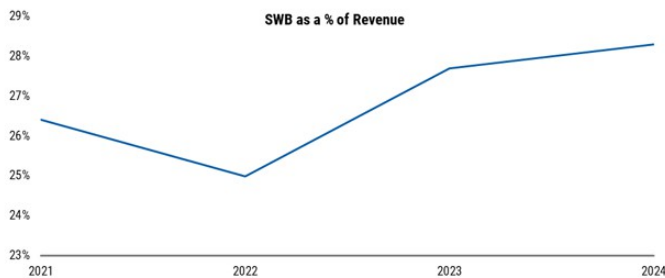
Ravi Shanker

**Few sectors in the US economy are likely to be as impacted by the advent of automation as Freight Transportation & Logistics.** This is due to the combination four main factors:

1. This sector is one of the largest, if not the largest, private sector employer (see [Exhibit 30](#)).
2. This sector has one of the highest employee casualty rates in the economy (see [Exhibit 30](#)).

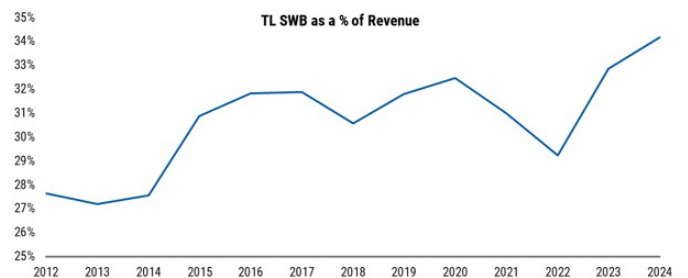
3. This sector has one of the highest labor cost exposure as a percentage of total costs of any industry (see [Exhibit 97](#)).
4. It is a relatively skilled job but with relatively low pay and an unfavorable lifestyle that does not attract younger/incremental labor participation.

**Exhibit 97:** Across our freight coverage, Salary, Wages & Benefits (SWB) as a % of revenue increased in 2023 and is expected to increase again in 2024



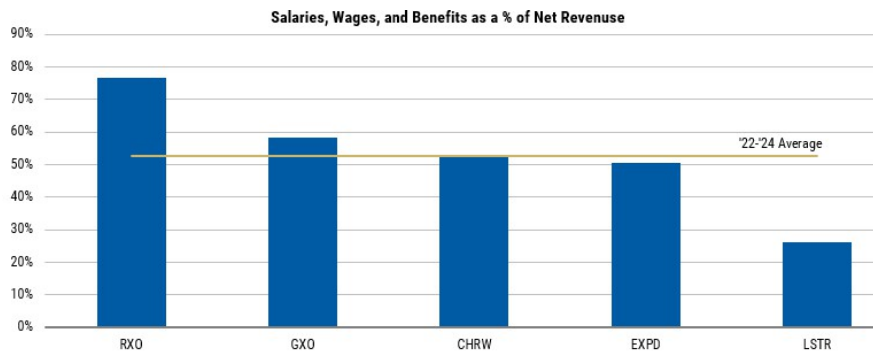
Source: Company Data, Morgan Stanley Research

**Exhibit 98:** TL as a % of SWB has seen an increase over the last 10+ years



Source: Company Data, Morgan Stanley Research

**Exhibit 99:** SWB as a % of net revenue at 3PLs reaches nearly 80% at the high end



Source: Company Data, Morgan Stanley Research

**The industry is acutely aware of the labor challenges it faces given the nature of the job.** This is further exacerbated by new regulations and a step up in compliance scrutiny with regulation such as:

- The Drug and Alcohol Clearinghouse (January 2020)
- The implementation of AB5 (2022)



## The Drug and Alcohol Clearinghouse

In January 2020, the use of the Drug and Alcohol Clearinghouse became mandatory. The FMCSA established the Commercial Driver’s License (CDL) Drug and Alcohol Clearinghouse which is a database that stores information on violations of the DOT controlled substances and alcohol program for holders of CDLs with the goal of more easily identifying drivers who are prohibited from operating a CMV based on such violations. **It was put in place to prevent drivers who commit a violation while working for one carrier from failing to report it to another carrier (as they are required) when looking for a new job.** Employers must check the Clearinghouse in the hiring processes and annually for each driver that they employ.

Exhibit 100: Drug & Alcohol Clearing House: How It Works

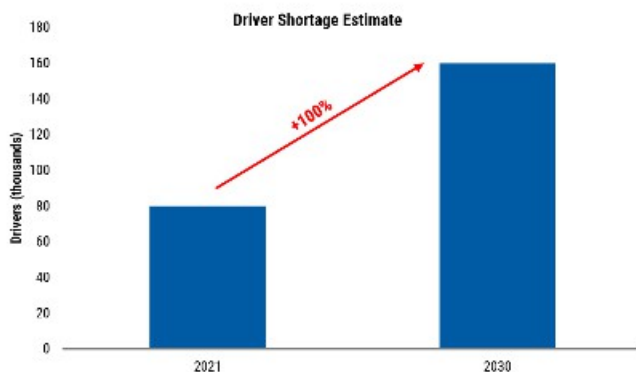


Source: FMCSA, Morgan Stanley Research

## California Assembly Bill 5 (AB 5)

In addition to the Drug and Alcohol Clearinghouse, **we saw further supply side constraints from California Assembly Bill 5 (AB 5 for short) and similar proposed legislation in other states.** AB 5 seeks to limit the use of "Independent Contractor" employee status by implementing an "ABC" test for worker classification. The legislation was signed into law in September 2019, but did not become effective until 2022 after several appeals took place. Given the size and importance of the California economy, **we see this legislation as a headwind to Truck Owner Operators in California who classified employees as Independent Contractors.**

Exhibit 101: The ATA forecasts the driver shortage growing from 80k in 2021 to 160k by 2030



Source: ATA Driver Shortage Report 2021, Morgan Stanley Research

## Overall Driver Shortage

The driver shortage in the trucking industry is a well-known phenomena that has been weighing on the industry for some time — and yet the shortage only continues to grow with every upcycle. **Indeed the ATA forecasts the driver shortage growing from 80k in 2021 to 160k by 2030.** This has resulted in robust inflation in driver wages. We note salaries, wages and benefits as a percentage of revenue among our TL coverage has climbed from high-20% in the early 2010s to nearly 35% today. While some of this reflects a subdued revenue environment, we would note that even in 2022 at the peak of the greatest upcycle on record, SWB as a percentage of revenue was still 2 pct. pts higher than it was a decade ago.

Exhibit 102: TL as a % of SWB has seen an increase over the last 10+ years



Source: Company Data, Morgan Stanley Research



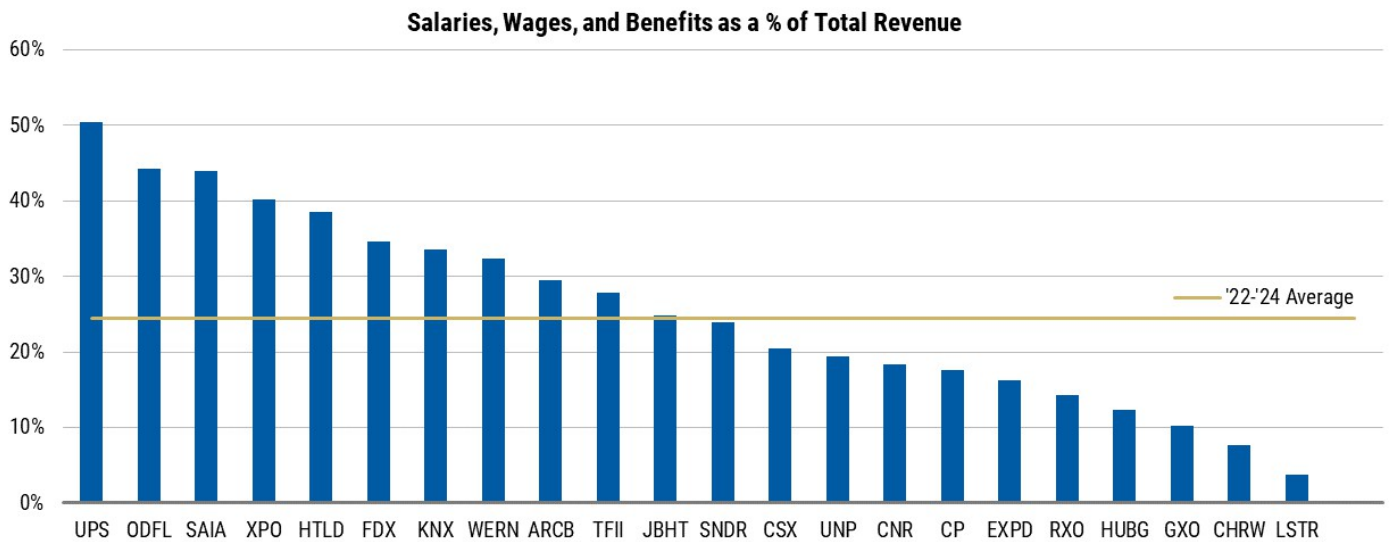
**How can humanoids help?** It is clear that automation needs to step in to solve the structural labor problems that this industry faces. **There are two primary types of automation in the space: (1) process automation, and (2) direct labor substitution**

**The Freight Transportation and Logistics industry has been on a path toward achieving process automation for the last 6-7 years.** Process automation is the attempt to remove the need for labor completely but having the process or system automatically complete the task. While this is a very labor intensive industry as noted earlier, it is also one of the largest industries in the world (\$1.3 trillion US TAM, \$5 trillion+ global TAM) that doesn't actually make anything, but just moves everyone else's stuff from Point A to Point B. As such, **it is largely a process function that can, in theory, be automated from start to finish.** Take the example of a truck brokerage transaction, that until recently had been entirely manually undertaken on a phone/fax machine but is now largely being automated from start to finish, in much the same way as summoning an Uber for a ride is a completely digital process from start to finish (including all but the most complex exception management).

**(2) Direct labor substitution.** The other application of automation is as a complement or substitute for humans. This is especially salient in applications that are either dangerous to humans or mundane or for whatever reason sees a labor shortage as highlighted above for truck drivers. This automation can be built in (in the example of autonomous trucks for example) or used as a direct add/substitute for humans (for example with cobots at a warehouse). **It is the latter use that is particularly suitable for humanoids.** Humanoids can be used to fill in for humans as a backup (truck driving), boost capabilities (ability to carry heavier weights, work longer hours) and effectively significantly boost human productivity (or fill in for jobs that humans do not want to do).

**We see significant applications for humanoids in labor substitution functions across trucking and rail companies (especially TL trucking given driver shortages and dealing with autonomous trucking edge cases) as well as in warehousing.**

Exhibit 103: SWB as a % of Revenue across our freight coverage



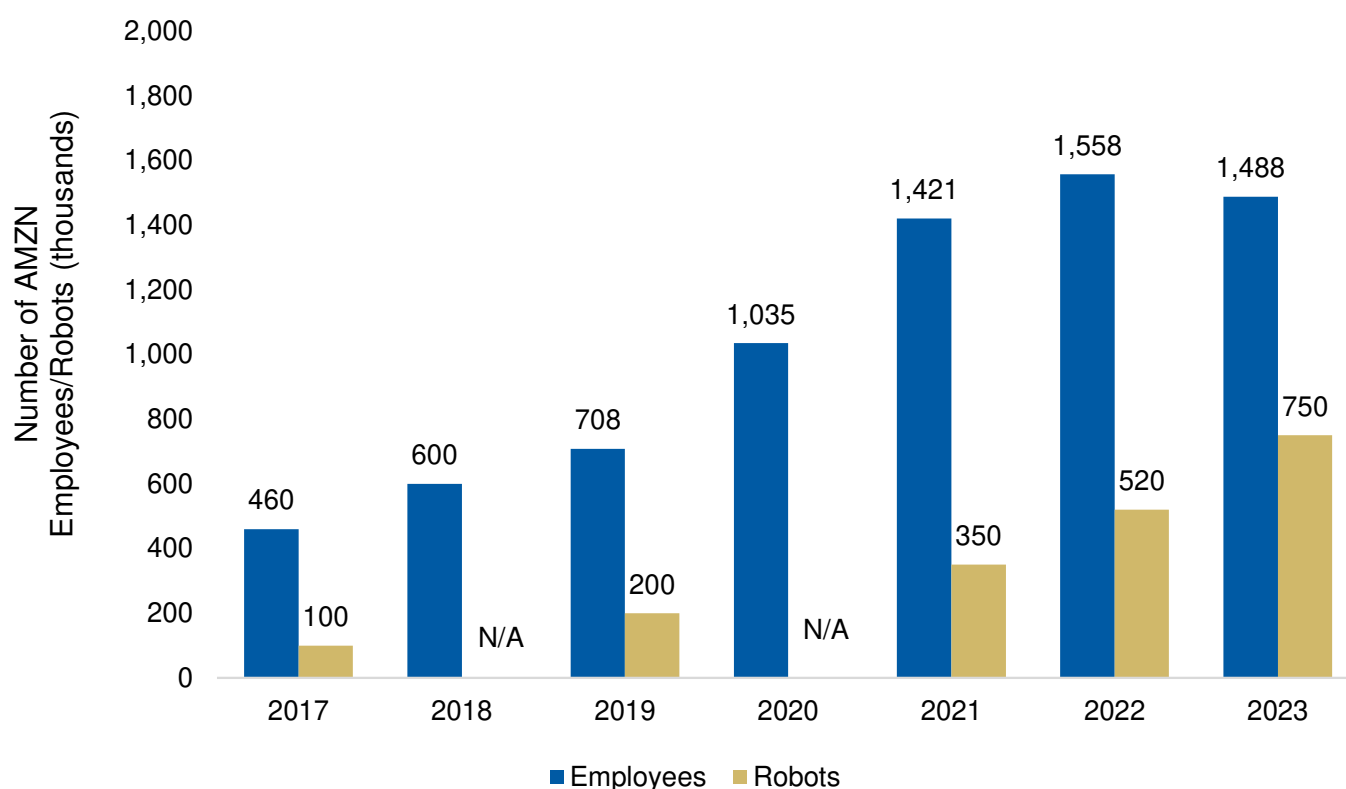
Source: Company Data, Morgan Stanley Research

## Amazon

Brian Nowak

**AMZN Is a Leading Player in Robotics Development and Deployment:** Robotics have always played a key part in AMZN's best in class logistics efficiency. AMZN purchased Kiva Systems in 2012 for \$775 million, giving the company access to mobile robots that facilitate the fulfillment of orders in AMZN's fulfillment centers. The Kiva robots sit within closed fence areas, carrying products to human workers for picking and packing. Since the acquisition of Kiva, AMZN has developed a wide array of robotic capabilities, including Proteus, AMZN's first fully autonomous mobile robot that can operate in the same physical space as humans and Cardinal, a robot designed to pick packages out of a pile, read the label and place it in a cart. **In all, AMZN has scaled its fleet of robots from 100k in 2017 to 750k in 2023, with the ratio of employees to humans at AMZN going from ~4.5:1.0 to ~2:1 during that time period. In 2023 alone, we estimate AMZN spent ~\$9 billion on robotics related capex as it continues to look to bring this technology into its facilities.**

**Exhibit 104:** AMZN has scaled its fleet of robots from 100k in 2017 to 750k in 2023, with the ratio of employees to humans at AMZN going from ~4.5:1.0 to ~2:1 during that time period



Source: Company Data, Morgan Stanley Research

**Digit Represents a Push into Humanoid Robots:** In addition to Kiva, Proteus and Cardinal, AMZN is partnering with Agility Robotics (AMZN is invested in Agility through its Industrial Innovation Fund), and testing its bipedal robot "Digit." Digit is a 5-foot-9-inch robot that can lift up to 35lbs, weighs approximately the same as a person and has a reach of floor to 5-foot-6 inches. Digit has paddles at the end of its arms (instead of hands) and it can pick up boxes when it uses both limbs together. Digit's clamp like approach sidesteps the difficult hurdle of replicating human hands. **Today, Digit is being tested**

**in AMZN's robotics R&D facility in Seattle and is limited to the basic task of picking empty tote bins off a shelf and bringing them a few feet to a conveyor belt** (see [Exhibit 105](#)). Digit's size and shape are well suited for buildings that are designed for humans (unlike AMZN's Kiva robots which require specific/unique space footprints). That said, reports suggest Digit still takes longer than an Amazon worker to complete its main task and needs to be recharged every couple of hours due to a limited battery life. To mitigate the limited battery life, AMZN is testing the use of robots in shifts, i.e., having

some robots work, while other robots charge (see [Exhibit 106](#)). Ultimately, AMZN sees a long term opportunity to scale Digit (or something similar) to collaboratively work with human employees across other warehouse tasks, e.g. unloading trucks overnight so boxes are ready for human workers for the daytime shift. Today, we believe Digit costs ~\$250,000, and when compared to the median annual average cost of an AMZN worker in the US (~\$48,000 including benefits), **we estimate that it would take ~five years to**

**Exhibit 105:** Today, Digit's role in AMZN's warehouses is limited to the basic task of picking empty tote bins off a shelf and bringing them a few feet to a conveyor belt.



Source: Company Data, Morgan Stanley Research

**breakeven on a Digit robot today assuming the Robot worked the same number of hours as a human. That said, it is early days, and as Agility Robotics scales (NTM target of tens-to-hundreds of units, LT target of 10,000 units) and gets more efficient, we expect the asking price for its robot will fall (latest Digit robot already expected to cost less than \$250k) and Digit's productivity will improve (i.e., 1 robot potentially doing the work of 1 or more humans).**

**Exhibit 106:** Digit still takes longer than human workers to complete its task and needs to be recharged every couple of hours due to limited battery life.



Source: Company Data, Morgan Stanley Research

## Restaurants

Brian Harbour

### Why does automation/humanoid robots matter for restaurants?

The industry has not historically been ripe for automation, as other industries have higher pay, more dangerous tasks, and are harder to staff. This has shifted though, with significant wage inflation, more difficulty staffing, and structural drivers that likely mean this continues.

**1) The industry's workforce is large, and ~30% of revenue goes to cover labor cost.** Foodservice workers number ~13 million in just the US, or ~9% of the American workforce, and the majority of Americans have worked a foodservice job at some point in their life. This is mostly low cost, (relatively) low skill, non-unionized work and not particularly dangerous compared to some industries, hence why automation hasn't been widespread yet. The industry has been built largely on this low cost labor force, but it's no longer particularly low cost. Typically, at least 30% of a restaurant's revenue covers direct labor cost (wages, benefits, managers) and this figure has generally moved higher for most of our coverage over the past decade. Any producer of humanoid robots would likely look to this pool of labor as an interesting addressable market. As we detail in the table below, many foodservice jobs have the potential to be automated though not all may be addressable via humanoid robotics.

**2) Labor tends to be the biggest pain point for operators/owners, and a structural cost pressure.** This is visible in industry wage cost data, and over the long term, a generally rising labor cost ratio has pressured restaurant unit economics. Additionally, hourly worker turnover tends to be above 100% annually for this industry, and hiring and training adds further cost. At any industry conference, operators will usually cite cost, availability, quality, and regulation of labor as a top challenge. Operators doing well will often attribute success to their people, on the flip side. While labor availability and inflationary pressures now are not nearly as bad as circa ~two years ago, regulation and other structural pressures likely mean this challenge doesn't go away.

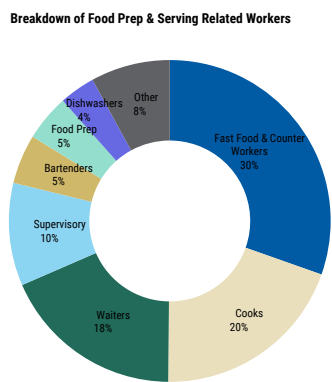
**3) While automation will play an increasingly important role for restaurants, it won't all come entirely via humanoid robotics and we don't envision a world where all labor is removed from stores, especially in the front of the house.** We don't believe robots will entirely replace humans within restaurants nor do we advocate for this, with front of house workers like waiters likely remaining key to customer interaction, and the creative profession of a chef not likely to change. We think automation is more likely at the back of house, fast food, and cashier positions (as has already happened with kiosk ordering). Humanoids could eventually handle tasks associated with production/prep, simple cooking, clean up and other less desirable tasks while people can focus on hospitality and guest interaction, and the more creative side of the industry.

**Exhibit 107:** US foodservice labor snapshot: The vast majority of foodservice workers (upwards of 80%) are directly involved in the food prep and serving process and we believe most categories have a mid-high ability to be automated (although not necessarily via humanoids). Likelihood to automate represents our own view here. The typical wage for these jobs today ranges from \$14-17/hr nationally though wage rate inflation has been sticky in the 3-5% range, which we expect to continue.

Breakdown of Foodservice Labor	# of Employees	Median Wage	Mean Wage	Mean Annual Wage	Est Total Labor Dollars Spent (\$B)	Likelihood to Automate
<b>Total Employment</b>	<b>151,853,170</b>	<b>\$23.11</b>	<b>\$31.48</b>	<b>\$65,470</b>		
Food Prep and Serving Related Workers	13,247,870					
Fast Food & Counter Workers	3,676,580	\$14.20	\$14.48	\$30,110	\$110.7	High
Cooks	2,839,610					
Restaurant Cooks	1,412,350	\$17.20	\$17.34	\$36,060	\$50.9	Mid
Fast Food Cooks	673,490	\$14.07	\$14.31	\$29,760	\$20.0	High
Waiters	2,237,850	\$15.36	\$17.56	\$36,530	\$81.7	Mid
Supervisory	1,176,540	\$18.52	\$20.82	\$43,310	\$51.0	Low
Food Prep	879,610	\$15.59	\$15.85	\$32,960	\$29.0	High
Bartenders	711,140	\$15.15	\$17.83	\$37,090	\$26.4	Mid
Dishwashers	463,940	\$15.00	\$15.22	\$31,650	\$14.7	High
Other Food Prep and Serving Related	1,262,600					Mid

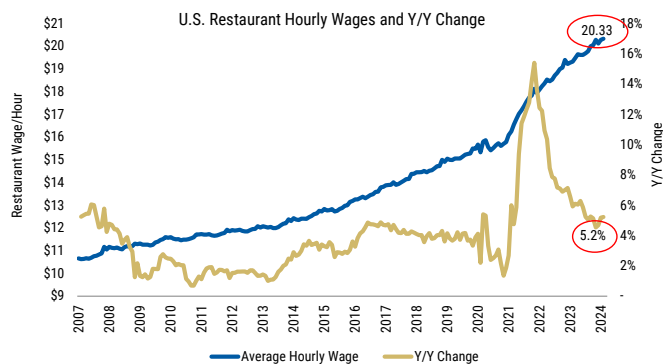
Source: US BLS OEWS survey, as of May 2023, Morgan Stanley Research

**Exhibit 108:** Food prep and serving related workers by type. Most of the categories, outside of supervisory and waiters could be automated to some extent over time though not necessarily via humanoid robotics.



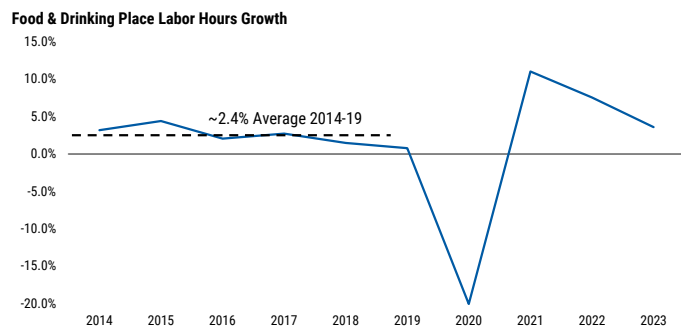
Source: US BLS OEWS, May 2023, Morgan Stanley Research

**Exhibit 109:** The restaurant industry average hourly wage is now \$20.33, running ~5% higher y/y. We'd note this data set shows a higher wage than the granular OEWS data in the table above and the two sources are different.



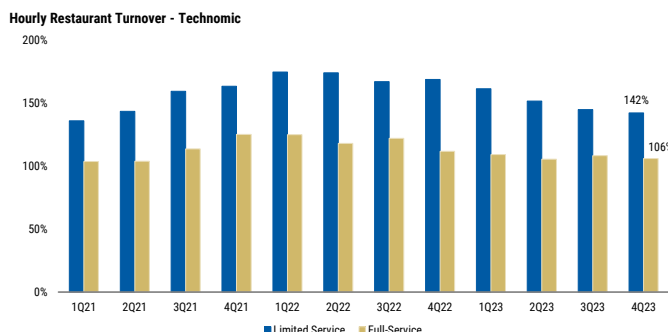
Source: US BLS, Morgan Stanley Research

**Exhibit 110:** In addition to 3-5% wage rate inflation, labor hours have steadily risen over time.



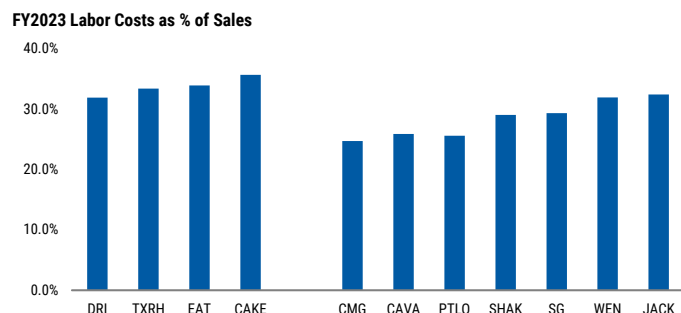
Source: US BLS, Morgan Stanley Research

**Exhibit 111:** Hourly restaurant worker turnover is typically over ~100% and can be as high as ~150% for quick-service brands, per Technomic.



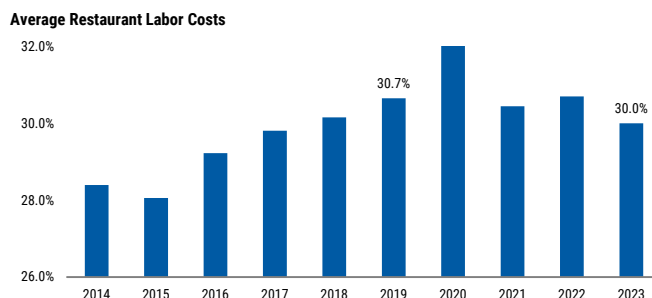
Source: Technomic, Morgan Stanley Research

**Exhibit 112:** Direct labor costs are typically lower for fast-casual brands (can be below 30% of sales) though are mostly in the low-mid 30% range for fast food and full-service.



Source: Company data, Morgan Stanley Research

**Exhibit 113:** Average restaurant direct labor costs (% of sales) have steadily risen over the last decade, given persistent labor cost inflation not fully offset by pricing.



Source: Company data, Morgan Stanley Research

**What's likely to continue to fuel the labor challenge?** While the labor challenge has eased materially vs. 1-2 years ago, we don't think it's going anywhere, and there are some structural drivers of this:

- **Immigration:** Seemingly a tailwind recently as our US Economics team has noted, but both political parties have voiced support for restrictions on border policy and the Biden administration has moved on this via executive order. This could constrain supply as migrants may often take jobs in foodservice.
- **Wage regulation and minimum wage:** California in 2024 enacted a \$20 minimum wage for fast food chains, and it's possible other states follow this over time. Some states and municipalities have moved to eliminate tipped minimum wages (applicable for full service), or increased minimum wages generally, sometimes above the rate of inflation. Relative low wages in the restaurant industry are a popular political punching bag given the size of the workforce and its

visibility. There are other regulatory changes that could add to this pressure as well.

- **The usual culprits — availability, inconsistency, retention:** These are not new, but it's worth remembering that in the restaurant industry, hourly worker turnover is often in the 125%+ range (lower for full service, higher for limited service), part time work is common, hiring is a constant process, and given turnover, consistent execution can be a challenge. Lower skill, lower pay work means these are inherent challenges over time and workers tend to be younger, though there is perhaps less willingness to join the industry today, meaning that availability has been more of a challenge recently and wage inflation in this industry is above the normal rate in the economy and has been for some time.

**What's been done so far from an automation perspective?**

Robotics companies focused on humanoid products have looked at the restaurant industry though what's actually been tested or



deployed so far is more often stationary purpose-built equipment to automate key steps. Arm-like robots, similar to those used in factories are used in some restaurants, but none of this technology is yet widespread. Current initiatives to highlight include:

- **Sweetgreen's Infinite Kitchen:** This is a fully automated production line designed in house (following the acquisition of Spyce, which created an automated concept several years ago) to assemble salads and plates with substantial labor savings accordingly (10 ppt margin uplift cited by the company as of May 2024). It went live in 2023 and will be in over a dozen stores by the end of this year, including some older stores retrofitted with the equipment. The company aims to lean into this for future growth, creating a fundamentally lighter labor model restaurant with better production throughput. This type of automation has yet to be done at scale by a national brand.
- **Chipotle's Hyphen and other tests:** Hyphen (a startup which CMG invested in) has developed an automated production line for CMG's burrito bowls, which is still in test and not live in a restaurant yet, but should be this year. It aims to replace the second production line in stores (which currently handles mobile and delivery orders) to reduce labor intensity and speed up production. Chipotle has also tested Chippy (from Miso Robotics; see below) for frying chips, though it appears the test has ended, and Autocado, from Vebu, which automates avocado peeling and cutting, a time consuming manual process done before making fresh guacamole.
- **Robotic arms from Miso Robotics, and others:** Miso's robotic arm, Flippy (Chippy in CMG's iteration) has gotten

media attention and been tested by a number of chains mainly operating fryers, though the name alludes to flipping burgers as well. Several chains report operating it successfully and have broad tests, though others have pulled back on using it, sometimes based on space concerns or perhaps questions about economic viability.

- **Other examples:** There are some one-off examples of automated restaurants, though at scale the use cases so far have been more modest. Chains including McDonald's (MCD) use automated drink dispensers and Domino's (DPZ) is rolling out an automated dough press. CMG founder Steve Ells's new venture Kernel has one store open in NYC using a robotic arm from Kuka robotics to help prepare food. Automated coffee stands exist in many cities (and foreign countries including Japan), and Blank Street Coffee is not fully automated but uses machines that are partially automated compared to Starbucks (SBUX) or the industry standard. Bear Robotics offers a wheeled serving robot that can carry food or help bus tables and has been tested by some chains. Conveyor belt sushi is a well known concept that originated in Japan, where labor cost has long been an issue, and Kura Sushi (not covered) is expanding it in the US. There had been previous failures in this arena, including SoftBank-backed robotic pizza company Zume, most notably.
- **Automated delivery:** Here we are referring to drones or AVs to deliver food. AVs (such as the DPZ-Nuro partnership) have been tested for some time but have yet to scale and likely depend on broader AV adoption by third party delivery, as we don't expect restaurants to lead this charge.

**Exhibit 114:** Miso Robotics' "Flippy" automated arm can help operate a frying station or to flip burgers.



Source: Miso Robotics

**Exhibit 115:** Kernel, a new fast-casual addition in NYC, operates a digital-only store format that can function with just a few employees. The food production process is largely driven by robotics with employees only putting on the final assembly touches.



Source: GrubStreet, Kernel

**Exhibit 116:** Sweetgreen's Infinite Kitchen format (robotic assembly of bowls/salads) can operate with 4-5 employees in its stores and the two existing stores with the technology are seeing store-margins nearly 1,000 bps higher (high 20% range) vs the current store average.



Source: Sweetgreen

**Exhibit 118:** Autocado from VEBU could help cut CMG's guacamole prep time by ~50% as it automates the process of cutting and peeling avocados.



Source: Chipotle, Autocado

### What's the opportunity for humanoid robotics for restaurants?

**Humanoids vs automated static equipment:** Humanoids have not been talked about extensively in this industry, but as mentioned previously, the advantage is they can operate in existing spaces and layouts, an advantage for the 700k+ existing foodservice locations in the US, not to mention many more outside the US. Automated production lines (as Chipotle and Sweetgreen have unveiled) could work if they fit in existing footprints, or new stores are built around them, but retrofitting an existing store could be harder when one thinks about the broader industry. These production lines are inherently less flexible, and well suited to bowls or salads, less so to other types of food. Chipotle's Hyphen will only make bowls, not burritos and tacos. Good humanoid robotic technology over time could be more flexible and workable in existing store footprints.

**Exhibit 117:** Chipotle is developing a similar assembly technology though we expect this will mostly be used for digital orders and will be slower to roll out given it's still in its test kitchen currently.



Source: Chipotle

**Exhibit 119:** Automated drink dispenser from Miso Robotics.



Source: Miso Robotics

**What areas will be easier or more likely to automate? Food prep and cooking in limited service and some of full service.** By this we refer to frying almost anything, grilling, mixing, portioning ingredients, some ingredient prep, assembly of items like burgers and sandwiches. **Tasks like bussing and dishwashing that are key but less visible to customers.** There are early solutions to these but these roles are among the hardest to fill. **Cashiers** are already being replaced in many cases by kiosk ordering. This likely continues to fall away as a separate job.

**Harder to automate: Chefs in fine dining and some of casual dining** we assume won't go away as the demand for this craft won't change. **Servers and customer facing employees** we assume could be partly addressable but won't be replaced entirely except perhaps as a novelty (in a Star Wars-themed restaurant, perhaps) and customers

won't want this at experiential concepts across full service — it might seem unsettling at least early on. Help with bussing/carrying food could reduce the demands of the job though. **Certain cuisine types** have so far been harder to automate e.g., making burgers, sandwiches, burritos, tacos, and this may remain the case for some time, with bowls, pizza, and coffee easier to address, though the technology described in this report could get us much closer to being able to address a broad range of cuisines. Human-like dexterity would be needed to make tacos, for example. **Managerial positions** we assume are not affected.

## Key Beneficiaries in this Industry

**Fast Food:** Given the relatively simple nature of fast food products, importance of speed of service, lower price point, and the generally lower skill labor force and higher turnover, robotics appear to be well suited for these concepts. Pizza, beverage, and fried food would seem best suited, though the promise extends beyond this over time. The benefits could be seen across the industry in a similar way though **MCD** or **YUM** could be obvious targets given their size. Companies like **JACK**, **QSR**, or **WEN** could be followers (JACK has had some success with robotic arm tests). **It's important to note that these are highly franchised business models** so 1) franchisees have to agree to invest (humanoids could more likely be offered for rent — comments on this below), which can be harder to do quickly (or the parent company has to co-invest or otherwise incentivize new investment) and 2) if there is a bottom line benefit, this doesn't accrue directly to the listed parent franchisor. But franchisees that can operate more efficiently and more profitably should over time drive sales and unit growth that helps the parent.

**DPZ & WING** could be well suited toward broader automation as well as humanoids given relatively narrow menus and simpler food prep (potentially easier to automate food production) and the delivery/carry-out focus of the businesses (humanoids making your meal won't impact the customer experience) and majority digital sales mix. The in-store/human experience isn't as important as speed and convenience. Note these are also both franchised.

**SBUX** could arguably be a beneficiary since we view the beverage category as being among the more addressable, and SBUX is among the more affected on the labor cost and throughput side in our coverage (and it owns many of its own stores). The challenge, however, is SBUX's commitment to the business of 'human connection,' and thus leaning into humanoid robotics wouldn't really be on brand and could erode pricing power, which has long depended on the image of premium hand-crafted beverages. Automation may lose differentiation vs peers and this would be a fall from the origins as a place for

human connection and a "third place" for customers. Nor do we think the employee base would be inclined to accept this and there is not a "back of house" at most SBUX stores. Maybe SBUX is a later adopter, or given the majority of its business is drive thru or mobile order today, robotics could be complementary to handle that channel.

**Fast Casual — CMG and SG:** Two early leaders in automation so far, but from purpose-built equipment, which likely works better for bowl-based concepts like these (CMG sells more bowls than burritos) and both own their own stores vs franchise. For SG we don't envision this shifting given the work so far on Infinite Kitchen. CMG may still have the chance to pivot, if for some reason humanoid technology advances more over the next 5 years, ahead of broader Hyphen deployment. Both CMG and SG own and operate all stores and could see benefits to not only costs but also the top line via increased throughput. **CAVA** runs a similar business model to both CMG and SG and could be a fast follower in whatever works for these two. **SHAK** and **PTLO** have more in common with the rest of fast food (but are not franchised), and could benefit from humanoids over time, more so than purpose built equipment.

## Bucketing our coverage by high/medium/low potential exposure to the humanoid theme:

*Note the franchised vs owned distinction impacts whether cost savings from humanoids would flow through to the company, with the latter seeing more benefit. However, we're thinking about this broadly in terms of who could benefit from an operational, throughput, sales and franchisee health perspective, and which systems would be the best targets for humanoid adoption at scale. The medium and low buckets, plus PTLO and SHAK have greater company ownership and could see more labor cost savings flow through, but we do think some of the big fast food chains are easier targets. CMG and SG have existing automation initiatives also.*

**High:** Narrow menu and off-premise focused fast food — **DPZ** and **WING**. Most of the broader fast food group like **MCD**, **YUM**, **QSR**, **JACK**, **WEN**. **PTLO** and **SHAK** are considered fast casual but do not have a "walk the line" food assembly process and could also be key beneficiaries longer term.

**Medium:** **CAVA**, **CMG**, and **SG** likely benefit from automation but humanoid robotics could play a smaller part given ordering channels and format. **SBUX** as well, in our view, since we think it's addressable, as noted, but the culture, price point, and format make it less likely to be an early adopter.



**Low:** All of our full-service coverage including **DRI, TXRH, BLMN, CAKE, and EAT**. While these could potentially benefit in the back of the house and with tasks like bussing/dishwashing, the overall impact is likely more modest and these concepts are more experiential, where we think human labor persists longer. We'd note these are owned concepts, thus small changes in labor cost could have more bottom line benefit however, vs a franchised model.

**Foodservice Distribution:** We also cover **SYF, USFD, and PFGC**, the logistics providers that supply food to restaurants, which we have not covered here in detail, but we do think there could be applications for humanoids in their warehouses. These can be viewed through the same lens as other logistics companies or retailers with warehousing capacity.

#### How much would humanoid robots need to cost to make sense?

We don't know exactly, but with some exceptions, restaurants have tight capital budgets, and offering humanoids as a rental model, so they look more like a human employee, would make them much

more likely to be adopted. (Sci-Fi readers will note that Isaac Asimov's fictional US Robots was mainly in the business of robot leasing.) Below we outline what we view as the breakeven cost to replace one full time employee equivalent at a hypothetical 24-hour fast food restaurant. This assumes \$15/hr wage with three different employees working an 8-hour shift each with a 20% gross up of hourly pay for benefits and taxes. We also assume turnover and training costs, yielding nearly ~\$170k per year, or ~\$14k per month for this FTE. This does not include the intangible cost of lost productivity from employee turnover or hiring inconsistency. These assumptions can be flexed, but it shows the monthly cost that a hypothetical humanoid replacement would have to beat to make sense from the perspective of a cash flow-focused restaurant operator.

Of course, human labor costs likely go up over time while robotics technology should improve and may drive costs down. Humanoids don't incur payroll taxes but do consume energy, have a useful life, and there are tax implications of owning vs renting a robot vs. hiring a person, which we won't expand on here.

**Exhibit 120:** We estimate a full-time employee equivalent in a 24-hour fast food restaurant would cost about ~\$170k a year after accounting for hourly wages (at \$15), taxes, benefits and training costs.

Illustrative Annual Cost of a Full-Time Equivalent Employee in 24-Hour Restaurant	
Wages to Support Three Separate 8-Hour Shifts at \$15/hr	\$131,040
Gross Up for Benefits and Taxes (20%)	\$157,248
Training Costs Assuming ~133% Turnover and Cost is ~Three Weeks Pay	\$10,080
<b>Total Annual Cost of a 24-Hour FTE</b>	<b>\$167,328</b>
<b>Monthly Cost</b>	<b>\$13,944</b>

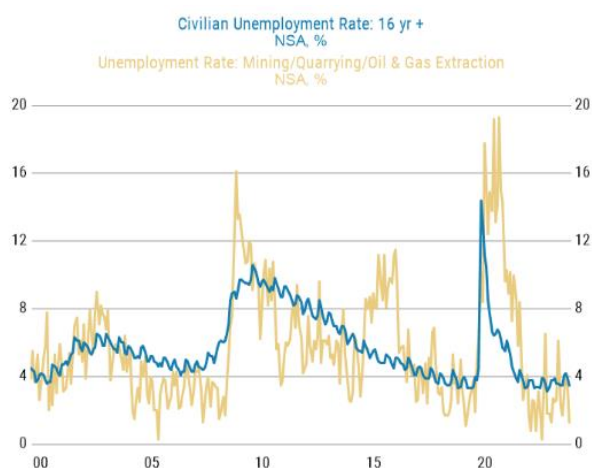
Source: Morgan Stanley Research

## Oil & Gas & Energy Services

Devin McDermott, Joe Laetsch & Dan Kutz

**Labor remains tight for the oil & gas sector.** The oil & gas industry continues to face a shortage of skilled labor, with an unemployment rate that is ~3 percentage points below the overall US (see Exhibit 126). Attracting new talent remains a challenge, with oil & gas executives pointing to the cyclical nature of the industry and the impact of the energy transition on career longevity as the leading causes of labor tightness (see Exhibit 127). That said, increased automation within the oil & gas sector has the potential to drive greater efficiencies while simultaneously improving workforce safety.

**Exhibit 121:** Unemployment in the oil & gas sector remains low relative to the current US unemployment rate of 3.9%

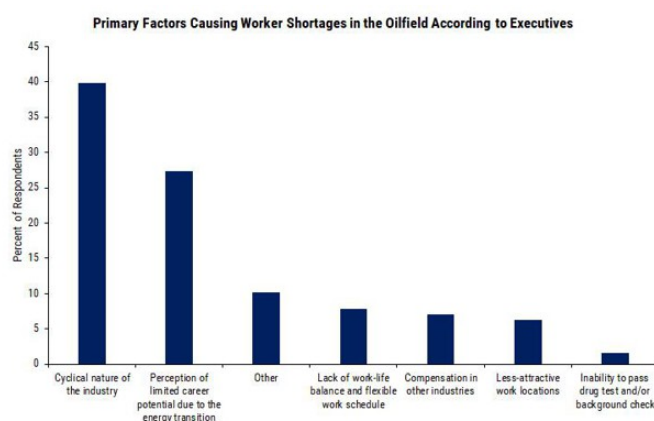


Source: Bureau of Labor Statistics/Haver Analytics

Companies have begun to embrace automation to increase efficiencies and improve worker safety. Key initiatives across our Energy coverage include:

- **Chevron Corporation (CVX):** In 2022, Chevron introduced Spot, a robotic canine built in partnership with Boston Dynamics capable of conducting environmental and safety monitoring, as well as emergency management (see [here](#)). Spot inspects plants to flag safety and equipment issues, increases efficiency by reducing the need for repetitive tasks, and gathers data in real time while keeping a log of observations for future use. In 2023, CVX increased its fleet of Spot robots and deployed them to its refineries in Pascagoula, Mississippi, and El Segundo, California. Currently, CVX has more Spot robots than any of its industry peers.

**Exhibit 122:** Oil & gas executives see the industry's cyclical nature and the energy transition as the leading causes for labor shortages



Source: Federal Reserve Bank of Dallas, Morgan Stanley Research. Note: Executives from 128 oil and gas firms answered this question during the survey collection period, March 15-23, 2023.

- **Imperial Oil (IMO):** In 2023, Imperial Oil completed the conversion of all its haul trucks to autonomous operation at the Kearl oil sands mine in northern Alberta. There are now 81 fully autonomous trucks in service, making IMO currently the largest operator of autonomous haul fleets in the world. The company expects the transition to self-driving trucks to boost mine productivity, reduce costs (~\$1/bbl savings), and improve safety.
- **Suncor Energy (SU):** At SU's Base Mine, the company plans to have 91 autonomous haul trucks in operation by the end of 2024. SU notes that autonomous trucks offer advantages over existing staffed trucks, including improved operational, environmental, and safety performance. The company estimates that upgrading the hauling fleet to fewer, bigger trucks and incorporating autonomous driving should result in a combined cost savings of C\$500 million per year.

**Exhibit 123:** Chevron's robotic canine, Spot

Source: Chevron Corporation

**Exhibit 124:** An operator uses Spot's CAM+IR capabilities to take visual and thermal images of equipment and gauges, which Chevron processes through its own computer vision program to detect anomalies

Source: Chevron Corporation, Boston Dynamics

**Exhibit 125:** Autonomous Haul System (AHS) driving on dirt road in North Steepbank Extension mine at Base Plant

Source: Suncor Energy

**Key Beneficiaries in our Energy Services Coverage:**

- **Global Diversified Energy Services & Equipment Majors**
  - **Baker Hughes (BKR):** Over the last several years BKR has increasingly introduced multiple new digital solutions and investments focusing on improving efficiency and performance while reducing emissions, helping to drive the long-term sustainability of customer operations. For example BKR introduced Leucipa into operations, a public and private cloud-based automated field production software solution designed to help oil and

gas operators proactively manage production and increase engineering efficiency. Notably, BKR has a robust partnership with c3.ai (AI) aimed at building, deploy and operating enterprise AI apps within O&G and industrial sectors. This partnership focuses on enabling customer adoption of scalable AI solutions that help promote safety, reliability, and sustainability, including conditions monitoring (BKR's Bentley Nevada business), emissions detection, predictive maintenance, and asset performance optimization.

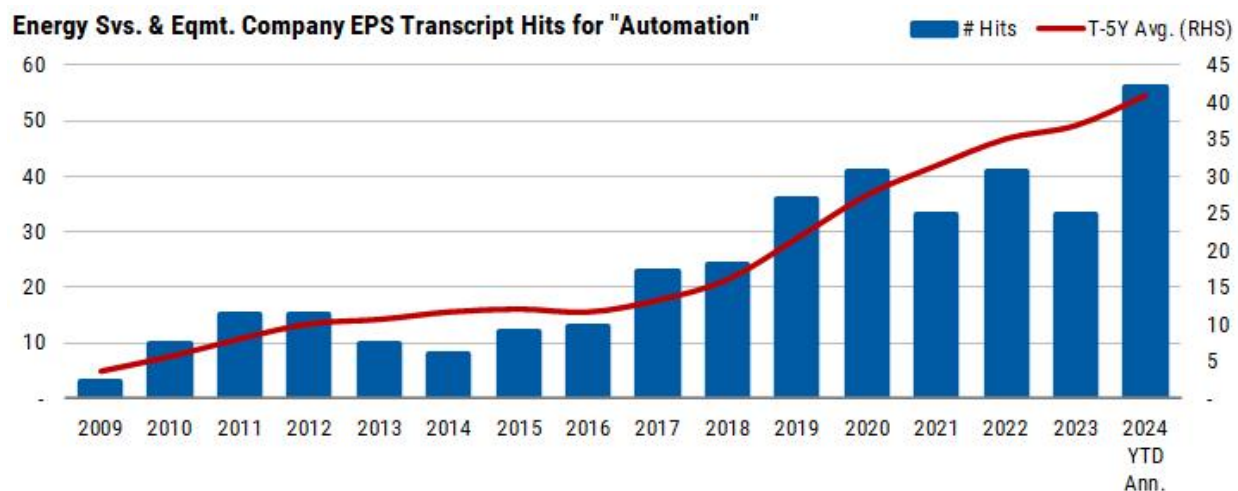


- **Halliburton Company (HAL):** One of HAL's key strategic priorities is "Accelerate Digital and Automation," which prioritizes being a leading software provider, automation of the value chain, and to drive internal efficiencies. For example, in November 2023, Halliburton and Sekal AS announced an agreement to jointly provide leading well construction automation solutions as part of a longer-term strategy to deliver fully automated drilling operations. Under the agreement, Halliburton and Sekal are collaborating on several technologies and services that incorporate Halliburton digitally integrated well construction solutions and the Sekal DrillTronics automation platform.
- **SLB NV (SLB):** Most recently, during SLB's 1Q24 earnings call, it reiterated its constructive view on digital adoption and commented that its proposed — "...ChampionX [acquisition] will only strengthen this production operation offering as it will complement and give us another platform to expand our digital adoption. So I remain very constructive. And I believe that it is long trend of digital adoption as we continue throughout the rest of the decade." Meanwhile, several years ago, SLB rolled out its DELFI AI platform in partnership with several leading global tech companies which provides SAAS, applications, and services to oil and gas and new energy customers (e.g., in late 2023, SLB launched a carbon storage screening and ranking solution). SLB's DELFI platform provides solutions to O&G customers aimed at enhancing efficiency and returns by integrating

its connected and autonomous drilling, data and AI solutions, and ~85+ of the top 100 global O&G companies are currently on SLB's DELFI platform.

- **Energy Equipment & Technology Suppliers — NOV Inc (NOV) and Tenaris (TS):** Energy equipment manufacturers are both suppliers and beneficiaries of automation technology — NOV and TS are utilizing automation and AI to drive more efficient and economic manufacturing operations, but are also key suppliers of automation technology for energy services and O&G producer customers in complex well development processes e.g., NOV's NOVOS™ drilling automation control system and ATOM™ RTX robotics solutions.
- **O&G Drillers — Helmerich & Payne (HP), Nabors (NBR), Patterson-UTI Energy (PTEN), and Transocean (RIG); and O&G Well Completions Services Providers — Profrac (ACDC) and Liberty Energy (LBRT):** Drilling contractors in our coverage (HP, NBR, PTEN, RIG) have been very front-footed in rolling out drilling automation solutions which are now generally categorically superior relative to human-only directed drilling operations. These automation solutions improve efficiencies, safety (e.g., removing people from the most dangerous areas on and around drilling rigs), and ultimately driving improved economic outcomes for customers and the drilling contractors. Drilling contractors and completions services providers (e.g., hydraulic fracturing contractors — ACDC, LBRT, PTEN) are also employing AI and digital solutions to optimize well designs aimed at maximizing well productivity and minimizing costs.

**Exhibit 126:** Discussions about automation in companies under our energy services coverage have increased by 56% since 2019



Source: Morgan Stanley Research, AlphaSense

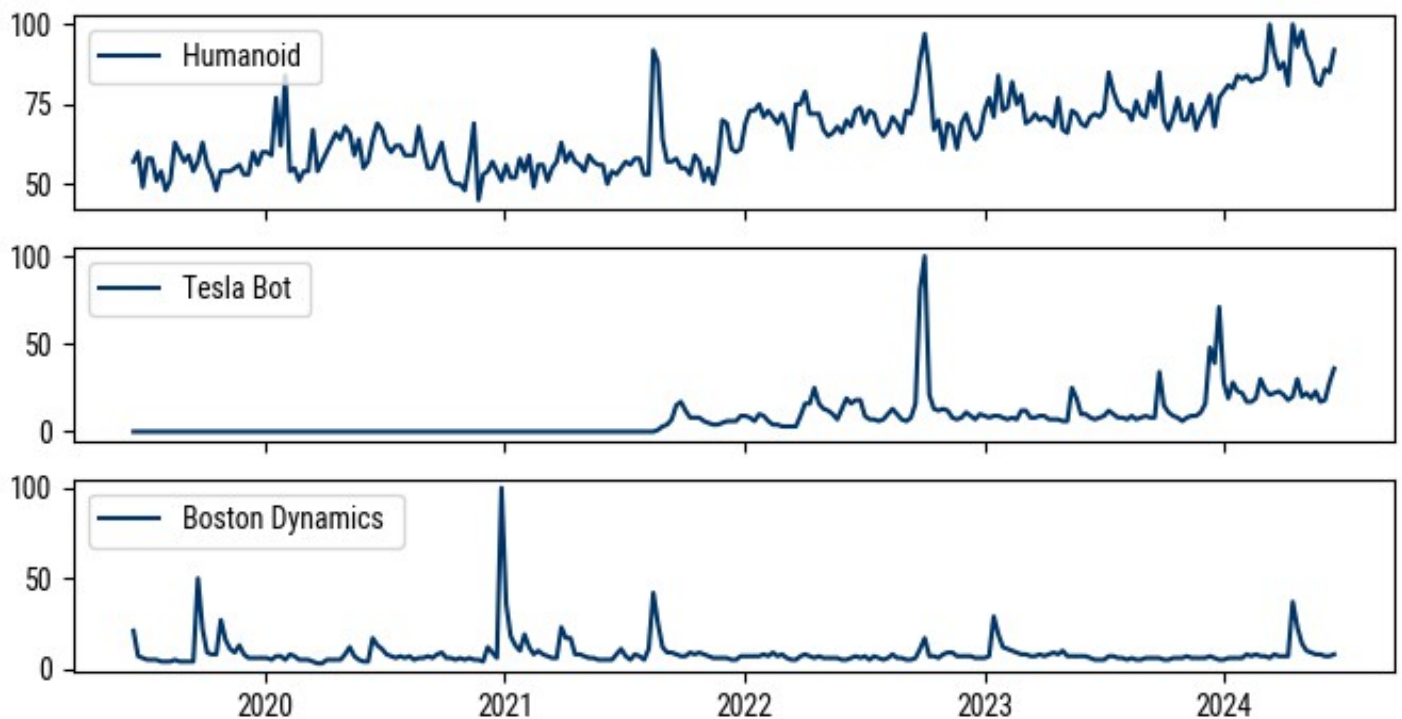
# Humanoid Robotics and Capital Formation

**Cybernetic collective robotic learning.** Imagine for a moment a humanoid robot standing in front of a kitchen island on which an onion sits on a small plate next to a paring knife. Now imagine a large warehouse with 1,000 humanoid robots each standing next to a kitchen island with the onion on a plate next to a knife. The robots have watched many thousands of hours of videos of chefs peeling onions both live and through video. They have accumulated knowledge of the nature and structure of onions and how knives are used to peel them. Now imagine a simple verbal instruction is given to this army of robots: "Please skin the onion in front of you and set it on the plate when finished." All 1,000 robots go to work... slowly and clumsily at first. Most struggle to grasp the onion at all. Others grasp the onion but drop the plate. A few of the better ones grasp the onion, don't disturb the plate but fumble with the knife. As each trial and error accumulates among the group, the entire population learns at the collective rate of the best robot at any point in time. The aggregated learning of the cybernetic collective "spools up" to achieve an accelerated frontier of group learning. When the physical practice is completed with a "winning" robot having peeled its onion better than the other 999, best practices can then be shared and further improved through hundreds of millions of trials among their digital twins in a simulated 'Omniverse.'

sily at first. Most struggle to grasp the onion at all. Others grasp the onion but drop the plate. A few of the better ones grasp the onion, don't disturb the plate but fumble with the knife. As each trial and error accumulates among the group, the entire population learns at the collective rate of the best robot at any point in time. The aggregated learning of the cybernetic collective "spools up" to achieve an accelerated frontier of group learning. When the physical practice is completed with a "winning" robot having peeled its onion better than the other 999, best practices can then be shared and further improved through hundreds of millions of trials among their digital twins in a simulated 'Omniverse.'

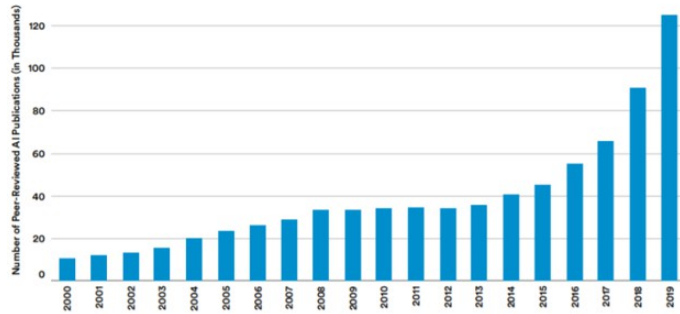
**In this section, we explore the accelerating public and private interest in humanoid robotics, as well as new capital formation.**

**Exhibit 127:** Search Activity for Robots & Tools



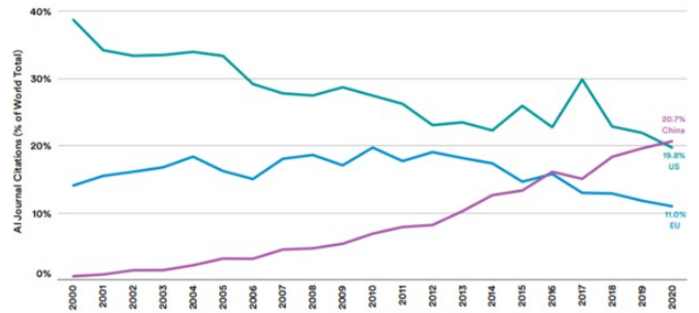
Source: Google Trends, Morgan Stanley Research

**Exhibit 128:** Domestic AI & Robotics academic publications



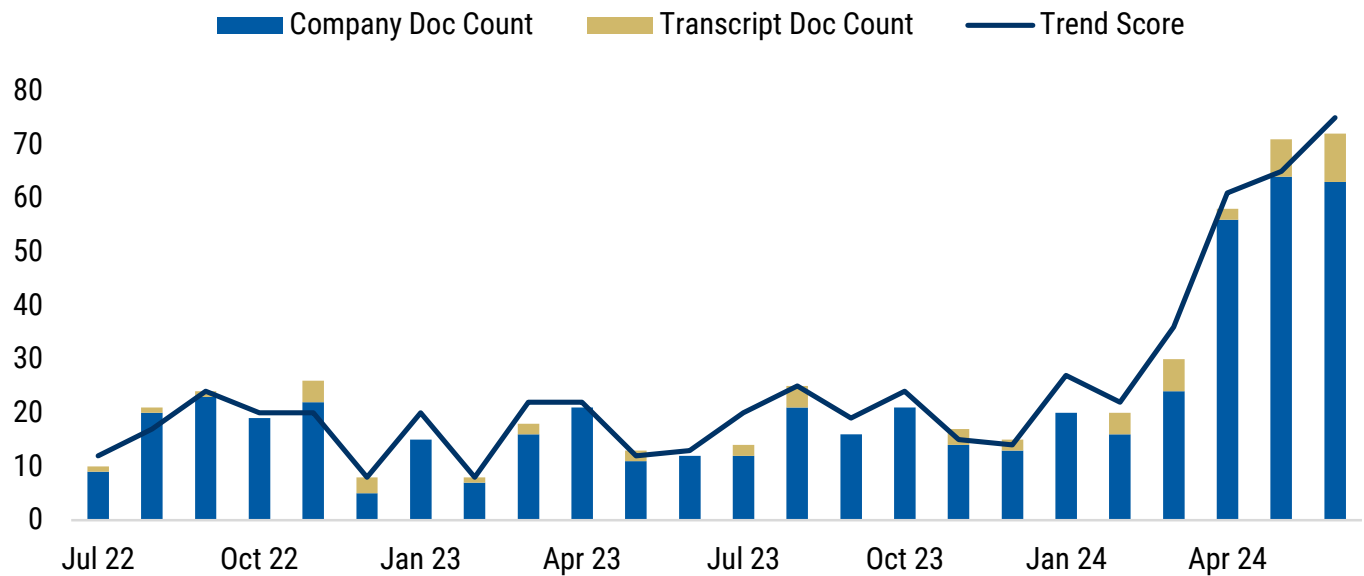
Source: Elsevier, Stanford, MS Research

**Exhibit 129:** AI in robotics citations by region over time



Source: Microsoft Academic, Stanford, Morgan Stanley Research

**Exhibit 130:** 'Humanoid' Mentions in Public Company Transcripts (conferences and earnings calls)



Source: Alphasense, Morgan Stanley Research

## Robotics Gaining Momentum in the Venture Capital Community

Open-source robotics models now make up >3% of those available for download, up from <1% a year ago. Bucking the wider VC trend, robotics are seeing an inflection: fewer, larger deals. Most important, though, over the long term could be the rising focus by Middle East nations.

Even before [NVIDIA's keynote speech](#) in March 2024 — which left little to the imagination about the company's intentions for the embodiment of AI — robotics were a recurring AI sub-theme, particu-

larly at the Morgan Stanley TMT Conference earlier in March. After a number of false starts, venture investors and companies are betting that this time may be different for robotics and embodied AI. NVIDIA released a new general-purpose foundational AI model called [GROOT](#), designed specifically for advancing breakthroughs in humanoid robotics. We first discussed humanoids in the [Moonshots](#) report from 2022, but the time horizon has since accelerated materially.

**Exhibit 131:** NVIDIA display of humanoid robots at GTC



Source: NVIDIA GTC (GPU Technology Conference)

This topic has come to life in the past month with a growing number of announcements in the field, most notably from Figure AI, which has a partnership with OpenAI and agreements with BMW for its US assembly plant. Similarly, Mercedes-Benz announced its intention to automate low-skilled and physically challenging repetitive tasks with a collaboration with Apptikon's Apollo robot.

**Exhibit 132:** NVIDIA display of humanoid robots at GTC

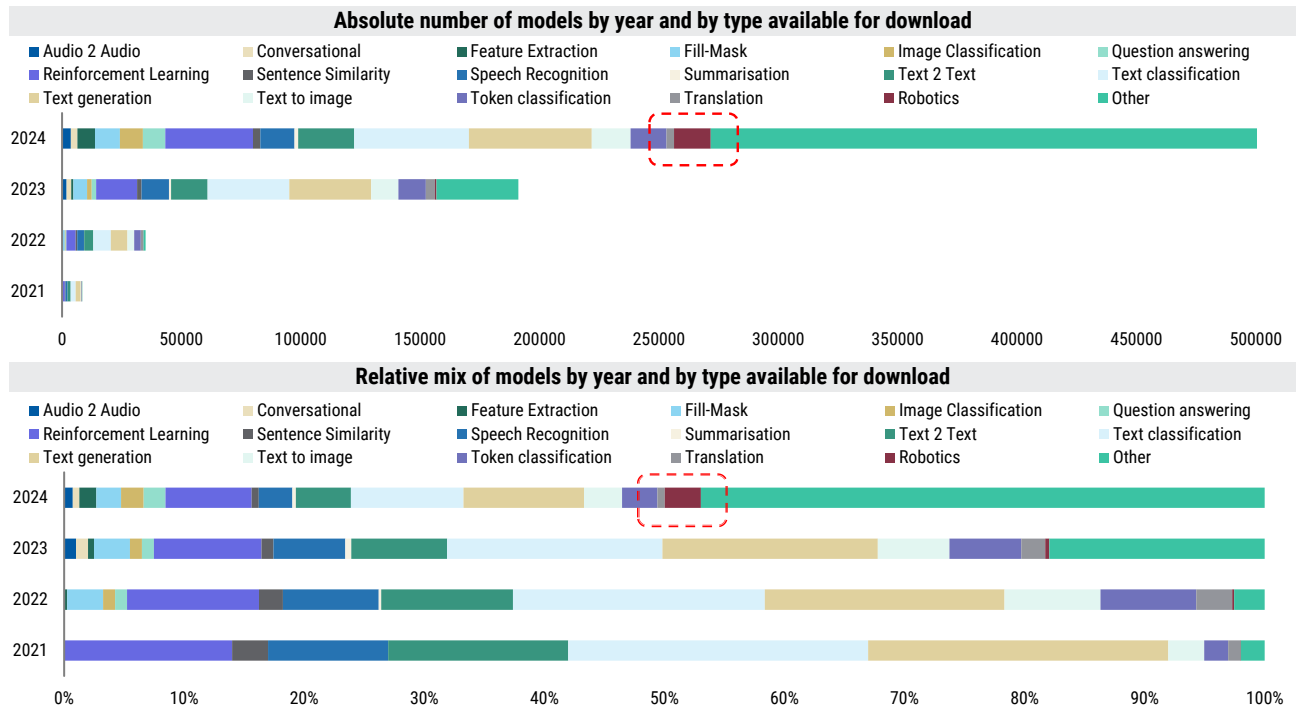


Source: Youtube, Figure AI

Looking beneath the surface, the experimentation by enterprise and research laboratories in this field of robotics machine/vision learning has been gathering pace. GROOT is far from the only model in the field of robotics R&D. By exploring the open-source model repository held by Hugging Face, we can quickly see the growing importance of this field of research. Open-source robotics models barely existed in

large volume even a year ago. While still now only 3% of models are available to be downloaded, and typically not ranking in the top 10 most frequently downloaded yet, they are nonetheless taking share in a rising market. The entire ecosystem is still growing, but robotics' relative share gain has been coming at the expense of conversational, text generation and image classification models.

Exhibit 133: Open-source models listed for download by specialism



Source: Hugging Face, Morgan Stanley Research

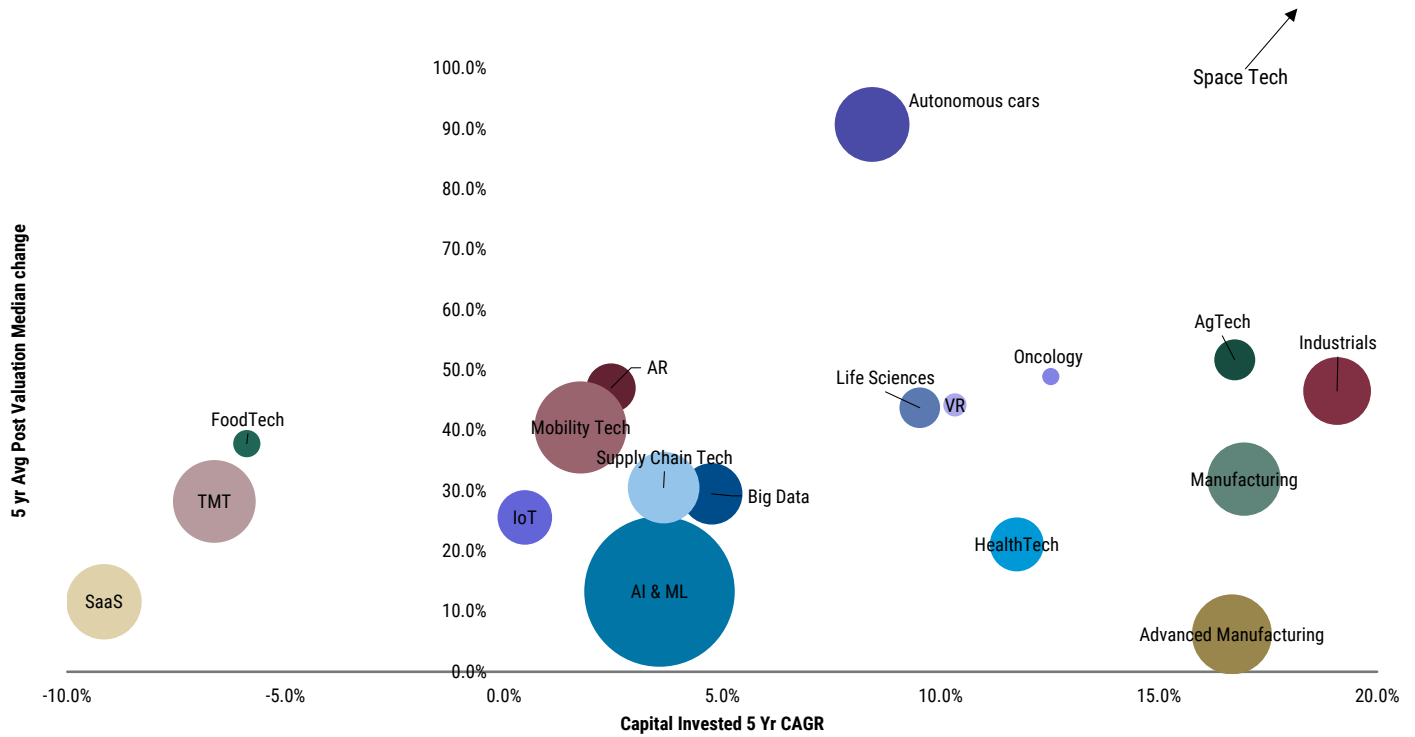
Turning to the venture ecosystem, the robotics investment landscape looks markedly different to most other verticals. First, there is growth; second, valuations are still expanding whereas many of the private markets have seen a compression in post-money valuations.

“ You just can't differentiate between a robot and the very best of humans. ”

*I, Robot, Isaac Asimov*

Certain end markets — such as food preparation robotics — have disappointed investors. Zume was a company that raised over \$400 million to create robot-made pizzas. It has since shut down. Similarly, there has been more disappointment than positive news flow in the electric/ autonomous driving sub-vertical in recent months. However, in aggregate, the amount of capital being deployed into nearly all verticals of the robotics industry is on the rise. The largest growth other than in space applications (which remains small) has been in industrial and manufacturing use cases. This too was on display in the NVIDIA keynote speech recently, showing the benefits of using the company's Omniverse platform as a means of testing factory layouts in rigorous detail before even having to place any orders to gain maximum plant efficiency.

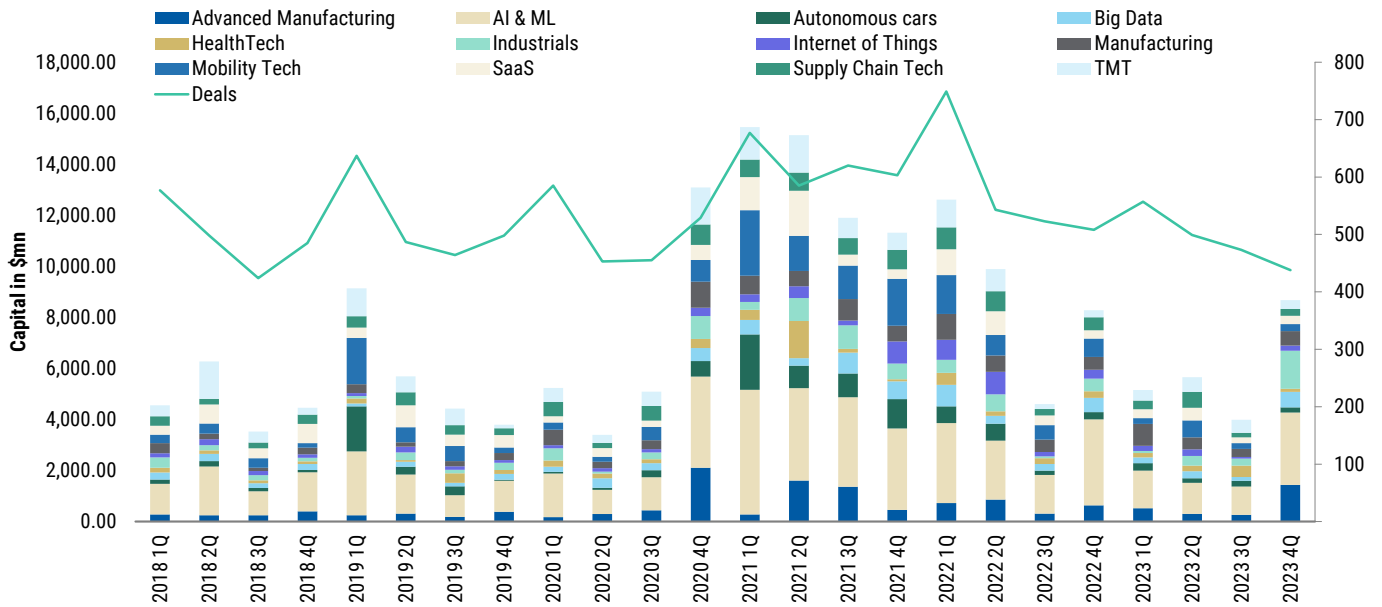
Exhibit 134: Robotics sub-vertical investments and valuation change



Source: Pitchbook, Morgan Stanley Research

Even though robotics continues to see fewer deals executed — much like the rest of the venture industry — this is in contrast to capital deployment increasing by more than 2x QoQ in the final period of 2023.

Exhibit 135: Capital invested in robotics sub-verticals over time

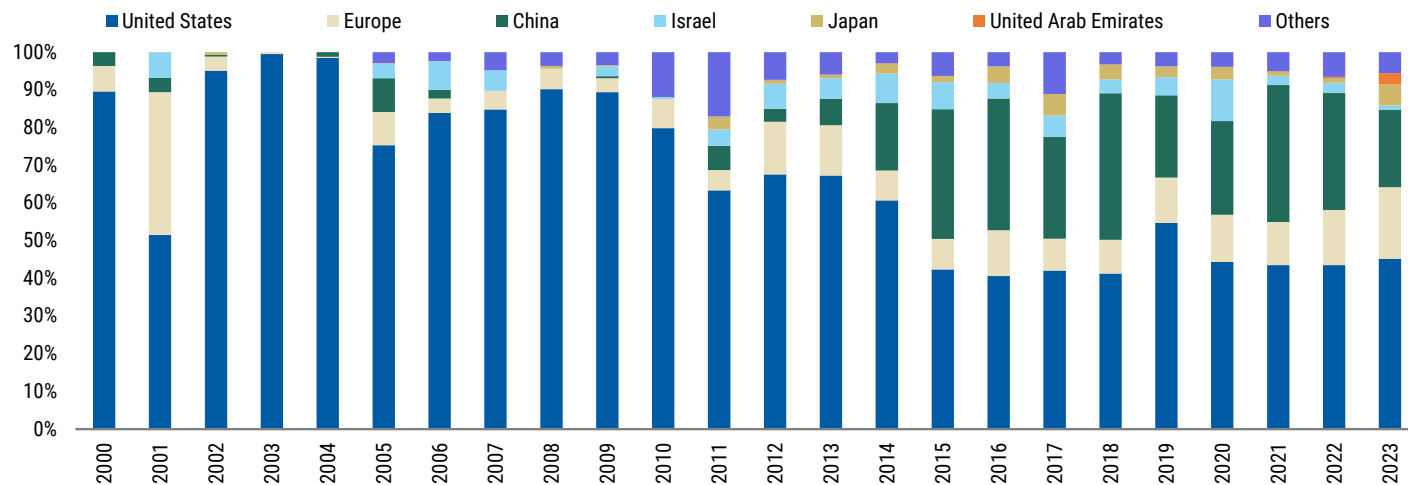


Source: Pitchbook, Morgan Stanley Research



In many regards, there is nothing new here. Boston Dynamics was founded in 1992 and was later valued at \$1.1 billion in 2020 in a majority acquisition funding round. However, the lion's share of research and funding was historically particularly focused on US companies. This has since widened out with a growing portion of funding typically being allocated to Chinese start-ups. As this proportion of funding has pulled back in recent quarters, other nations have been vying for investment. Japan, the UAE and other Middle Eastern companies are capturing this inflection in the flow of capital to robotics start-ups.

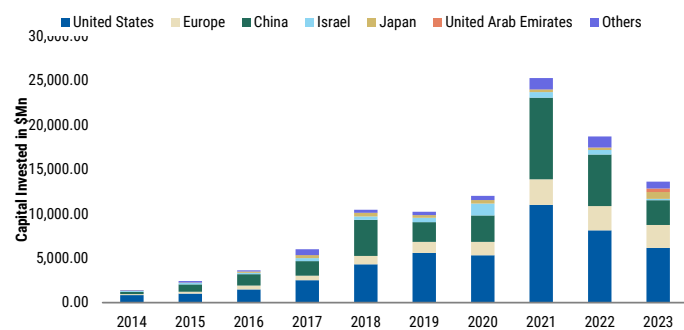
**Exhibit 136:** Total capital invested in robotics by country



Source: Pitchbook, Morgan Stanley Research

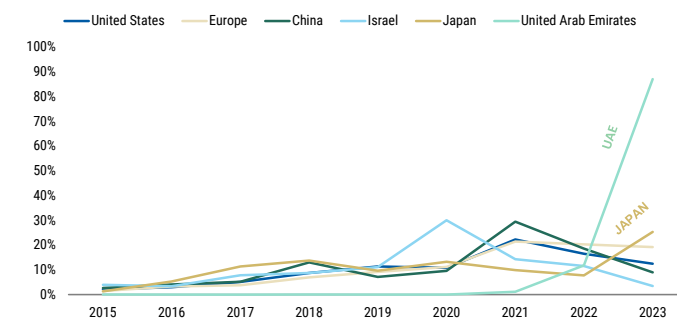
It is unwise to extrapolate data points too far too quickly. However, what sets the UAE apart is that the vast majority of funding for its domestic robotics start-ups is coming from local rather than international sources. This typically occurs when governments are incentivizing local investment in critical infrastructure on an accelerated time horizon — see Israel's investment and dominance in cyber-security start-ups. With recent news flow describing a \$40 billion AI fund for Saudi Arabia, we expect that this type of regional mix shift will continue — particularly given the strategic national importance that robotics and AI will have over the coming decades.

**Exhibit 137:** Total capital invested in robotics by country



Source: Pitchbook, Morgan Stanley Research

**Exhibit 138:** Countries with % of own capital deployed in robotics by year



Source: Pitchbook, Morgan Stanley Research

# Humanoid Competitive Landscape

Exhibit 139: Summary of Robotics Companies

## Humanoid Robot Company Overviews

Company	Founded	Country	Primary Focus	Stage	Humanoid Robot	Notable Customers/Partners/Test Cases	Notable Financial Backers
IX	2014	Norway	Robotics	Series B	EVE; NEO	Everon, Sunnaas Hospital (Norway)	Tiger Global, NVIDIA, EQT Ventures, OpenAI
AGILITY ROBOTICS	2015	USA	Robotics	Series B	Digit	Amazon	Amazon, DCVC, Playground Global, The Robotics Hub
APPTPONIK	2016	USA	Robotics	Seed	Apollo, Astra	Mercedes Benz, NASA, GXO Logistics	NASA, Teres, Perot Jain, Capital Factory
Boston Dynamics	1992	USA	Robotics	Private	Atlas		
Figure	2018	USA	Robotics	Series D	Figure 01	BMW	Microsoft, OpenAI, NVIDIA, Jeff Bezos, Intel, ARK Invest
Fourier Intelligence	2015	China	Robotics	Series D	GR-1		Softbank, Prosperity7, Vision Plus Capital, Quanghai Fund of Funds
HONDA	1948	Japan	Automotive	Public Company	ASIMO		
mentee robotics	2022	Israel	Robotics	Seed	Menteebot		Ahren Innovation, Hookipa AG, Doron Sagie
NAVER	1999	South Korea	Internet	Public Company	AMBIDEX		
SANCTUARY AI	2018	Canada	Robotics	Series A	Phoenix	Magna International	Canadian SIF, Bell Canada, Verizon Ventures, Accenture, Magna
TESLA	2003	USA	Automotive	Public Company	Optimus		
TOYOTA	1937	Japan	Automotive	Public Company	T-HR3 / Punyo		
UBTECH	2012	China	Robotics	Public Company	Walker; Walker S	NIO, Dongfeng Motor	
UnitreeRobotics®	2016	China	Robotics	Series B	H-1, G-1		Meituan, CITIC Securities, Winreal Investment, Source Code Capital
XIAOMI	2010	China	Consumer Electronics	Public Company	CyberOne		
XPENG	2014	China	Automotive	Public Company	PX5		

Note: Notable customers/partners shown if disclosed. Many do not disclose customers/partners.









Source: Company Data, Crunchbase, Morgan Stanley Research

Exhibit 140: Summary of Humanoid Robots

Robot Name	NEO	Digit	Apollo	Atlas	Figure 01	GR-1	ASIMO	Menteebot
Company Name	1X Technologies	Agility Robotics	Apptроник	Boston Dynamics	Figure	Fourier Intelligence	Honda	Mentee Robotics
Picture								
Year Revealed	2023	2022	2023	2013	2023	2023	2000	2024
Primary Purpose	General	Industrial/Logistics	Industrial/Logistics	Industrial/Logistics	Industrial/Logistics	Healthcare	Research Platform	General
Status	Prototype	Prototype	Prototype	Prototype	Prototype	In Production	Retired	Prototype
Height	5' 5"	5' 9"	5' 8"		5' 6"	5' 4"	4' 3"	5' 9"
Weight	66 lbs	99 lbs	160 lbs		132 lbs	121 lbs	106 lbs	154 lbs
Maximum Speed	2.5 - 7.5 mph	3.4 mph			2.7 mph	3.0 mph	1.7 mph	3.4 mph
Carrying Capacity	44 lbs	35 lbs	55 lbs		44 lbs	110 lbs		55 lbs
Battery Life	2 - 4 Hours	2.25 Hours	4 Hours		5 Hours		1 Hour	5 Hours
Degrees of Freedom	55	16			41	54	57	40
AI Partners	NVIDIA, OpenAI	NVIDIA	NVIDIA	NVIDIA	NVIDIA, OpenAI	NVIDIA		
Customers/Testers	Everon	Amazon	Mercedes Benz, GXO		BMW			
Key								
Overview	Dimensions	Capabilities	Partners					

Source: Company Data, Crunchbase, Morgan Stanley Research

Exhibit 141: Summary of Humanoid Robots (Continued)

Robot Name	AMBIDEX	Phoenix	T-HR3 / Purno	Optimus	Walker Series	G-1	CyberOne	PX5
Company Name	Naver Labs	Sanctuary AI	Toyota	Tesla	UBTECH	Unitree	Xiaomi	XPENG
Picture								
Year Revealed	2019	2023	2017	2022	2018	2024	2022	2023
Primary Purpose	Service/Leisure	General	General Use	Industrial/Logistics	General	General	Service/Leisure	Industrial/Logistics
Status	Prototype	Prototype	Prototype	Prototype	In Production	In Production	Prototype	Prototype
Height		5' 7"	5' 1"	5' 8"		4' 2"	5' 10"	4' 11"
Weight		155 lbs	165 lbs	160 lbs		77 lbs	115 lbs	
Maximum Speed		3.0 mph		5.0 mph		4.5 mph		
Carrying Capacity		55 lbs		45 lbs		7 lbs	3 lbs	7 lbs
Battery Life						2 Hours		
Degrees of Freedom		75	32	50		43	21	
AI Partners		NVIDIA			Baidu	NVIDIA		NVIDIA
Partners/Testers		Magna			NIO, Dongfeng			
Key								
Overview	Dimensions	Capabilities	Partners					

Source: Company Data, Crunchbase, Morgan Stanley Research




“ We aren’t dealing with ordinary machines here... In some cases, they have been designed by other computers. We don’t know exactly how they work. ”

Chief Supervisor, *Westworld*

## Robotics Company Profiles

**1X Technologies (EVE/NEO):** 1X is a Norwegian robotics startup developing general purpose humanoid robots intended to perform labor alongside humans. Founded in 2014 originally as "Halodi Robotics," the company had its first major commercial breakthrough in 2020 when it partnered with Everon by ADT Commercial to deploy 150-250 of its first generation, wheeled humanoid 'EVE' in night guarding roles in US commercial buildings. Since then, 1X has raised capital from notable investors including Tiger Global, Open AI, and EQT ventures to develop its next generation, legged humanoid 'NEO'.



Exhibit 142: 1X Technologies – Company Overview

 <b>1X Technologies</b>	
Humanoid Robots	Company Profile
 <p><b>EVE</b></p>	 <p><b>NEO</b></p>
	<p><b><u>Founded</u></b> 2014</p> <p><b><u>Headquarters</u></b> Moss, Norway</p> <p><b><u>Robot Purpose</u></b> General Use Industrial/Logistics Healthcare</p> <p><b><u>Description</u></b> Developing EVE (wheeled) and NEO (legged) robots for commercial and general applications</p>
	<p><b><u>Total Raised</u></b> \$136.5 Mn</p> <p><b><u>Startup Stage</u></b> Series B</p> <p><b><u>Notable Backers</u></b> Tiger Global EQT Ventures NVIDIA OpenAI</p>

Source: 1X Technologies, Crunchbase, Morgan Stanley Research

**Agility Robotics (Digit):** Agility is an American robotics startup developing its humanoid robot "Digit" primarily for pick-and-place applications in industrial and logistics settings. The robot uniquely has telescopic, bird-like legs to crouch or reach to grab objects and move them to a specified location. While seeming simple, pick-and-place is a historically low-skill, labor-intensive task that can be automated relatively-easily allowing humans to focus on higher-value work. Agility is partnered with and partially backed by Amazon, with the company announcing in October 2023 that it would [begin testing](#) a Digit fleet at its Seattle R&D facility.




Exhibit 143:Agility Robotics – Company Overview

 <b>Agility Robotics</b>	
Humanoid Robots	Company Profile
 <p style="text-align: center;"><b>Digit</b></p>	<p><b><u>Founded</u></b> 2015</p> <p><b><u>Headquarters</u></b> Albany, Oregon</p> <p><b><u>Robot Purpose</u></b> Industrial/Logistics</p> <p><b><u>Description:</u></b> Developing Digit, a robot with bird-like legs for logistics and other commercial purposes</p> <p><b><u>Total Raised</u></b> \$178.8 Mn</p> <p><b><u>Startup Stage</u></b> Series B</p> <p><b><u>Notable Backers</u></b> Amazon DCVC Playground Global The Robotics Hub</p>

Source: Agility Robotics, Crunchbase, Morgan Stanley Research

**Appronik (Apollo):** Appronik is an American robotics startup spun out of the University of Texas at Austin in 2016. Appronik's most notable partnership is with NASA. Collaboration began in 2013, when the company worked to develop NASA's Valkyrie robot, and the partnership was expanded in 2022 to accelerate development of Appronik's latest humanoid robot, "Apollo," for industrial, retail, and other general-purpose applications. Later in March 2024, Appronik announced that Mercedes-Benz would begin piloting Apollo at its manufacturing plants to explore potential use cases on the production line. Then, in June 2024, Appronik announced a partnership with GXO to test the Apollo robot for warehouse use.

Exhibit 144: Appronik – Company Overview




 <b>Appronik</b>	
Humanoid Robots	Company Profile
    <b>Apollo</b>	<p><b><u>Founded</u></b> 2016</p> <p><b><u>Headquarters</u></b> Austin, Texas</p> <p><b><u>Robot Purpose</u></b> Industrial/Logistics General Use</p> <p><b><u>Description:</u></b> Developing Apollo based on knowledge from previous work on NASA Valkyrie</p> <p><b><u>Total Raised</u></b> \$28.7 Mn</p> <p><b><u>Startup Stage</u></b> Seed</p> <p><b><u>Notable Backers</u></b> NASA Terex Perot Jain Capital Factory</p>

Source: Appronik, Crunchbase, Morgan Stanley Research



**Boston Dynamics:** Boston Dynamics is a spin-off from MIT's Leg Laboratory and has been creating robot technologies since the early 1990s. Its hydraulic-powered humanoid robot, "Atlas," was launched in 2013 and gradually refined for over decade until its eventual replacement in 2024 with an [all-new electric powered version](#). Since its launch, Atlas continued to gather viral internet attention, often accumulating 10's of millions of views on YouTube. For example, in 2019, the company posted Atlas achieving [this gymnastic display](#) which circulated on social media, gathering close to 17mn views. It showcased the ability to run, jump, backflip, and rebalance itself using multiple limbs simultaneously. At the time, the demonstration cemented the company's lead in dextrous robotics.


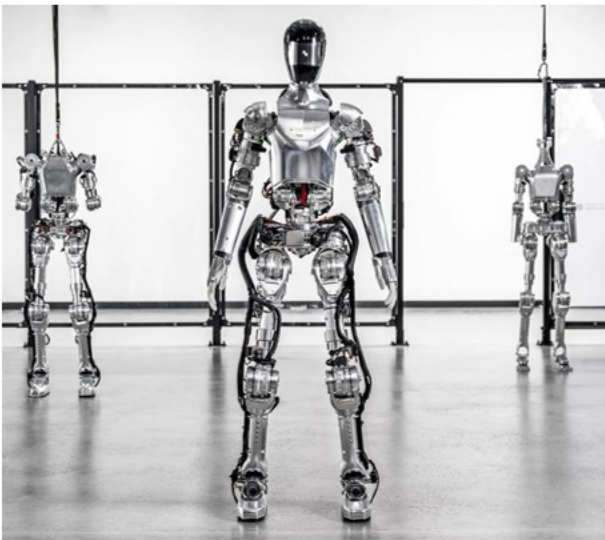
**Exhibit 145:** Boston Dynamics – Company Overview

 <span style="font-size: 1.2em; font-weight: bold; margin-left: 10px;">Boston Dynamics</span>	
Humanoid Robots	Company Profile
<div style="text-align: center;">  <p style="font-weight: bold; margin-top: 10px;">Atlas (Hydraulic)</p> </div>	<div style="text-align: center;">  <p style="font-weight: bold; margin-top: 10px;">Atlas (Electric)</p> </div> <div style="margin-top: 20px;"> <p><b><u>Founded</u></b> 1992</p> <p><b><u>Headquarters</u></b> Waltham, Massachusetts</p> <p><b><u>Robot Purpose</u></b> General Use Industrial/Logistics Safety &amp; Response</p> <p><b><u>Description:</u></b> A spin-off from MIT developing Atlas, a humanoid robot originally designed with assistance from DARPA and the US Government</p> </div>

Source: Boston Dynamics, Crunchbase, Morgan Stanley Research

**Figure AI (Figure 01):** Figure is an American robotics startup founded by Brett Adcock, a co-founder of Archer Aviation, a publicly traded eVTOL company. Since 2018, it has been developing the Figure 01, an AI-powered, general-purpose humanoid robot designed to replace or assist with a wide range of human tasks. The company is one of the most well-funded robotics startups globally, having raised nearly \$1 billion from notable backers including Microsoft, OpenAI, NVIDIA, and Jeff Bezos. Additionally, through its relationship with OpenAI, Figure is using the company's AI language model to power [speech-to-speech reasoning and visual/language intelligence](#), enabling the robot to receive commands from and interact with humans. In Jan. 2024, Figure announced its first major commercial agreement with BMW to find use-cases in automotive production, with staged deployment beginning at BMW's Spartanburg, South Carolina, plant.



**Exhibit 146:** Figure — Company Overview

 <b>Figure AI</b>	
Humanoid Robots	Company Profile
	<p><b><u>Founded</u></b> 2018</p> <p><b><u>Headquarters</u></b> San Francisco, California</p> <p><b><u>Robot Purpose</u></b> Industrial/Logistics General Use</p> <p><b><u>Description:</u></b> Developing general purpose humanoid robots in cooperation with OpenAI</p>
<b>Figure 01</b>	<p><b><u>Total Raised</u></b> \$854 Mn</p> <p><b><u>Startup Stage</u></b> Series D</p> <p><b><u>Notable Backers</u></b> Microsoft OpenAI NVIDIA Jeff Bezos Intel ARK Invest</p>

Source: Figure, Crunchbase, Morgan Stanley Research

**Fourier Intelligence (GR-1):** Fourier Intelligence is a Chinese healthcare technology and robotics startup developing a wide-range of products primarily related to nursing and rehabilitation. In mid-2023, the company launched its general-purpose humanoid robot the **GR-1**, attracting attention for its sleek design and quick time to market, becoming one of the first humanoid robots to achieve mass production and delivery. Potential applications include not just healthcare, but also industrial/logistics, household service, and security inspection among others.



**Exhibit 147:** Fourier Intelligence – Company Overview

 <b>Fourier Intelligence</b>	
Humanoid Robots	Company Profile
 <p style="text-align: center;"><b>GR-1</b></p>	<p><b><u>Founded</u></b> 2015</p> <p><b><u>Headquarters</u></b> Shanghai, China</p> <p><b><u>Robot Purpose</u></b> Healthcare Industrial/Logistics General Use</p> <p><b><u>Description:</u></b> Developing the GR-1, and one of the first humanoid robots to reach mass production</p> <p><b><u>Total Raised</u></b> CN¥ 638 Mn</p> <p><b><u>Startup Stage</u></b> Series D</p> <p><b><u>Notable Backers</u></b> SoftBank Prosperity7 Vision Plus Capital Qianhai FoF</p>

Source: Fourier Intelligence, Crunchbase, Morgan Stanley Research

**Honda (ASIMO):** Honda was one of the first major corporations to develop humanoid technology, having done so since the 1980s. In 2000, Honda introduced ASIMO (Advanced Step in Innovative Mobility). While never intended for significant commercial use, ASIMO was a showcase of all the achievements Honda had made in humanoid technology to date. The robot underwent over a decade of refinement, often making public appearances displaying its capabilities. For example, in 2009, a video of ASIMO [conducting the Detroit Orchestra](#) went viral on Youtube, and later, in 2014, ASIMO was shown [playing soccer](#) with then US President Barack Obama. While the ASIMO project was retired by Honda in 2018, we wanted to highlight it in this report given the impact ASIMO had in generating global excitement for the possibilities of humanoid robots and inspiring later innovation. We also do not rule out that Honda could re-start its humanoid development given the progress it has made in the past.

**Exhibit 148:** Honda – Company Overview

 <b>Honda</b>		
Humanoid Robots	Company Profile	
 <p><b>ASIMO</b></p>	<p><b><u>Founded</u></b> 1948</p>	<p><b><u>Stock Ticker</u></b> 7267-JP</p>
	<p><b><u>Headquarters</u></b> Tokyo, Japan</p>	<p><b><u>Market Cap</u></b> \$52.2 bn</p>
	<p><b><u>Robot Purpose</u></b> Research Platform</p>	
	<p><b><u>Description:</u></b> Had been developing humanoids since the 1980's, eventually resulting with ASIMO, used primarily to showcase the possibilities of humanoid</p>	

Note: Market capitalization as of 6/18/2024.

Source: Honda, FactSet, Morgan Stanley Research

**Mentee Robotics (Menteebot):** Mentee Robotics is an Israeli startup created by Prof. Amnon Shashua, the founder of Mobileye Global. The company is developing **Menteebot**, a general-purpose humanoid robot designed to act both as a domestic assistant within households and an automation tool within a warehouse. Notably, the company is investing in vertical integration with self-made actuators, sensors, drivers, and electronics. As for training, Menteebot utilizes "Advanced Sim2Real" transformation that allows the robot to train through reinforcement learning in a simulated environment rather than in the physical world. Like other robotics startups, the company is also integrating its robot with large-language-models to enable the robot to take verbal orders from a human operator.

**Exhibit 149:** Mentee Robotics – Company Overview



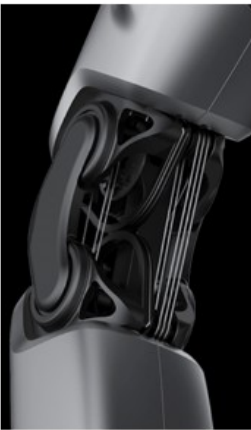
Mentee Robotics		
Humanoid Robots	Company Profile	
 <p><b>Menteebot</b></p>	<p><b><u>Founded</u></b> 2022</p>	<p><b><u>Total Raised</u></b> \$17 Mn</p>
	<p><b><u>Headquarters</u></b> Herzliya, Israel</p>	<p><b><u>Startup Stage</u></b> Seed</p>
	<p><b><u>Robot Purpose</u></b> General Use Industrial/Logistics Service/Leisure</p>	<p><b><u>Notable Backers</u></b> Ahren Innovation Hookipa AG Doron Sagie</p>
	<p><b><u>Description:</u></b> Started by the founder of AV technology company, Mobileye. Developing Menteebot, a humanoid AI bot designed to be mentored.</p>	

Source: Mentee Robotics, Morgan Stanley Research



**Naver Labs (AMBIDEX):** Naver Labs is a subsidiary of Naver Corporation, a publicly traded Korean internet company. The company is developing a variety of robotics and AI applications including robotaxis, wheeled robots, and most recently, a humanoid robot called "AMBIDEX." AMBIDEX is unique in that it uses a cable-driven mechanism to power its movement. Most humanoids utilize high-powered motors and actuators to enable heavy-load work. However, these could be considered dangerous when interacting with humans, particularly in the home. By mimicking human motion through a cable mechanism designed around muscles and tendons, AMBIDEX is able to interact naturally and safely with humans while achieving a similar level of precision and control as industrial robots.

**Exhibit 150:** Naver Labs – Company Overview


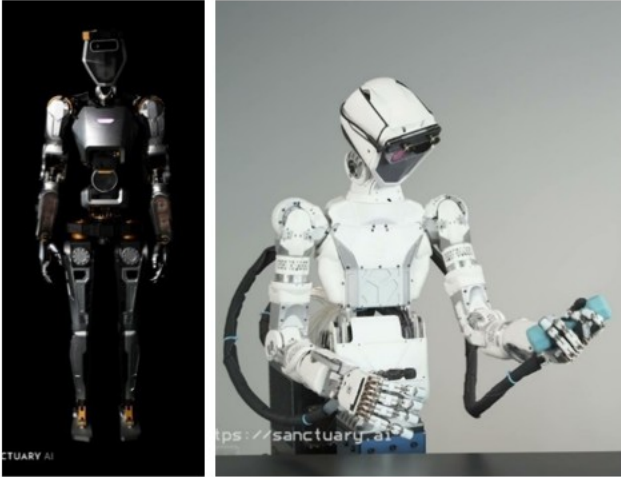
 <b>Naver Labs</b>	
Humanoid Robots	Company Profile
  <b>AMBIDEX</b>	<p><b><u>Founded</u></b> 1999</p> <p><b><u>Stock Ticker</u></b> 035420-KR</p> <p><b><u>Headquarters</u></b> Seongnam, South Korea</p> <p><b><u>Market Cap</u></b> \$18.1 bn</p> <p><b><u>Robot Purpose</u></b> Service/Leisure General Use</p> <p><b><u>Description:</u></b> Subsidiary of Naver, a leading Korean internet company. Developing AMBIDEX, a humanoid that uses cables to manipulate its limbs similar to human muscles/tendons.</p>

Source: Naver, FactSet, Morgan Stanley Research



**Sanctuary AI (Phoenix):** Sanctuary is a Canadian startup seeking to create a safe place (hence the name Sanctuary) for collaboration on robots able to conduct human-like tasks in a safe way. With its general-purpose humanoid robot, "Phoenix," Sanctuary intends to create a robot that displays human-like intelligence, taking the burden off of the human workforce while being either directly piloted or supervised by humans. In April 2024, the company announced a [partnership with Magna International](#), one of the largest automotive suppliers in the world, to eventually equip Magna's manufacturing facilities with its robots.


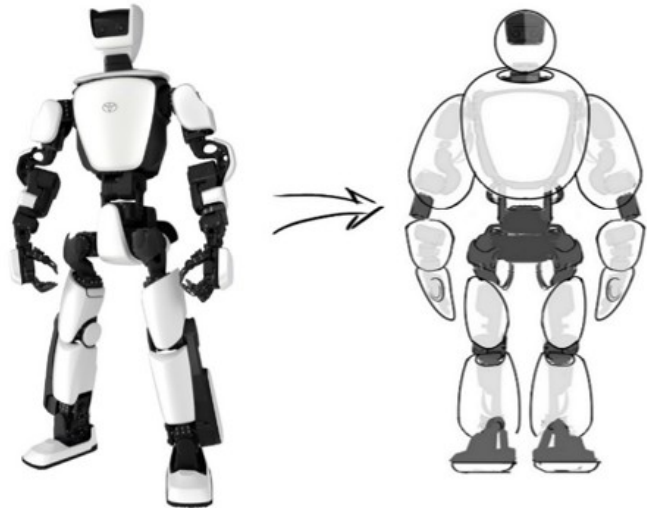
Exhibit 151: Sanctuary AI – Company Overview

 <b>Sanctuary AI</b>	
Humanoid Robots	Company Profile
 <p style="text-align: center;"><b>Phoenix</b></p>	<p><b><u>Founded</u></b> 2018</p> <p><b><u>Headquarters</u></b> Vancouver, Canada</p> <p><b><u>Robot Purpose</u></b> General Use Industrial/Logistics</p> <p><b><u>Description:</u></b> Developing Phoenix, a humanoid robot designed to safely co-interact with humans</p> <p><b><u>Total Raised</u></b> \$89.7 Mn</p> <p><b><u>Startup Stage</u></b> Series A</p> <p><b><u>Notable Backers</u></b> Canadian SIF Bell Canada Verizon Ventures Accenture</p>

Source: Sanctuary AI, Crunchbase, Morgan Stanley Research

**Toyota (T-HR3):** In 2017, Toyota launched "T-HR3" as a humanoid robot capable of mimicking the movements of a remote human operator. With T-HR3, a human sits in a mechanical cockpit controlling the robot while seeing the robot's perspective using virtual reality. As the human operator moves his/her limbs, the robot imitates both the direction and force with its own body. In 2019, Toyota unveiled an [updated version](#) of the robot capable of executing more complex tasks including a refined natural walking motion. Then in 2024, Toyota revealed a [modified T-HR3 called "Punyo."](#) Punyo is a soft, bubble-like robot that can complete various tasks using its whole body by effectively squeezing and hugging.



Exhibit 152: Toyota – Company Overview

 <b>Toyota</b>	
Humanoid Robots	Company Profile
	<p><b><u>Founded</u></b> 1937</p> <p><b><u>Headquarters</u></b> Aichi, Japan</p> <p><b><u>Robot Purpose</u></b> General Use Industrial/Logistics Service/Leisure</p> <p><b><u>Description:</u></b> Created T-HR3, a robot that can mimic movement of a human operator. Punyo is a variation of T-HR3 that uses its soft bubble-like body to grip, lift, and interact with its surroundings.</p>
<b>T-HR3 / Punyo</b>	<p><b><u>Stock Ticker</u></b> 7203-JP</p> <p><b><u>Market Cap</u></b> \$278.0 bn</p>

Source: Toyota, FactSet, Morgan Stanley Research

**Tesla (Optimus):** Tesla debuted their Optimus humanoid robot at their [2022 AI Day](#) with multiple subsequent demos showcasing the robot's increasing capabilities. For example, in Sept. 2022, Tesla released a video of [Optimus doing yoga and sorting blocks by color](#). Later, in Dec. 2023, Tesla released a new video showing [Optimus walking a gigafactory floor, poaching an egg, and dancing to EDM](#). CEO Elon Musk has emphasized in the past that Optimus "has the potential to be more significant than Tesla's vehicle business over time." (For more details, see the '[Tesla's Optimus: The Case for Tesla as an AI Enabler](#)' and '[Optimus Prime\(r\)](#)' sections.)



**Exhibit 153:** Tesla – Company Overview

 <b>Tesla</b>	
Humanoid Robots	Company Profile
 <p><b>Optimus</b></p>	<p><b><u>Founded</u></b> 2003</p> <p><b><u>Headquarters</u></b> Austin, Texas</p> <p><b><u>Robot Purpose</u></b> Industrial/Logistics General Use</p> <p><b><u>Description:</u></b> Developing Optimus for use in TSLA factories and external sale. Utilizes TSLA's existing Full Self Driving (FSD) technology.</p> <p><b><u>Stock Ticker</u></b> TSLA</p> <p><b><u>Market Cap</u></b> \$597.5 bn</p>

Source: Tesla, FactSet, Morgan Stanley Research

**UBTech (Walker Series):** UBTech is a Chinese humanoid robotics company that IPO'd in December 2023. It produces the [Walker](#) series of humanoid robots, which are primarily intended as household assistants capable of doing various chores. However, in 2023, the company introduced its first humanoid robot for industrial applications, Walker S. As of June 2024, UBTech has announced a partnership with or shown the robot undergoing testing with [DongFeng Motor](#) and [NIO](#). While also suitable for an array of other applications, UBTech anticipates that growth in the EV industry will be a driver of future demand for its humanoid robot solutions.



**Exhibit 154:**UBTECH – Company Overview

UBTECH	
Humanoid Robots	Company Profile
 <p><b>Walker</b></p>	<p><b><u>Founded</u></b> 2012</p> <p><b><u>Headquarters</u></b> Shenzhen, China</p> <p><b><u>Robot Purpose</u></b> General Service/Leisure Industrial/Logistics</p> <p><b><u>Description:</u></b> Produce humanoid robots for both household service and commercial applications</p>
 <p><b>Walker S</b></p>	<p><b><u>Stock Ticker</u></b> 9880-HK</p> <p><b><u>Market Cap</u></b> \$8.5 bn</p> <p><b><u>IPO Date</u></b> Dec-23</p>

Source: UBTECH, FactSet, Morgan Stanley Research

**Unitree (H-1, G-1):** Unitree is a Chinese robotics startup creating robots for both consumer and commercial use cases. The company was founded in 2016 and initially focused on a variety of quadruped, robot dogs. Eventually, in 2023, the company announced its first humanoid robot, the H-1, followed by its later iteration, [the G-1](#), which gained notable attention for its impressive flexibility, balance, and manipulation coupled with a sale price beginning at only ~\$16k. Both the H-1 and G-1 are currently in production and available for delivery.


**Exhibit 155:**Unitree — Company Overview

Unitree	
Humanoid Robots	Company Profile
 <p><b>H-1</b></p>	 <p><b>G-1</b></p>
	<p><b><u>Founded</u></b> 2016</p> <p><b><u>Headquarters</u></b> Hangzhou, China</p> <p><b><u>Robot Purpose</u></b> General Use Industrial/Logistics</p> <p><b><u>Description:</u></b> Creates a variety of arms and robots, 4-legged and humanoid.</p>
	<p><b><u>Total Raised</u></b> \$166.3 Mn</p> <p><b><u>Startup Stage</u></b> Series B</p> <p><b><u>Notable Backers</u></b> Meituan CITIC Securities Winreal Investment Source Code Capital</p>

Source: Unitree, Crunchbase, Morgan Stanley Research

**Xiaomi (CyberOne):** In August 2022, Xiaomi, China's largest smartphone maker, [debuted](#) its first humanoid robot called "CyberOne" at the company's new product launch event in Beijing. The prototype robot expands upon the company's existing line of consumer electronics by acting as a personal companion capable of completing a wide range of tasks/chores. The robot can also detect human emotion by reading vocal tones and comfort its operator if it detects sadness.

**Exhibit 156:**Xiaomi – Company Overview

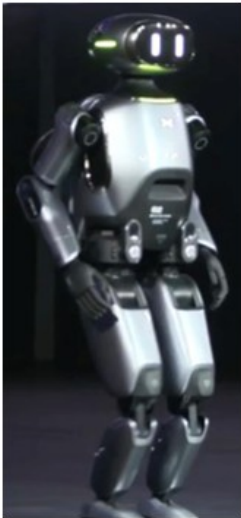
Xiaomi		
Humanoid Robots	Company Profile	
 <p><b>CyberOne</b></p>	<p><b><u>Founded</u></b> 2010</p>	<p><b><u>Stock Ticker</u></b> 1810-HK</p>
	<p><b><u>Headquarters</u></b> Beijing, China</p>	<p><b><u>Market Cap</u></b> \$56.9 bn</p>
	<p><b><u>Robot Purpose</u></b> Service/Leisure</p>	<p><b><u>IPO Date</u></b> Jul-18</p>
	<p><b><u>Description:</u></b> 2nd largest smartphone manufacturer in the world. CyberOne is a prototype humanoid intended as a household assistant.</p>	

Source: Xiaomi, FactSet, Morgan Stanley Research



**XPENG Robotics (PX5):** XPENG Motors is a publicly-traded Chinese automotive company, creating a range of EV sedans and SUVs. In addition to selling EVs, the company has a dedicated robotics subsidiary, [XPENG Robotics](#). XPENG Robotics originally focused on the consumer use-case, developing a robot pony that can act both as a children's toy and a household assistant. Then, in 2023, the company unveiled [the PX5](#), a humanoid robot prototype that the company plans to eventually introduce into its factories and stores.

Exhibit 157: XPENG – Company Overview

XPENG		
Humanoid Robots	Company Profile	
 <p><b>PX5</b></p>	<p><b><u>Founded</u></b> 2014</p>	<p><b><u>Stock Ticker</u></b> 9868-HK</p>
	<p><b><u>Headquarters</u></b> Guangzhou, China</p>	<p><b><u>Market Cap</u></b> \$7.4 bn</p>
	<p><b><u>Robot Purpose</u></b> Industrial/Logistics General Use</p>	<p><b><u>IPO Date</u></b> Aug-20</p>
	<p><b><u>Description:</u></b> One of the largest EV manufacturers in China. PX 5 is a general purpose robot intended to rival TSLA's Optimus.</p>	

Source: XPENG, FactSet, Morgan Stanley Research

# Three Humanoid Primers

## Optimus Prime(r)

**Optimus is Tesla's general-purpose humanoid designed to fully mimic the human body.** The robot was first unveiled at Tesla's 2021 AI Day with the first working prototype unveiled roughly a year later. Unlike many other humanoids, Optimus is designed to fully mimic the human body with a human-like gait, sensor-enabled head, and hands/fingers capable of feeling textures/mass. The robot features 28 fundamental degrees of freedom with 11 additional degrees-of-freedom in each hand (50 DoF total), which are enabled by actuators designed entirely from scratch by Tesla's robotics team. CEO Elon Musk has major plans for the robot, saying it has the potential to be "more valuable than everything else [in Tesla] combined" because of, what he argues, is its ability to entirely nullify meaningful limits to the global economy by enabling an infinite supply of labor. As of 1Q24, Tesla expects Optimus to begin performing useful tasks at its factories by the end of the year with a plan to sell externally by the end of 2025. While the economics of the robot are still unknown, Musk has stated that Optimus could cost much less than a car (~\$20k or less).

**At Tesla's 2024 annual shareholder meeting, CEO Elon Musk argued that Optimus could substantially outgrow the company's core auto business.** Musk believes that, in the long run, the ratio of humanoids to humans will be 2-1 or more, resulting in 10-30 billion (or more) humanoid robots in operation globally. Assuming Tesla could retain a 10% share of production, Musk argued that Tesla could produce 100+ million Optimus units a year, eclipsing the current number of automotives produced globally.

We note that our \$310 price target for Tesla is comprised of auto (hardware), auto-related (software, services) and energy-related businesses. While Tesla's competencies in computer vision, machine learning, AI and robotics may have a multitude of adjacent commercial applications, we have not included such revenue streams (including Optimus) in our model or valuation at this time.

## Optimus Evolution

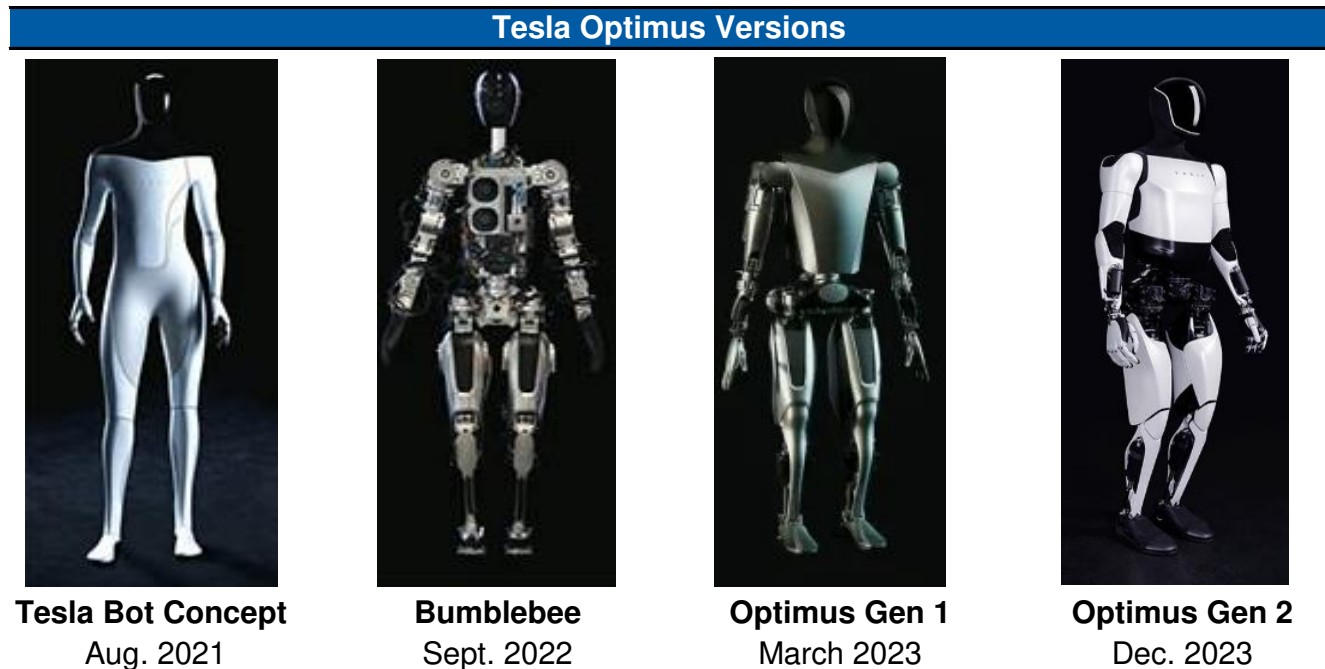
**"Tesla Bot" Concept.** Tesla first revealed the idea for Optimus (then called "Tesla Bot") at its [2021 AI Day](#). While there was no working prototype at the time, Musk unveiled high-level technical and AI capabilities of the planned robot, including leveraging Tesla FSD hardware, Dojo training, and neural net planning.

**Bumblebee/Bumble-C.** At its [AI day in September 2022](#), Tesla conducted the first ever public reveal of its latest humanoid prototype, "Bumble-C," a development off of an early version dubbed "Bumblebee." Bumble-C was able to walk on stage independently with no wires or harnesses and wave to the crowd.

**Optimus Gen 1.** Optimus Gen 1 was unveiled later at Tesla's 2022 AI Day. While the robot was unable to walk independently at the time, it featured a variety of advancements vs. Bumble-C. In particular, Optimus Gen 1 featured an upgraded battery pack, specialized humanoid system-on-chip "brain," and proprietary Tesla-designed actuators customized to the range-of-motion required by the robot. Later at Tesla's March 2023 investor day, Optimus Gen 1 was shown independently walking and performing tasks for the first time.

**Optimus Gen 2.** In December 2023, Tesla released a [YouTube video](#) showcasing its latest developments to Optimus, officially dubbed "Gen 2." The upgraded robot featured a 30% walk-speed boost; 10 kg weight reduction; faster, 11-DoF hands; improved balance and full-body control; tactile-sensing on fingers capable of delicate/soft-object manipulation; foot force/torque sending; and a sleek new design.

Exhibit 158: Optimus Developments Overtime



Source: Tesla, Morgan Stanley Research

### Optimus Technology

**High-Capacity Battery Pack:** In the center of Optimus' torso lies the battery pack. The 2.3 kWh, 52V battery is expected to be fully Tesla-made and capable of "a full day of work." However, we note that specific details on operational time have not been disclosed. Within the pack, all electronics are integrated into a single PCB (printed circuit board) including sensors, diffusers, charge management, and power distribution. The overall design leverages technology from both Tesla's auto and energy businesses, allowing it to be produced using the company's existing supply chain and infrastructure.

**FSD-Enabled Bot Brain:** Also within Optimus' torso is the central computer, or "brain." The design leverages full self driving (FSD) hardware and software modified for the humanoid form-factor, allowing it to be capable of making split second decisions based on vision/sensory inputs. Additionally, the computer features wireless connectivity, audio, safety, and security features.

**Tesla-Designed Actuators:** Actuators are devices that enable motion in a system (both rotational or linear). In a humanoid, these effectively act as joints and muscles. For Optimus, Tesla created their own [in-house actuators](#) from scratch. These actuators are specifically designed to minimize energy, mass, and cost using the company's learnings from car design. From Tesla's perspective, having in-house actuators was crucial because it allows Optimus to have actuators specifically designed to enable the forces and range-of-mo-

tion required for the robot. In total, Optimus features 28 structural actuators, each belonging to 1 of 6 unique designs (3 linear; 3 rotary). Tesla specifically narrowed Optimus' actuators to only a handful of designs to maximize simplicity and cost, enabling greater scalability.

**Biologically-Inspired Hands:** Optimus' hands are specifically designed to mimic human hands. The design utilizes a total of 6 actuators to enable a total of 11 degrees-of-freedom. Additionally, the hands feature a proprietary non-backdrivable, clutching finger drive that allows Optimus to grasp and hold objects without having to constantly run its hand motors. Notably, with Gen 2, Optimus' hands were equipped with tactile sensing on all fingers to allow the robot to safely grip delicate objects. Using all of this technology, Optimus can carry up to 20lbs with ability to precision grip tools and small parts. For Tesla's next generation of Optimus, the company plans to double the degrees-of-freedom to 22.

**Anthropomorphic Navigation/Manipulation:** Optimus fully leverages the neural networks developed for FSD to allow the robot to navigate its surroundings. Once a destination is determined, Optimus uses its embedded cameras and sensors to evaluate reasonable paths/trajectories and coordinate the needed limb movements to get there. When Optimus reaches its destination and is ready to perform a task, the robot will evaluate its positioning and required movements before leveraging a *répétiteur* of pre-programmed natural motion references (for example, bending down or grasping something with both hands) capable of accomplishing the task at hand.

**Exhibit 159:** Red = Actuators; Blue = Electrical Systems. Blue in Middle of Torso = Battery Pack



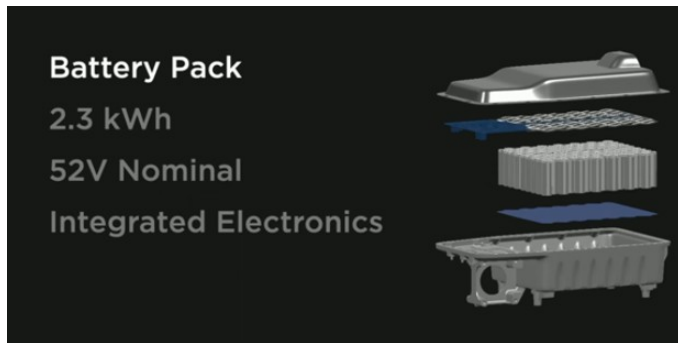
Source: Tesla  
114

**Exhibit 160:** Optimus uses 28 total actuators, each belonging to 1 of 6 different unique designs developed in-house by Tesla (Illustrated by the 6 colors in the below exhibit).



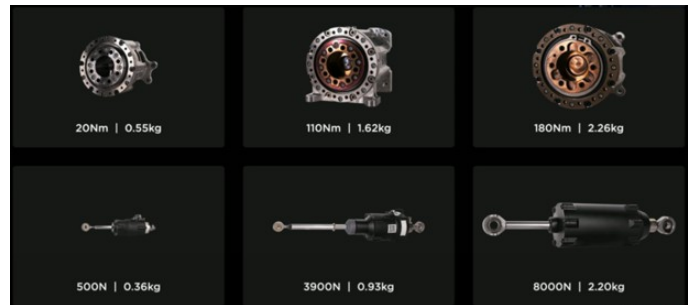
Source: Tesla

**Exhibit 161:** Tesla-Designed Battery for Optimus



Source: Tesla

**Exhibit 162:** 6 Actuator Designs Used in Optimus (3 Rotary, 3 Linear).

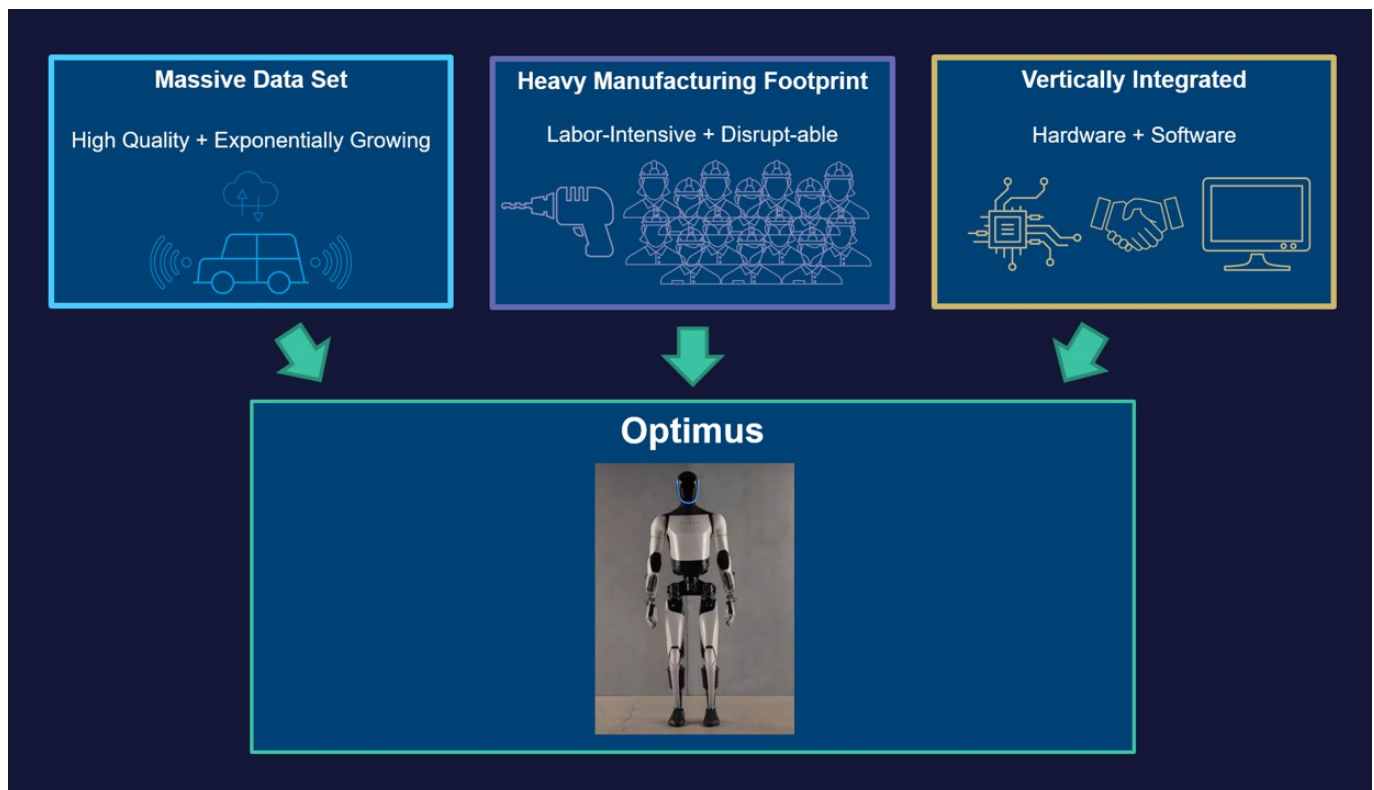


Source: Tesla

In our view, Tesla is uniquely positioned to both enable and benefit from humanoids in our view. Inspired by NVIDIA CEO Jensen Huang's March 2024 [CNBC interview](#), we summarize three key factors supporting the Tesla "AI Enabler" case:

1. **Massive data set that is both *high quality* (edge cases from unique driving situations) and *continuously growing at an accelerating pace* (constantly collecting data from increasing miles driven across growing car parc).**
2. **Massive global manufacturing footprint with labor-intensive processes that are relatively simple to replicate via automation, which creates the opportunity to "observe" and collect data from its own workers to train bots (and continuously iterate upon that pattern).**
3. **Experience in vertically integrating key hardware and software infrastructure.**

**Exhibit 163:** Tesla is Uniquely Positioned to Both Enable and Benefit from Humanoids



Source: Morgan Stanley Research

For more details, see [Appendix III — The Case for Tesla as an AI Enabler](#) .



## Figure AI

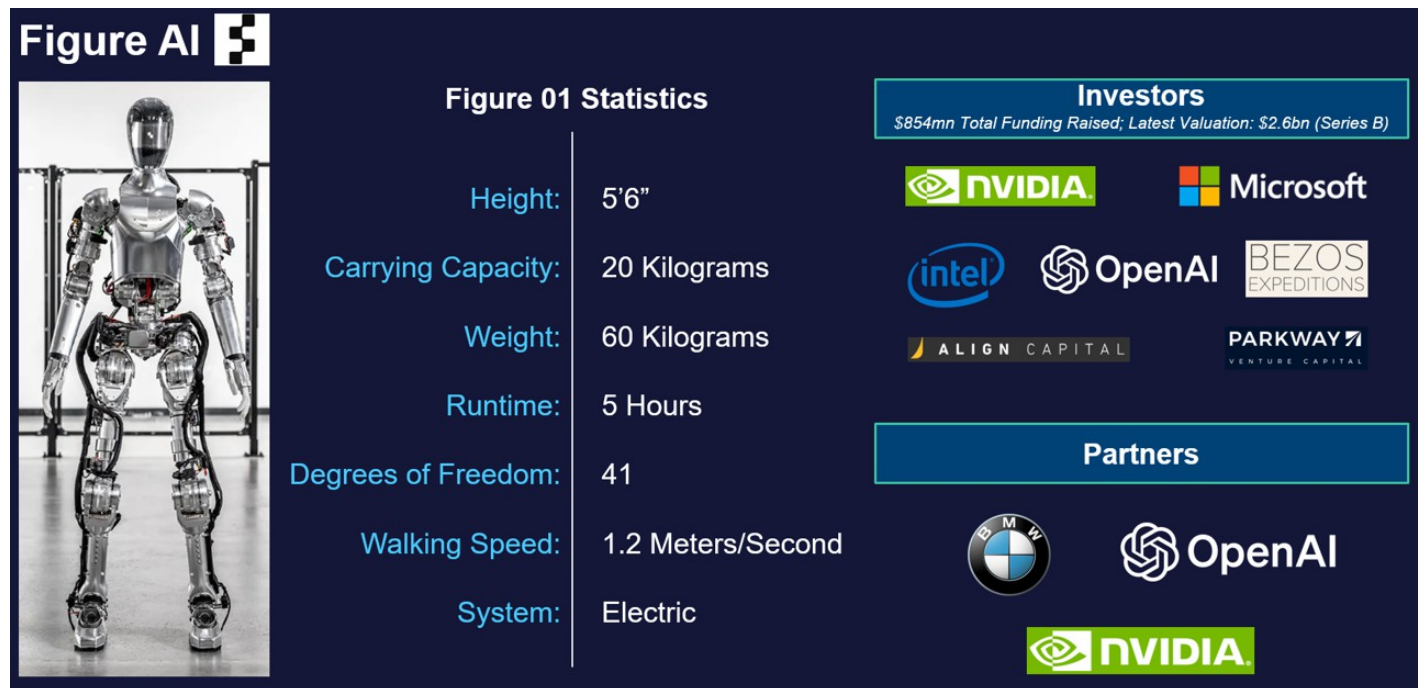
**Figure AI is an upcoming humanoid robotics startup attempting to tackle the global labor shortage.** Figure AI was created in 2022 by Brett Adcock, the founder of VTOL company Archer Aviation (ACHR) and hiring marketplace Vetterly. With roboticists from Tesla and Boston Dynamics, the company is creating Figure 01, an AI-powered, general-purpose humanoid robot designed to tackle human tasks ranging from warehouse work to household chores. In February 2024, the company secured funding from notable investors including Jeff Bezos, Microsoft, NVIDIA, and OpenAI at a valuation of \$2.6 billion. As part of the agreement, OpenAI and Figure agreed to collaborate on humanoid AI models in order to accelerate the development of Figure 01.

### Timeline

- **2022:** Figure AI is founded by Brett Adcock and his team from prior startups Archer Aviation and Vetterly.

- **January 2023:** Figure exits stealth mode.
- **April 2023:** Figure raises \$70mn in a Series A funding round lead by Parkway Venture Capital.
- **October 2023:** [Figure 01 is unveiled](#), demonstrating its ability to independently walk on two legs.
- **January 2024:** Figure announces a partnership with BMW to test Figure 01 at its production facility in Spartanburg, South Carolina.
- **February 2024:** Jeff Bezos, NVIDIA, Microsoft, and OpenAI (among other notable investors) contribute \$675mn in Series B funding at a valuation of \$2.6bn. As part of the deal, Figure and OpenAI announce a partnership to jointly develop "next generation AI models for humanoid robots."
- **March 2024:** Figure 01 demonstrates its ability to use [Speech-to-Speech reasoning](#) to take commands from a human operator using OpenAI large language models.

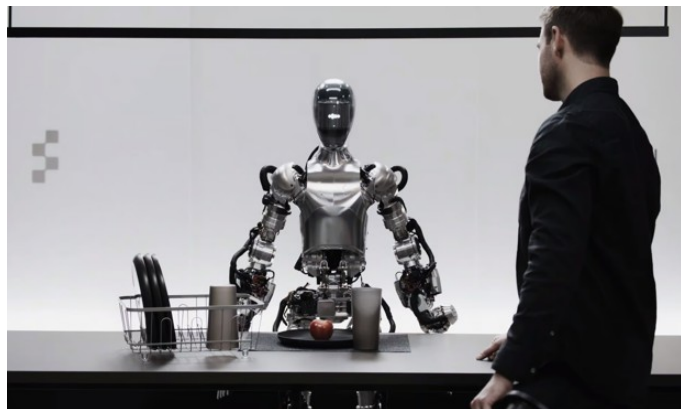
Exhibit 164: Figure AI Profile



Source: Figure, Crunchbase, Morgan Stanley Research

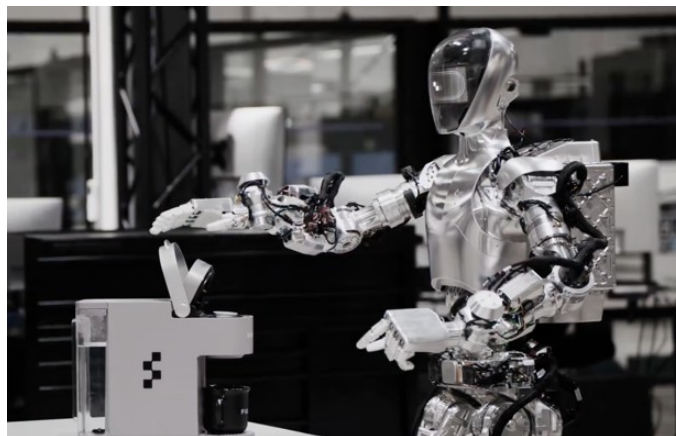


**Exhibit 165:**Figure 01 Demonstrating Speech-to-Speech Reasoning by Taking Commands and Interacting with a Human Operator.



Source: Figure

**Exhibit 166:**Figure 01 Making a Cup of Coffee.



Source: Figure

## NVIDIA Project GrOOT

**Project GROOT is NVIDIA's general-purpose, multimodal foundation model designed specifically for humanoid robots.** Announced at NVIDIA's 2024 GTC Keynote, GROOT is a breakthrough multimodal AI model enabling humanoid robots to understand and interact with the world around it. By utilizing GROOT, robots will be able to utilize a wide array of inputs including vision, human language, or demonstration to accomplish unique and human-like tasks. Per NVIDIA, GROOT is already being utilized by the large majority of humanoid robotics startups globally to accelerate research & development.

“

I may be made of metal, but I don't have sawdust for brains.

”

Rosie the Robot, *The Jetsons*

### GROOT-Enabled Robots Feature 3 Computers:

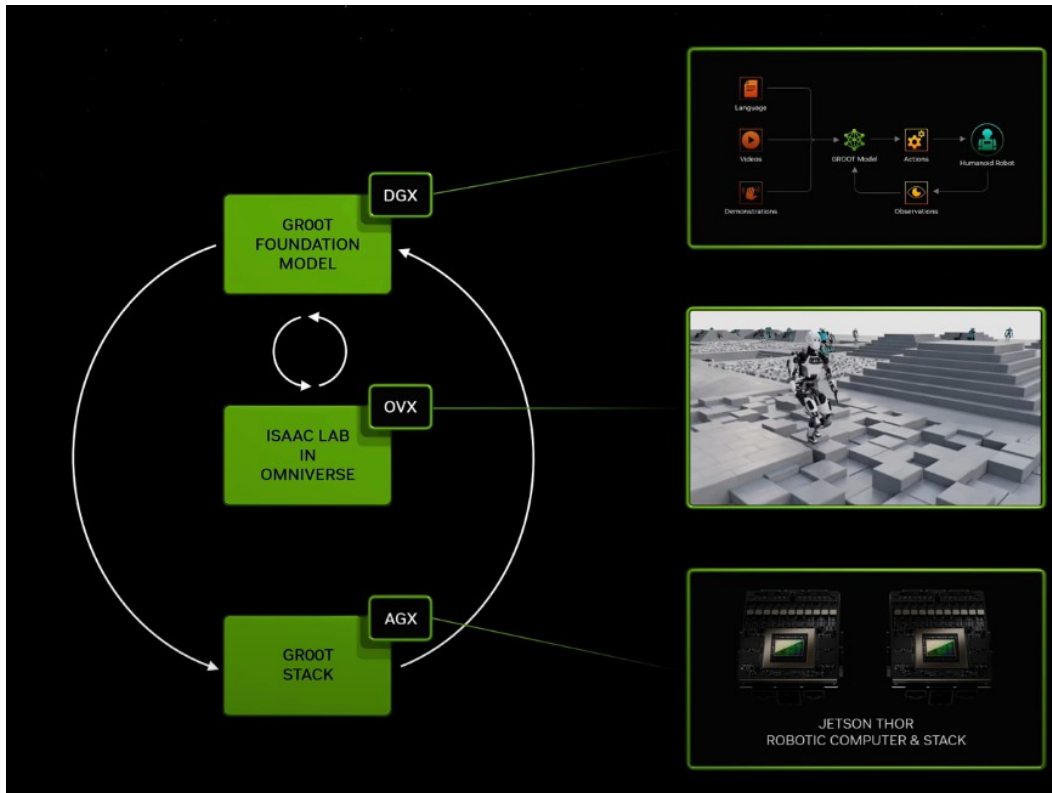
- **Top-Level (AI Model):** [NVIDIA DGX](#)
  - At the highest level is NVIDIA's DGX Platform designed to train the robot to adapt to the physical world around it. This is where the GrOOT Foundation Model lives. As part of the training process, the model receives multi-modal instructions (language, videos, human demonstration) and based on the combination of inputs and context, produces the next physical action for the robot to execute.
- **Middle-Level (Omniverse Digital Twin):** [NVIDIA OVX](#)
  - In between the top-level AI platform and the runtime computer within the robot is a NVIDIA OVX computer running a [digital twin](#) within Omniverse (NVIDIA term for artificial reality), also called "Isaac Sim." Per CEO Jensen Huang, Isaac Sim is essentially a "gym where the robot learns how to be a robot" using reinforcement learning with physical feedback. In layman's terms, the computer creates a simulated version of reality where a robot can attempt various movements, tasks, etc. with reinforced feedback as opposed to training in the real world. For example, imagine seeing a complex obstacle course and having your brain automatically visualize yourself doing it thousands of times before you find the exact way to

beat it. You then do it in the real world in a single attempt. This not only rapidly speeds up the process of learning, but also dramatically increases accuracy and safety.

- **Lower-Level (Edge/Run-time Computer):** [NVIDIA AGX \(Jetson Thor\)](#)
  - Inside the robot is [Jetson Thor](#), the runtime System-on-Chip (SoC) utilizing NVIDIA's latest Blackwell architecture. The chip is specifically designed to synthesize a wide array of sensory inputs while simultaneously handling the obstacle detection, route-planning, and visual odometry required to navigate a robot in its environment. The chip works closely with the GROOT AI model in the DGX-layer, receiving instructions on how to move the robot while sending sensory feedback in return.

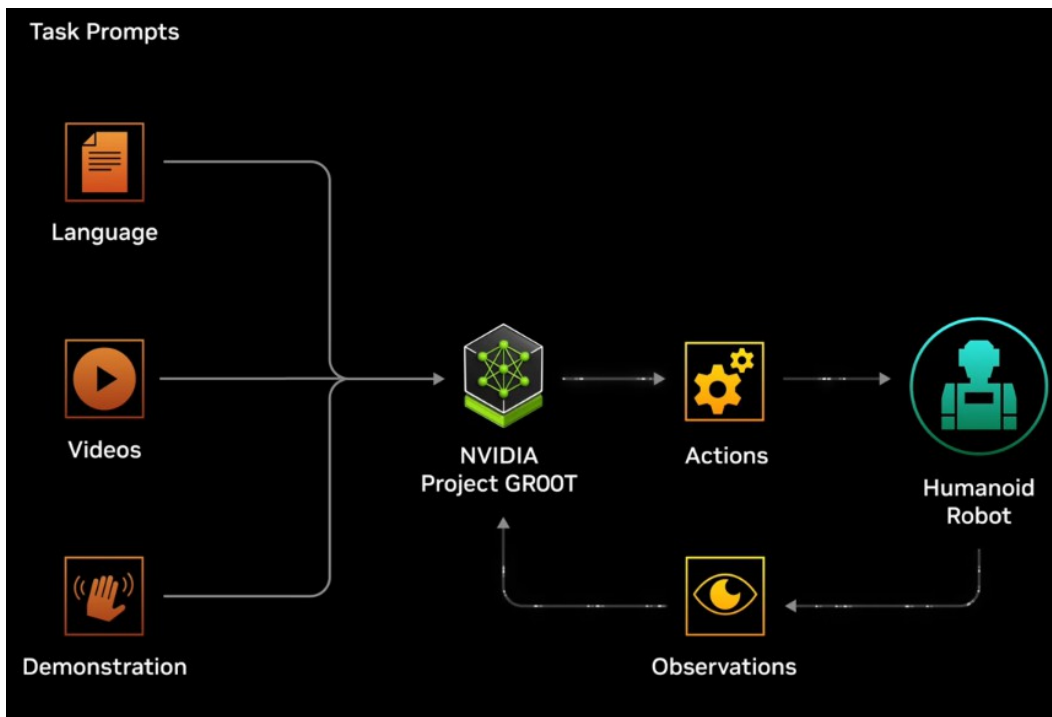
**NVIDIA CEO Jensen Huang has made clear his belief in a robotic future.** For example, at his June keynote address at [Computex](#), Huang argued that "One Day, everything that moves will be autonomous." He later expressed a belief that in the future "all factories will be robotic. The factories will orchestrate robots, and those robots will be building products that are robotic. Robots interacting with robots, building products that are robotic."

**Exhibit 167:** Robots using NVIDIA Project GROOT utilize 3 separate computers: 1) The top-level AI computer (DGX); 2) The Omniverse simulation computer (OVX); and 3) The run-time computer within the robot itself (AGX/Jetson Thor).



Source: NVIDIA

**Exhibit 168:** Using large language models, GROOT is able to receive multimodal instructions (language, videos, human demonstration) and produce the next physical action for the robot to execute.



Source: NVIDIA

**Exhibit 169:** Under Project GR00T, humanoid robots train in a simulated version of reality called "Omniverse." The below image shows digital twins of Aptronik, Agility, and Unitree robots undergoing training.



Source: NVIDIA

# Economic and Labor Considerations

## US Immigration Policy and Politics

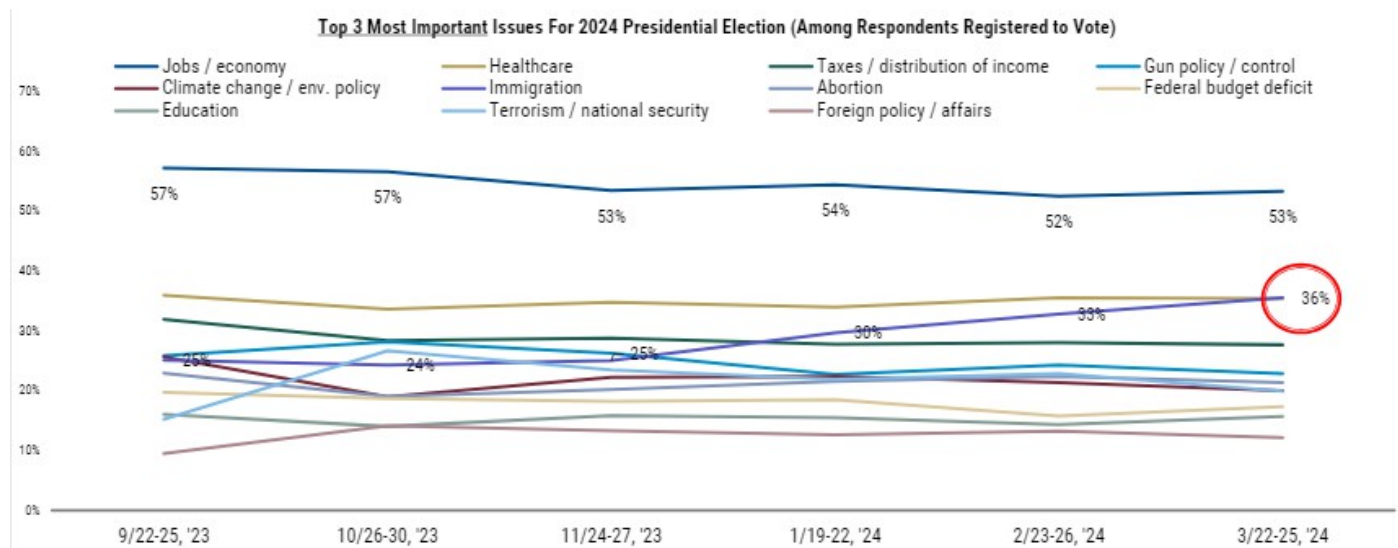
### US Economics and Public Policy

Excerpts from:

- [US Economics Mid-Year Outlook: Fast Growth, More Slack \(19 May 2024\)](#)
- [EM Fixed Income Strategy, Economics & US Public Policy: Immigration Driving Remittances \(12 Apr 2024\)](#)

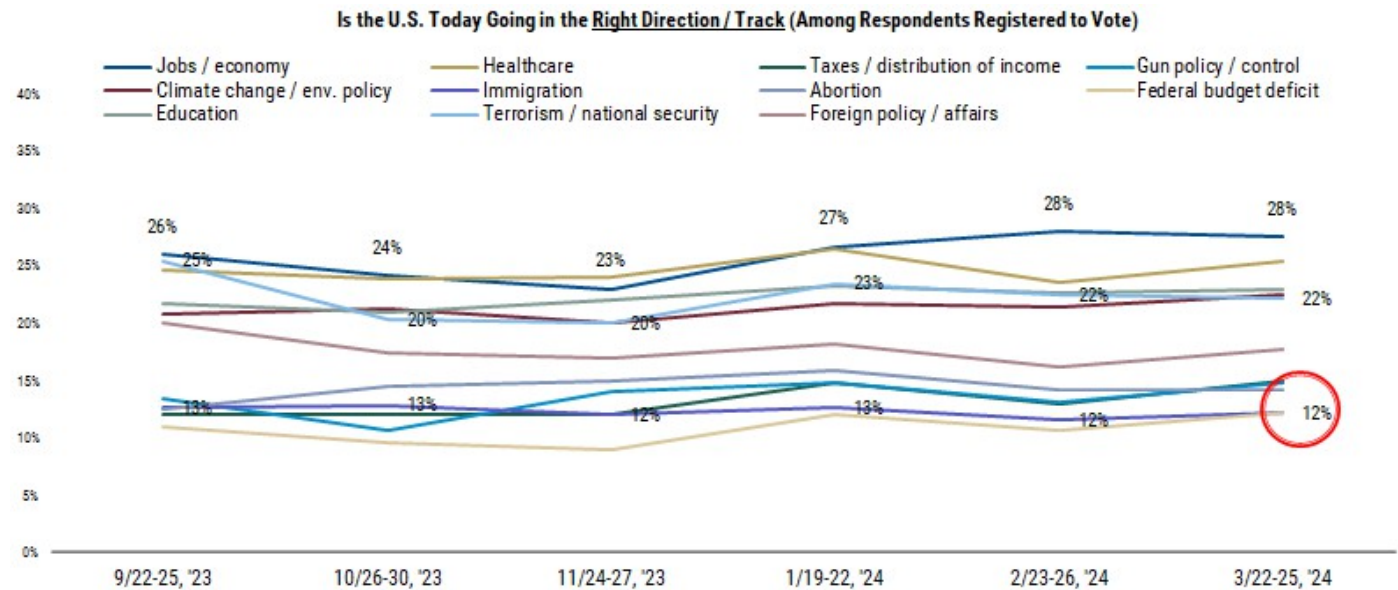
**Immigration has quickly become a key focus of the 2024 presidential election**, as both candidates continue to highlight it as a key issue while on the campaign trail. Public issue polling reflects the salience of this topic as an increasing share of voters are ranking it as a high-priority concern, per the most recent iteration of our AlphaWise Consumer Pulse Survey conducted in March 2024. About 36% of respondents indicate that it is within their top three most important issues for the election, a ~12 pct. pt. increase from last fall and 3pp versus last month. Importantly, only about 12% of voters in that survey indicate that the US is going in the right direction on the issue (the lowest of all categories).

**Exhibit 170:** Registered voters' top three issues for the 2024 election



Source: AlphaWise, Morgan Stanley Research. Note: Research for this report was conducted with Morgan Stanley's AlphaWise, which provides proprietary evidence-based investment research.

Exhibit 171: Registered voters' perception of issues: Right track versus wrong track



Source: AlphaWise, Morgan Stanley Research. Note: Research for this report was conducted with Morgan Stanley's AlphaWise, which provides proprietary evidence-based investment research.

**What the election could mean for immigration:** Although immigration tends to be one of the most difficult policy areas to enact legislative change, we expect that these significant levels of voter dissatisfaction with the current state of play as well as both candidates' emphasis on the importance of the issue could provide an incentive for lawmakers to seek policy reform. Similarly, we believe it's plausible that former President Trump in a potential second term would seek to utilize executive authorities in this area to specifically address the southern border of the United States, which has accounted for a large share of the increase in FY2023.

We note that there is scope for executive authority with respect to immigration policy, although several executive actions that were attempted during former President Trump's first term were challenged or blocked by the courts, including limiting entry points for asylum seekers and revoking temporary protected status for certain classes of migrants. Reports indicate the former president is seeking to employ other avenues as well, which could include actions like Sec. 1182f of US code, which allows the president to "suspend the entry of all aliens or any class of aliens as immigrants or non-immigrants" if entry would be "detrimental to the interests of the United States." President Trump utilized this authority in his first term, and although challenged, it was ultimately upheld by the Supreme Court, which interpreted the Section 1182f authority as granting the president broad power to suspend entry of migrants into the country.

“ One day the AI are going to look back on us the same way we look at fossil skeletons on the plains of Africa. ”

Nathan, Ex Machina



**For that reason, we expect there are potential avenues for executive action that could result in lower rates of immigration in a potential second Trump term**, even if challenged later by courts. Given substantial policy uncertainty, the magnitude or impact of these policies is difficult to assess, but we expect that overall flows would be limited by the implementation of executive actions taken in conjunction with possible concurrent legislative routes.

### Immigration Boosts Potential GDP Growth

One key variable that guides monetary policy is potential GDP, which measures the level of economic activity consistent with a correct supply-demand balance and inflation at target. GDP levels above potential GDP imply that the economy is overheating and inflationary pressures are building.

Like  $r^*$ , potential GDP is a counterfactual and hard to measure in real time. It requires estimating structural models, and the estimates can vary depending on the structure of each model. Besides, potential GDP can change at high frequency too; changes in the labor force, productivity, tax policy, or incentives to invest can all affect potential GDP.

The Fed regularly publishes a longer-run GDP growth estimate, which basically represents trend GDP growth. This estimate can be interpreted as an approximation of potential GDP growth once the effect of near-term factors fades — in other words, a level around which true potential GDP growth fluctuates. The median forecast published in the Summary of Economic Projections has been between 1.8% and 2% since 2015.

As we have pointed out in previous research, **the US economy has been shocked by an important positive supply shock: immigration**. As a result, we updated our population growth estimates meaningfully, moving civilian non-institutionalized population growth from 0.8% to 1.4% in 2023 and 2024, and from 0.7% to 1.1%. And this update has important implications for potential GDP. Larger population due to higher past immigration flows means more production capacity and higher potential GDP levels, which in turn imply a narrower output gap and less inflationary pressures ahead.

Also, higher future immigration flows suggest faster potential GDP growth in the next couple of years. How much higher? It is hard to estimate with precision, but the Fed's estimate of 1.8%-2% can be a useful starting point. Under our assumptions of no meaningful changes in labor productivity growth and labor force participation rates ahead, the elasticity between population and potential growth is just 1. This suggests that the 60bp and 40bp increase in population growth in 2024 and 2025 might move potential GDP to a range of 2.4-2.6% in 2024 and 2.2-2.4% in 2025, much higher than the Fed's current long-run numbers.

While these estimates naturally entail uncertainty, it's clear that **the impact of immigration on potential growth is meaningful over our forecast horizon**.

### Risk to Immigration in 2025

**Immigration has significant implications for population growth, labor supply, and GDP. In our baseline, we assume that net immigration remains at 3.3 million in 2024 before falling to 2.6 million in 2025 (population growth 0.9%Y), on the way back to its pre-COVID pace closer to 1 million.** Breakeven payrolls are 265k in our baseline for 2024 and 210k for 2025.

However, there's considerable uncertainty as immigration policy could change. We lay out our five 2025 immigration scenarios and their implications for population growth and breakeven payrolls (see [Exhibit 172](#)).

The rapid immigration scenario would have flows in 2025 in line with 2023 and 2024 at 3.3 million. This would result in population growth

of 1.4%Y, slightly stronger than 2024 due to growth in the native-born population and breakeven payrolls at 265k/month.

In our three slower immigration scenarios, net immigration ranges from 1.4 million, which would be aligned with the Bipartisan Border Agreement (BBA) target, all the way to zero. In the BBA scenario, net immigration slowing to 1.4 million would result in 0.8%Y population growth and breakeven payrolls at 135k/year. In the normalized scenario immigration is in line with the pre-COVID average of 800k, with 0.6%Y population growth and break-evens similar to pre-Covid at 87k/month. In the deportation scenario net immigration is at zero, caused by low immigration and a rise in emigration (likely due to stricter deportation policies). The population growth is entirely driven by the native-born population, at 0.2%Y, and breakeven payrolls at 45k.

In any post-election outcome, we see stricter immigration policy as highly likely but the extent of changes to immigration policies and enforcement is open to question. The five scenarios outlined below include details on policy changes that could be expected in a second Biden or Trump administration.

**A constriction in labor supply acts as a negative supply shock and would be inflationary. In this scenario, we think the Fed would likely need to keep rates higher for longer, but its reaction would be delayed as negative labor supply slowly begins to feed through into higher inflation.**

Exhibit 172: 2025 Immigration Scenarios

2025 Immigration Scenarios					
Scenario	Deportation	Normalized	Bipartisan Border Agreement (BBA)	Baseline	Rapid Immigration
Population Growth	0.2%	0.6%	0.8%	0.9%	1.4%
Net Immigration (thous)	0	800	1400	2600	3300
Nonfarm Payrolls Breakeven	45k	87k	135k	210k	265k
Description	No net immigration. Population growth reflects native born only.	Pre-Covid immigration flows of 800k/year. Breakeven NFP is near pre-Covid rate of ~87k.	Bipartisan Border Agreement passed and enforced. Immigration flows slow from 3.3mil to 1.4mil. Breakeven estimated ~135k.	Halfway between current immigration flows and Bipartisan Border Agreement. Immigration slows from 3.3mil to 2.6mil, in-line with CBO. Breakeven estimated 210k.	Current immigration flows of 3.3 million persist. Breakeven estimated to be similar to 2024 at 265k.
Policy	Trump wins the election and changes immigration policy mainly through executive action: stricter border policy enforced, as well as deporting some migrants who are already in the US and awaiting trials or working.	Trump wins election and changes immigration policy: Stricter border enforcement via leverage of executive authorities, excluding actions that courts have previously disallowed + some implementation of new authorities.	Trump or Biden wins election and change immigration policy: Limited executive authorities/implementation but Bipartisan Border Agreement curbs crossings	Trump or Biden wins election, but no policy change: No new policy change but flows moderate due to either perceived worse conditions for crossing/general deterrence (Trump) or natural moderation/mean reversion (Biden).	Trump or Biden wins election, but no policy change.

Source: CBO, BLS, Morgan Stanley Research forecasts

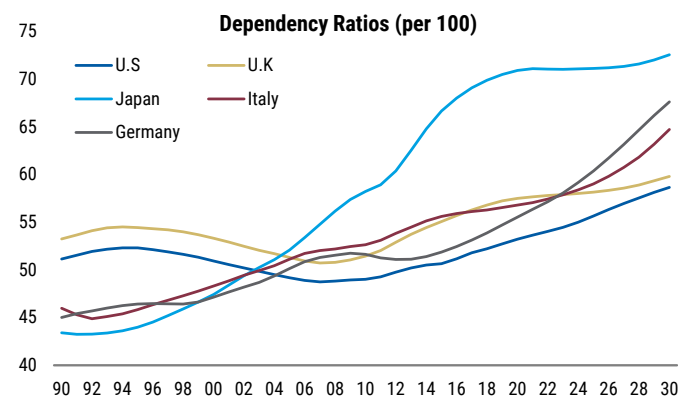
## Global Labor Bottlenecks Meet Robots

### Global Economics

The state of the labor markets in economies around the world will be a key factor in determining the adoption of humanoids and associated capex. In the near-term horizon (over the next couple of years), labor market tightness, in which the demand for labor exceeds its supply, would be a natural candidate in pushing firms to adopt humanoids. However, factors driving tightness in the labor market are different across the economies, which could lead to differential adoptions rates of these technologies.

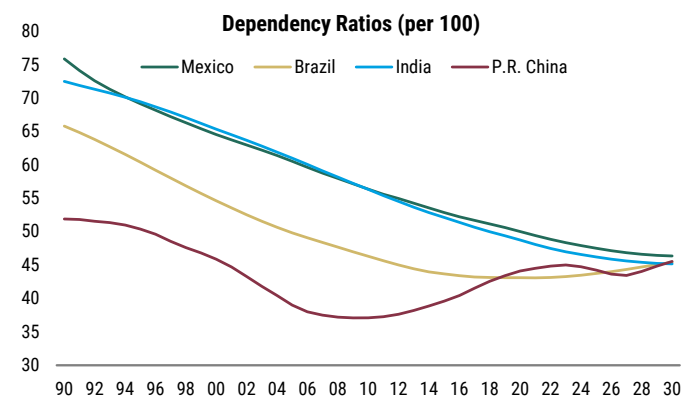
Over a longer time horizon, significant demographic headwinds are expected to lead to structural labor shortages which would support greater automation of tasks and processes across industries. Ex XX shows the dependency ratios across the major economic areas, and these are expected to rise to an average of 65 per 100 by the 2030. Dependency ratios is the ratio of dependent population (<15 years old or 65+) to independent population (15-65 years old).

Exhibit 173: Dependency is rising in the DMs..



Source: UN, Morgan Stanley Research

Exhibit 174: ...unlike in the EM economies

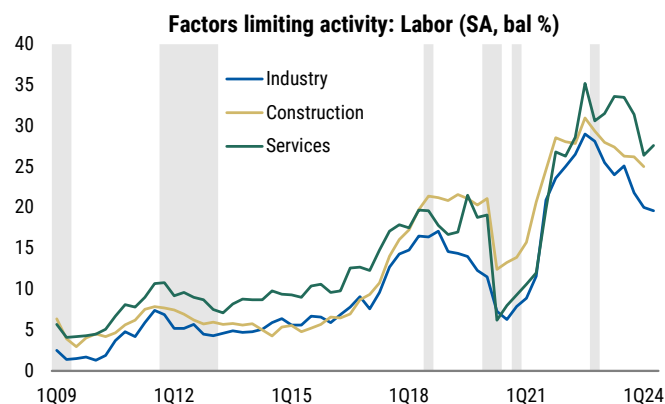


Source: UN, Morgan Stanley Research

**Euro area**

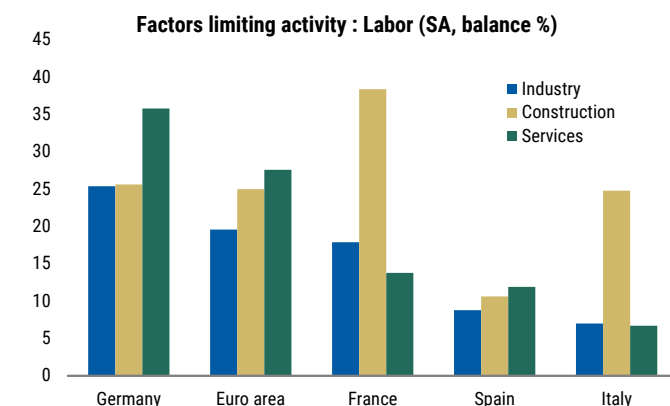
In the euro area, the labor force supply increased in the post-Covid phase and participation rates grew, with the [increases largely driven](#) by women, older workers aged 55 to 74, and immigrants. However, labor markets [continue to remain tight](#) despite weak GDP growth. The phenomenon is broad-based, affecting all sectors. Firms across sectors of the economy report increasing shortage of workers in recent years. While a part of this can be attributed to an increase in demand for output, there has been a structural shortage of labor, given the increasingly ageing population and skill gaps in many professions.

**Exhibit 175:** Business cite labor shortages across sectors



Source: European Commission, Morgan Stanley Research

**Exhibit 176:** The shortage of labor is of greater concern in the core economies

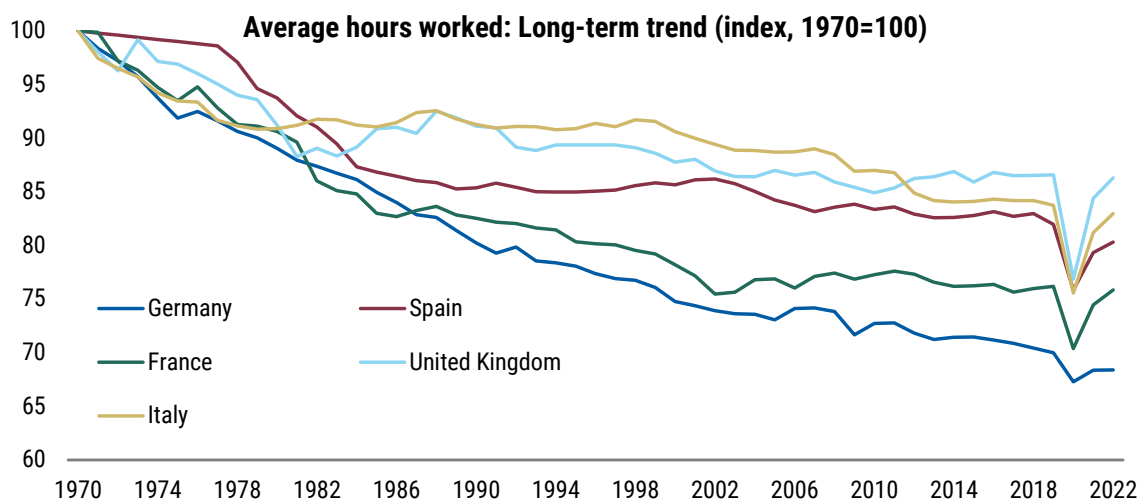


Source: European Commission, Morgan Stanley Research

Our economists also [attribute part of the tightness to a decline in the efficiency in the workforce](#). This declining efficiency has been driven by a decline in the numbers of hours worked, and a fall in measured productivity due to labor hoarding by firms. Both these factors would have an effect on the adoption of humanoids in the production process.

The decline in hours worked is following a secular trend across the euro area economies. [Recent work at the IMF](#) suggests that between 2003 and 2019, among the different worker groups in the EU27 economies, the men, particularly those with young children, and young workers have seen a sharper decline in hours worked than other groups. This decline is a structural phenomenon, reflecting changes in worker preferences and [income effects](#) being larger than substitution effects.

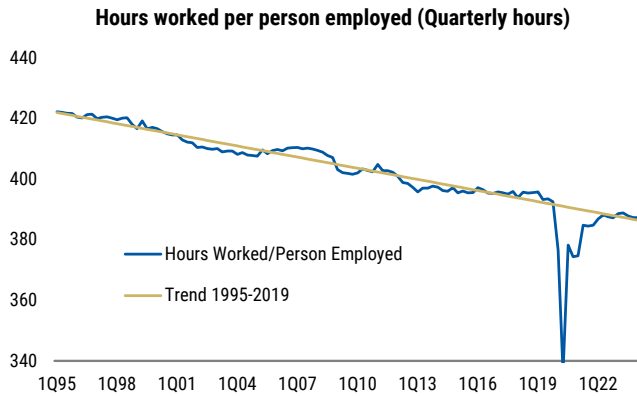
**Exhibit 177:** Average Hours Worked: The Long-term Trend (Index, 1970=100)



Source: OECD, Morgan Stanley Research

Our economists note that the decline in hours is broad based across sectors, with some of the largest declines occurring in manufacturing and industry-ex construction. As noted by our equity analysts below, these sectors could be especially ripe for adoption of humanoids.

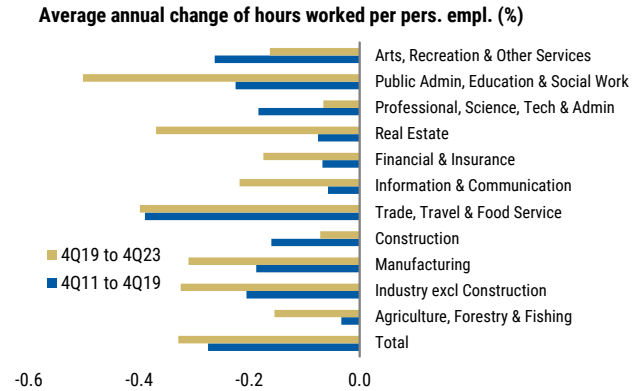
**Exhibit 178:** Secular declining trend in hours worked in the euro area



Source: Eurostat, Morgan Stanley Research

In terms of labor productivity, although some sectors like construction or public services saw a structural shift in the productivity trend to a persistently lower level than before 2019, the decline in measured productivity was largely due to labor hoarding by businesses in both the covid phase and the energy shock period. Our economists forecast an uptick in euro area productivity, from -0.9%Y in 2023 to 0.2%Y in 2024 and 0.8%Y in 2025. They attribute this to a slowdown in hiring (after the labor hoarding phase) and in the growth of the labor force. As business adjust their levels of employment, the adoption of humanoids could drive further productivity increases among the workforce.

**Exhibit 179:** The decline in hours is broad based across sectors



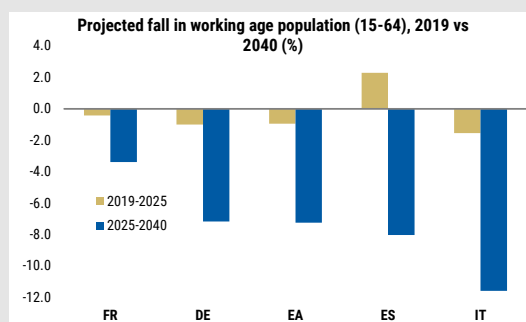
Source: Eurostat, Morgan Stanley Research

Finally, we note that the demographic challenge of a longer-term labor shortage in the euro area is unlikely to be alleviated by net migration. While the euro area experienced large migration flows in 2022 and 2023, this was unusual. Our economists expect that the flows needed to stabilize the euro area working force population are much larger than the historical flow, and it is unlikely that immigration would tackle the issue of adverse demographics over the medium term. Therefore, humanoids in the workforce would help alleviate the demographics induced shortages.

### Germany: Structurally Challenged

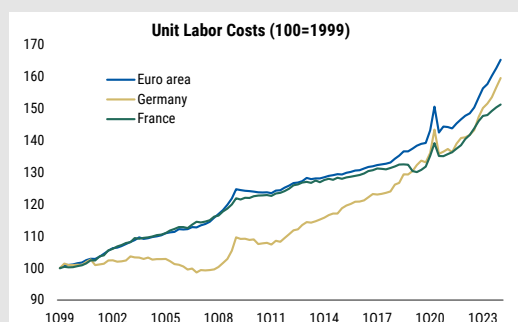
The constraints on demographics are especially highlighted in Germany, where labor shortages have been felt more acutely than in other euro area economies. The labor force is expected to decline in the medium term, despite the large Ukrainian immigration: demographic projections (by Eurostat) estimate a decline of the working age population by more than 7% between 2025 and 2040. Our economists note that this is expected to **further erode the cost competitiveness of labor**, and relative labor costs will be an disadvantage, compared to regions with stable labor structures. This provides a substantial opportunity for increasing the use of humanoids in the production process.

Exhibit 180: Germany is expected to see a large decline in the working age population



Source: Eurostat, Morgan Stanley Research

Exhibit 181: While it had a competitive labor costs in the past decade, those are set to erode with labor shifts



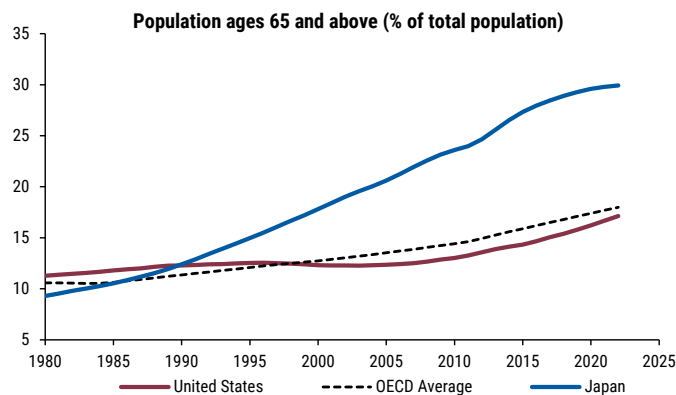
Source: Eurostat, Morgan Stanley Research

## Japan

In Japan, the labor market tightness is due to **structural factors**, and is expected to continue over the medium term. Our Japan economists see a revitalized Japan with stronger nominal growth with positive inflation. Nearshoring and friend-shoring supported by the government’s new industrial policies drive these gains, along with a more capital efficient corporate sector. Private capex is rising in Japan, and is expected to pass its 1991 level, and there has been a marked increase in software investment. This component of the capex cycle would further support the adoption of humanoid adoption across industries.

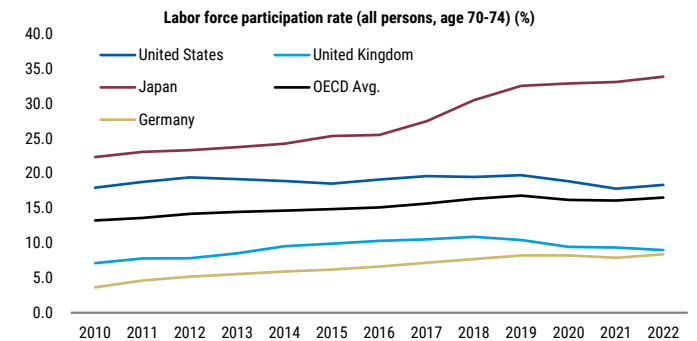
Japan’s demographics mean structural labor shortages are among the most challenging of all the advanced economies in our coverage. Our economists note that businesses report extreme difficulties in finding workers due to demographic factors: the proportion of the population above the ages of 65 is more than 30% of the total population, and there is limited scope for the labor force participation rate to increase for both women and older age groups.

**Exhibit 182:** The population is ageing...



Source: OECD, Morgan Stanley Research

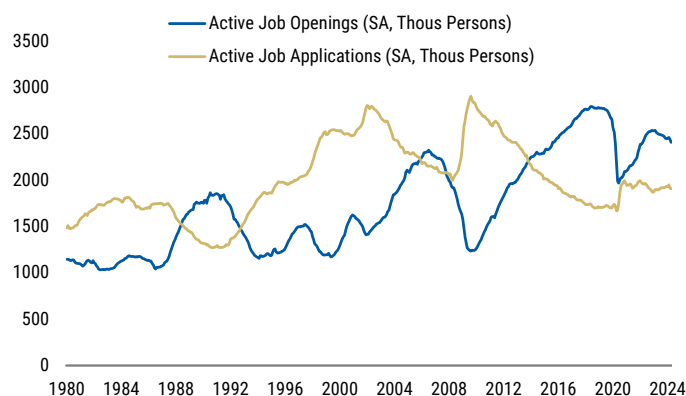
**Exhibit 183:** ...are further increases in LFPR are limited.



Source: OECD, Morgan Stanley Research

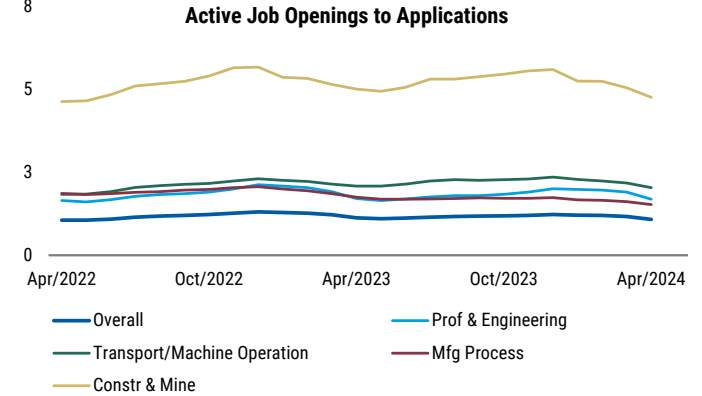
Job openings far exceed job applications, although they are off recent highs. The disparity between applications and openings is particularly stark in the construction and mining worker, and manufacturing process worker, and the professional and engineer worker professions.

**Exhibit 184:** Job openings are higher than applications...



Source: MHLW, Morgan Stanley Research

**Exhibit 185:** ...the disparity is striking in certain sectors.

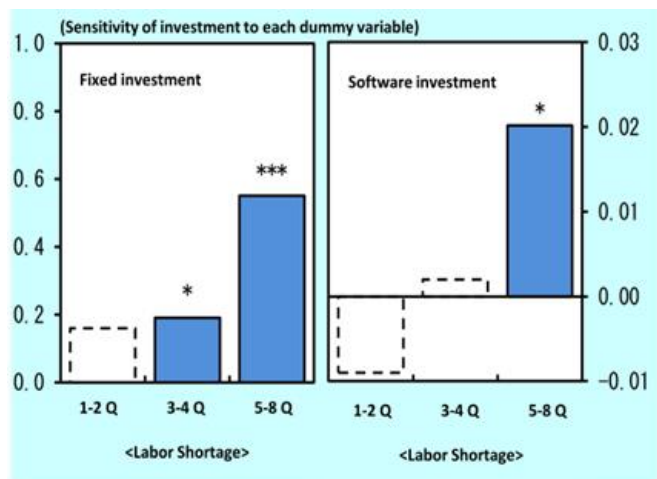


Source: MHLW, Morgan Stanley Research



These labor shortages are prompting firms to undertake larger investments in software. BOJ research highlighted by our economists suggests that labor shortages are driving firm investments in software, and these effects are non-linear over time, i.e., when the shortages persist longer than a certain period, there are larger investments in discontinuous manner.

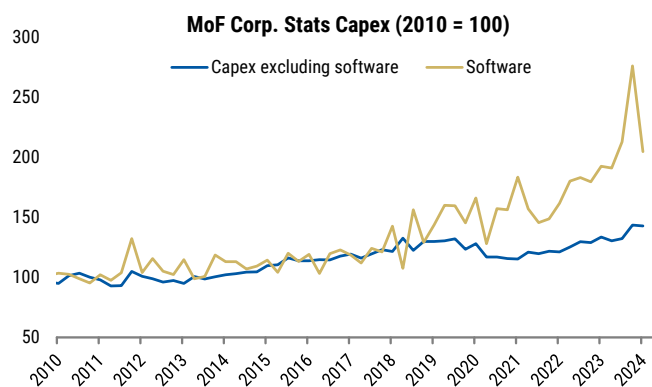
**Exhibit 186:** Non-linear impact of labor shortage on capex



Note: Variables are Tankan Survey basis. Dependent variables: a ratio of fixed investment (ex land) to sales, a ratio of software investment to sales. Independent variables: dummy variables by the number of times that the employment condition was "insufficient" in the current year and the previous year, business condition, sales, and production capacity financial position.

Source: BoJ, Morgan Stanley Research

**Exhibit 187:** Labor-saving investments are evident in data



Source: Ministry of Finance, Morgan Stanley Research

We recently highlighted that Japan's [increased investment in generative AI](#) and semiconductor manufacturing localization represents a marked shift in industrial strategy. Japan aims to triple its sales of domestically produced semiconductors, surpassing US\$108 billion by 2030. Our analysts note that this will be driven by new technologies in AI, next-generation automobiles, and robotics. The public and private spheres in Japan are establishing a comprehensive strategy for AI research and development, which includes funding for

AI-related projects and initiatives. This aim is to boost AI capabilities and innovation in the country.

The diffusion of AI and humanoids into the production processes are also expected in sectors other than semiconductors. Specifically, our analysts see [increased uptake of AI-related and robotics technologies](#) in healthcare and manufacturing.

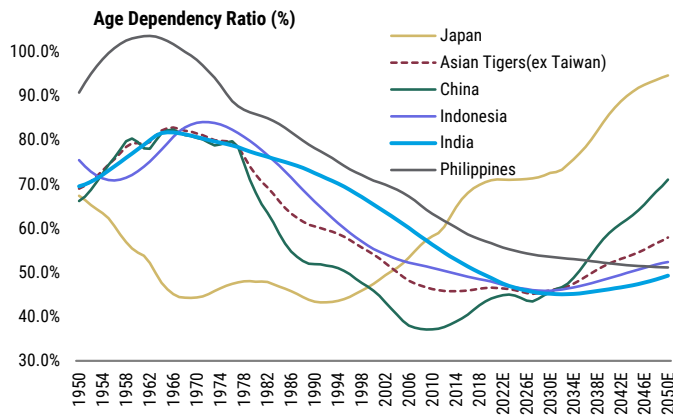
### United Kingdom

In the UK, the [labor market](#) is expected to show some slackening, as the demand for labor appears to be flattening out in the near-term. Although there are data quality issues, structural factors pose significant headwinds in the medium term: participation rates have trended down in the post-covid period, and the data continues to indicate increasing labor market slack. Dependency ratios are also rising. Migration is unlikely to change this in a significant way: even though the UK has seen record large immigration flows (approximately 1% of the UK population between June 2022-23), this pace is unlikely to sustain due to cooling off in labor demand and more structural policy changes. Consequently, there is a long runway for the adoption of humanoids into the production process in different stages over the medium term, and in sectors such as healthcare.

### Emerging Economies

Labor market factors in select emerging economies are in stark contrast to the advanced economies on a number of dimensions. Dependency ratios have been declining, and the economies are expected to add to the working population by 2033. Upgrading the skills of the workforce will be a key issue is driving the adoption of AI and robotics related technologies.

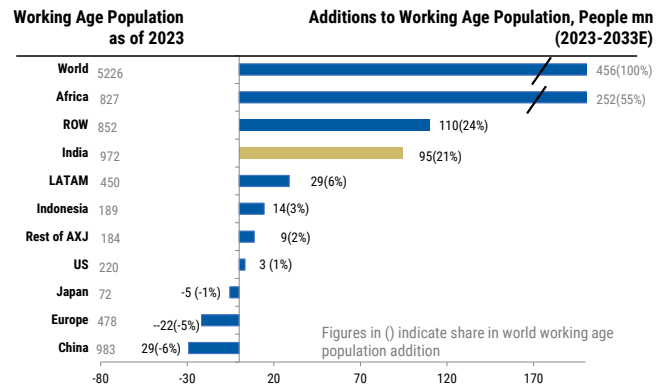
**Exhibit 188:** Dependency ratios are much lower in EMs



Source: UN Population Database, Morgan Stanley Research, E= Estimates from UN Population Database

The adoption of humanoids into the production processes and tasks in these economies will present dual challenges. In the view of our India economists, AI-driven systems and robotics are likely to automate will have effects on the labor force that we have highlighted in previous work: the productivity and reinstatement effects increase labor demand by lowering costs per unit of production and boosting labor productivity, as well as creating new labor intensive tasks. The displacement effect lowers labor demand by allocating processes away from humans to humanoids/AI-enabled machinery. This is likely to increase the demand for AI specialists, data scientists, machine learning engineers, and AI software developers is on the rise.

**Exhibit 189:** India will be a frontrunner in adding working age populations



Source: UN Population Database estimates, Morgan Stanley Research.\* Africa is the sum of 58 countries, ^ Rest of AXJ is 10 AXJ economies ex India, Indonesia and China.

The biggest challenge in the adoption of humanoids in emerging economies are the omnipresent challenges of skill development. For example, in India, skill-based training of the workforce lags behind the advanced economies. Data from the Indian government's periodic labour force survey (PLFS) shows that only 4.4% of India's total workforce (as of F2023) had undergone formal skills training, compared with 52% in the US, 68% in the UK, 75% in Germany, 80% in Japan, and 96% in South Korea. Our India economists note that bridging the skills gap and providing adequate training to the existing workforce will eliminate any demand-supply skill mismatch, and speed up the adoption of humanoids and AI across the production processes.

“

Do not forget what you have learned of our past. From its lessons, the future is forged.

”

Optimus Prime, Transformers

## Obsolete Occupations

Many occupations that were once popular professions no longer exist (or have become near obsolete) due to the advent of new technologies that have automated those jobs, or due to shifts in social/cultural perspectives. As described in a [Stacker article by Hannah Lang \(Sep 2, 2020\)](#), a list of now obsolete occupations includes:

- **Linotype Operator:** Arranged the hot-metal type on presses to publish printed newspapers. Before the Internet and the decline of print.
- **Knocker-Upper:** Knocked on doors to wake residents. Before alarm clocks.
- **Town Crier:** Proclaimed news to townspeople. Before modern education/literacy.
- **Ice Cutter:** Cut ice out of frozen bodies of water (ie. "harvesting ice"). Before fridges/freezers.
- **Bemattist:** Measured distances by counting their steps.
- **Broomsquire:** Artisans who collected birch twigs and then assembled them into brooms.
- **Scibe:** Copied manuscripts and other documents word for word. Before the printing press.
- **Water Carrier:** Collected drinking water and carried it back to villages. Before modern pipe systems.
- **Pinsetter:** Tasked with resetting pins and delivering bowling balls back to the roller in a bowling alley. Before the invention of automatic pinsetters (~early 1950s).
- **Herb Strewer:** Tasked with covering up odors outdoors and indoors using fresh herbs. Before perfumes and modern sewage systems.
- **Lamp Lighters:** People who lit street lamps at night and extinguished them in the morning. Before electricity.
- **Elevator Operator:** Controlled elevators with levers. Before automatic elevators.
- **Drysalter:** Provided chemical products, such as dyes and dry chemicals, in dried, tinned, salted foods, or edible oils, which would be used for dyeing clothes or preserving food.
- **Switchboard Operator:** Manually answered and transferred calls. Before automated telephone switching.
- **Human Computers:** Tasked with manually performing calculations. Before computers.
- **Telegram messenger:** Employed to deliver telegrams, usually on bicycles. Before telephones and other communication innovations.
- **Gandy Dancer:** Railroad workers laid and maintained railroad tracks.

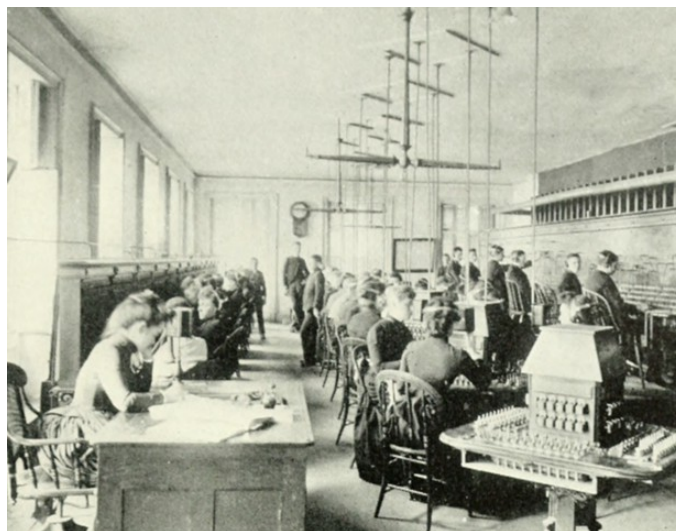
*We note that human history has displayed a constant cycle of both job creation and obsolescence. We do not suggest or believe that humanoids will significantly reduce the size of the global labor force, rather we believe that humanoids have the potential to re-shape the allocation of human labor. For instance, humanoids could increase the output/size of industries reliant on physical labor, resulting in a ripple-effect of job creation for other roles within the industry and in adjacent industries.*

**Exhibit 190:** Ice Cutters Harvesting Ice in Toronto, Canada, 1890s



Source: Wikipedia

**Exhibit 191:** New York telephone exchange, 1880s



Source: Wikipedia

**Exhibit 192:** Human Computers, NACA High Speed Flight Station, 1949



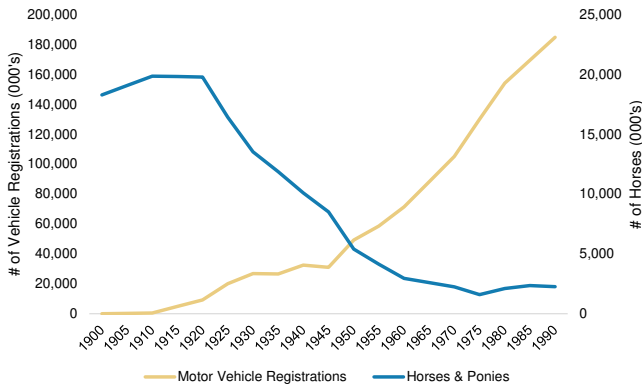
Source: Wikipedia

**Exhibit 193:** Knocker-Upper in Leeuwarden, Netherlands, 1947



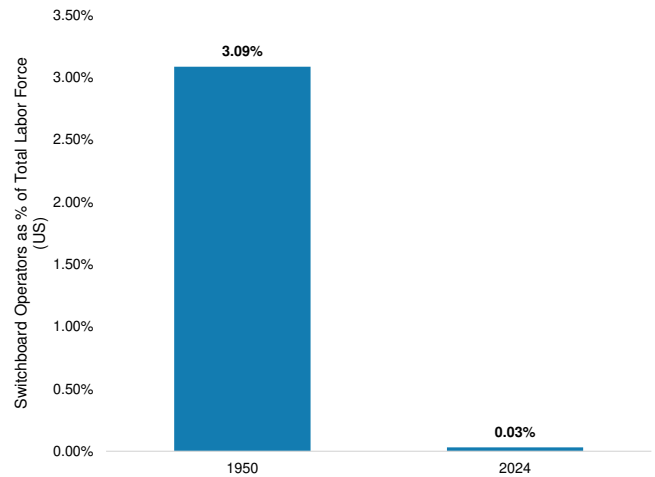
Source: Wikipedia

**Exhibit 194:** Number of Horses vs. Number of Vehicles in the US (1900-1992)



Source: US Department of Agriculture, Federal Highway Administration, Morgan Stanley Research  
 Notes: Chart displays data in increments of 5 years. For years for which motor vehicle registrations and horses & ponies data is unavailable (1905, 1915, 1965, 1980, 1985, 1990), we use a linear methodology between years to approximate the data.

**Exhibit 195:** Switchboard Operators as a % of the Total US Labor Force: 1950 vs. 2024



Source: US Census Bureau, Spark Museum, Morgan Stanley Research



# Appendix I — Humanoid Robots: The World of Physical AI

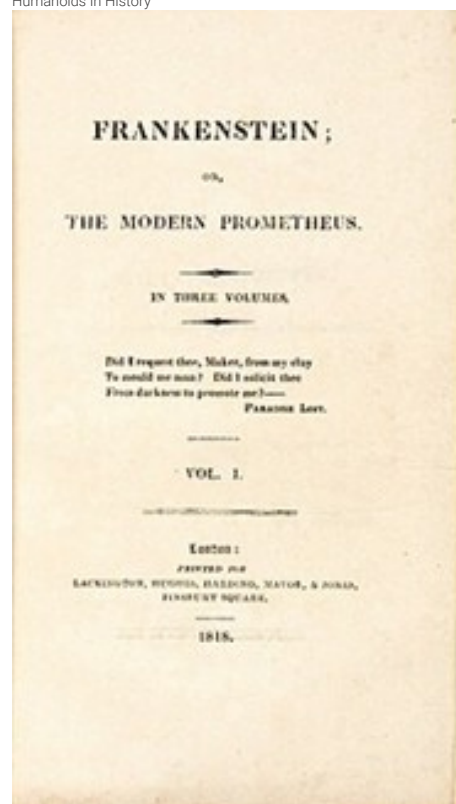
## Humanoids in History

The concept of anthropomorphic machines created by humans for work has been debated and written about for centuries, from Greco-Roman philosophers and scientists to gothic science fiction authors and artists to modern-day Hollywood — the seemingly endless body of work traverses the questions of ethics, what it means to be human, and in modern pop culture oft devolves into 'apocalyptic' scenarios upon the human-made humanoid gaining sentience (or semi-sentience).

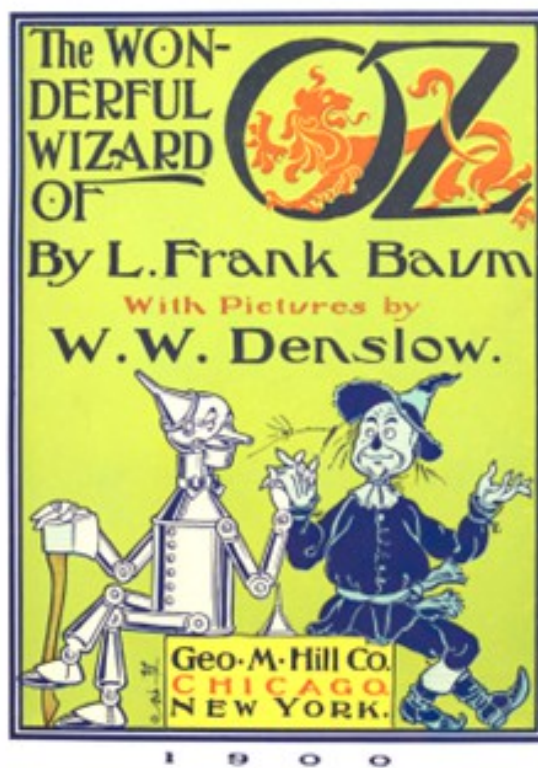
The earliest record of humans exploring the robots conceptually is often attributed to Greek mathematician [Archytas of Tarentum](#), who is said to have created mechanical wooden dove capable of flapping its wings and flying up to 200 meters, propelled by steam as early as the 4th century BC. Aristotle conjectured in *Politics* (~322 BC) the notion that automata could someday bring about human equality by making possible the abolition of forced labor. Leonardo da Vinci produced one of the first recorded designs of a humanoid robot (the [Robotic Knight](#)) circa 1495. There are a number of ancient Buddhist and Daoist texts [contemplating](#) the implications of humanoid auto-

mations (4th-12th century CE), a common thread that can be traced across printed work in various Eurasian religions/ideologies (also appears as a recurring motif in medieval Christian literature). From Mary Shelley's *Frankenstein* (1818) to Isaac Asimov's *I, Robot* (1950), to Philip Dick's *Do Androids Dream of Electric Sheep?* (1968) to HBO's *Westworld* (2016), the thread continues into modern intellectual debate and pop culture. It's difficult to think of another emerging technology associated with such a vast oeuvre transcending history, geography, and ideology with similarly far-reaching socioeconomic implications.

Humanoids in History



Wikipedia



## Exhibit 196: Top Humanoids from Pop Culture

## Famous Humanoids from Pop Culture



**Maria**  
Metropolis (1927)



**Gort**  
The Day the Earth Stood Still (1951)



**Astro Boy**  
Astro Boy (1952-1968)



**Robby**  
Forbidden Planet (1956)



**Rosie the Robot**  
The Jetsons (1962-1987)



**Robot**  
Lost in Space (1965-1968)



**Vision**  
Avengers #57 (1968)



**Androids**  
Westworld (1973)



**C-3PO**  
Star Wars (1977)



**Cylons**  
Battlestar Galactica (1978)



**Marvin**  
The Hitchhiker's Guide to the Galaxy (1979)



**Maximilian**  
The Black Hole (1979)



**Twiki**  
Buck Rogers (1979-1981)



**Replicants**  
Blade Runner (1982)



**T-800**  
Terminator (1984)



**Bishop**  
Aliens (1986)



**Johnny 5**  
Short Circuit (1986)



**Dot Matrix**  
Spaceballs (1987)



**Data**  
Star Trek: The Next Generation (1987)



**RoboCop**  
RoboCop (1987)



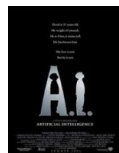
**Optimus Prime**  
The Transformers (1987)



**Tom Servo & Crow**  
Mystery Science Theater 3000 (1988-1996)



**The Iron Giant**  
The Iron Giant (1999)



**David**  
Artificial Intelligence: AI (2001)



**Ava**  
Ex Machina (2014)



**Baymax**  
Big Hero 6 (2014)



**IG-11**  
The Mandalorian (2019)



**Dewey**  
Finch (2021)

Source: Wikipedia, Morgan Stanley Research

We recognize the ethical, philosophical, and existential considerations around the use of humanoid robots in industrial manufacturing and implications across the global goods and services labor

ecosystem, but the breadth of this discussion exceeds the scope of this report.

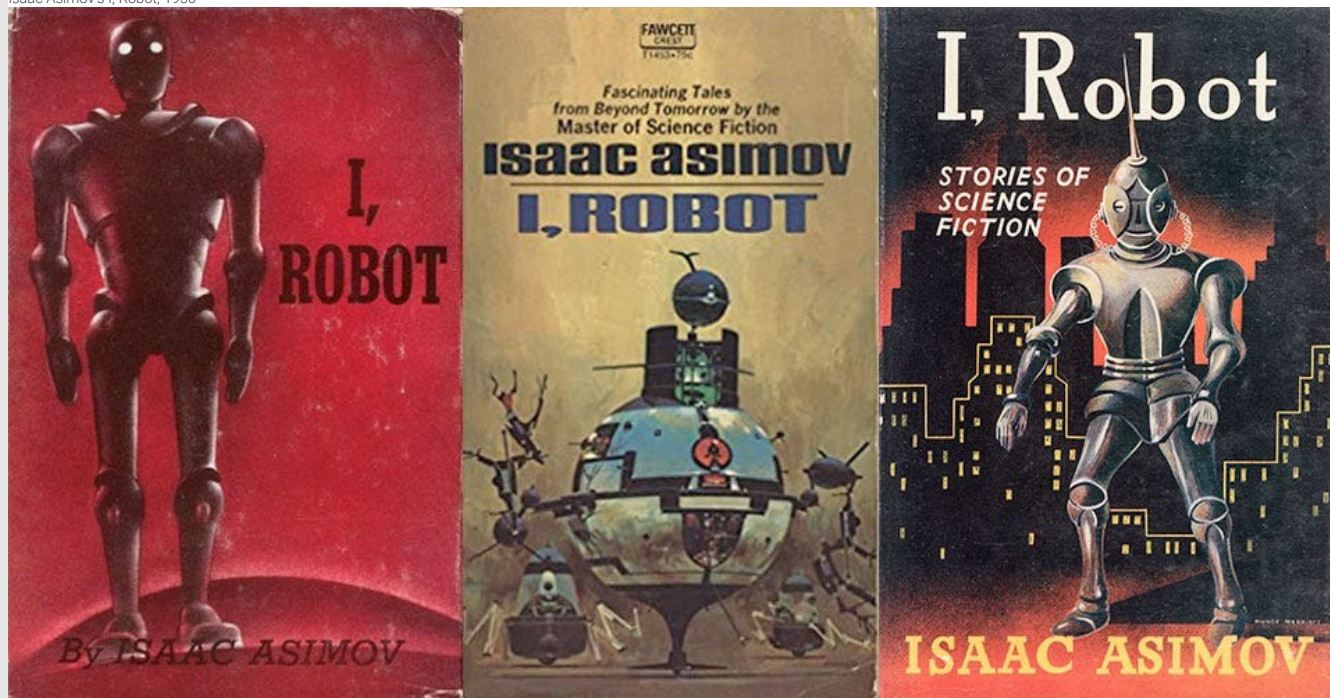
### I, Robot — Isaac Asimov, 1950

Book Description: They mustn't harm a human being, they must obey human orders, and they must protect their own existence...but only so long as that doesn't violate rules one and two. With these Three Laws of Robotics, humanity embarked on perhaps its greatest adventure: the invention of the first positronic man. It was a bold new era of evolution that would open up enormous possibilities—and unforeseen risks. For the scientists who invented the earliest robots weren't content that their creations should remain programmed helpers, companions, and semisentient worker-machines. And soon the robots themselves; aware of their own intelligence, power, and humanity, aren't either.

As humans and robots struggle to survive together — and sometimes against each other — on earth and in space, the future of both hangs in the balance. Human men and women confront robots gone mad, telepathic robots, robot politicians, and vast robotics that may already secretly control the world. And both are asking the same questions: What is human? And is humanity obsolete?



Isaac Asimov's I, Robot, 1950



Wikipedia

We include a summary of notable humanoid milestones below:

- **3rd Century BC (Greece):** In *Argonautica*, Hephaestus, the God of Fire, forges a gigantic bronze humanoid named *Talos* to protect the Greek island of Crete from invaders.
- **1200s (Arabia):** Muslim engineer Ismail al-Jazari detailed designs and instructions for 50 mechanical devices in his book *Kitab fi ma'rifat al-hiyal al-handasiya* (*The Book of Knowledge of Ingenious Mechanical Devices*). Included were mechanical servants able to appear out of an automated door and serve drinks. He has often been referred to as the "Father of Robotics."
- **1495 (Italy):** Leonardo di Vinci designs a mechanical suit of armor in Italy. The knight could sit, stand, and manipulate its limbs through a set of pulleys and cables. In the 1950's, the original schematics for the knight were discovered, and the design has been rebuilt by historians and deemed to be fully functional.
- **1600s (Japan):** During the Edo period, the Japanese developed a range of mechanical dolls called *karakuri ningyo*. The dolls used clock-making technology introduced by European travelers to automatically pour sake, dance, or beat drums for the entertainment of Japanese nobility. Japan has been near the fore-front of humanoid robotics technologies since.
- **1737 (France):** French inventor Janques de Vaucanson became fascinated with human anatomy, leading to the cre-

ation of *The Flute Player*, a life-sized humanoid capable of playing a total of 12 songs on the pipe using mechanized fingers. His inventions were controversial. Some French government officials deemed his inventions "profane," while the King of Prussia was so enamored of Vaucanson's inventions that he attempted to add him to his royal court.

- **1928 (UK):** British WWI veteran William Richards unveils his humanoid robot, *Eric*, as a replacement for the Duke of York, who cancelled an opening address at Exhibition of the Society of Model Engineers, where Richards was secretary. The robot could perform basic movements such as sitting, standing, and raising its arms.
- **1939 (USA):** Westinghouse Electric Corporation creates a humanoid named *Elektro* for the 1939 World's Fair. The robot could move its arms, walk, and smoke a cigarette.
- **1972 (Japan):** Researchers at Waseda University in Tokyo developed the WABOT-1 (WAseda roBOT), commonly agreed to be the world's first ever intelligent humanoid. The robot could walk, pick up objects with its hands, speak in Japanese, and understand distances and directions using a proprietary vision system. According to Waseda University, the robot was estimated to have the mental capability of an 18-month-old human child.
- **1986 (Japan):** Honda released its first line of experimental robots, the E-Series, with a focus on developing robots with a human-like walking nature. The first robot, the EO, could

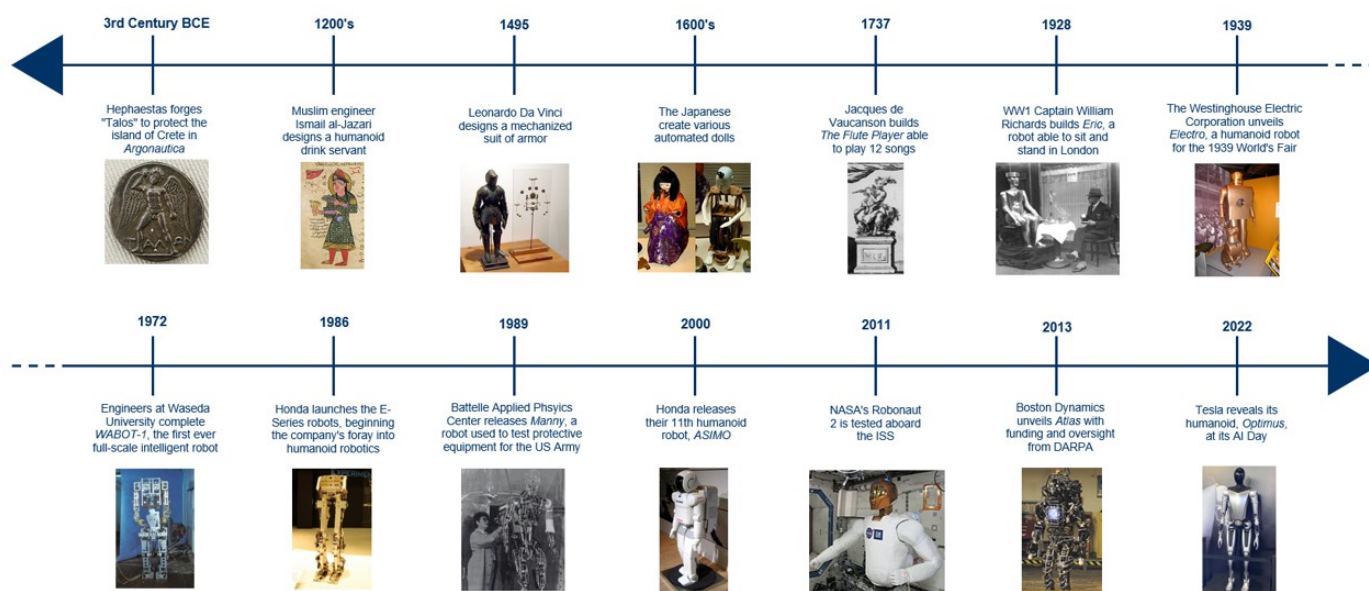
only slowly walk in a straight line. However, by the 7th iteration, the E6, Honda had developed a humanoid that could autonomously balance and climb stairs. The robots would eventually be developed into the P-Series, which introduced a torso and arms.

- **1989 (USA):** During the Cold War, researchers at Battelle Applied Physics Center in Richland, WA released *Manny*, a walking humanoid designed to test leaks in protective clothing for the US Army. The robot was designed to mimic human movement including sweating and breathing through water injectors and an expanding/contracting chest.
- **2000 (Japan):** Honda releases its first iteration of ASIMO (Advanced Step in Innovative Mobility), building upon its prior achievements with the E and P-Series humanoids. In addition to walking and using its hands in a human-like way,

ASIMO was equipped with object, facial, and vocal-recognition technologies allowing it to better interact with humans.

- **2011 (USA):** NASA sends Robonaut 2 to the ISS. Developed alongside General Motors, the robot was NASA's latest attempt to create a robotic crew-member to assist astronauts onboard the space station.
- **2013 (USA):** Boston Dynamics reveals its latest humanoid robot, *Atlas*, with support from the US Defense Advanced Research Projects Agency (DARPA). The robot has been gradually refined and remains active today as one of the most advanced humanoids to date.
- **2022 (USA):** Tesla unveiled *Optimus* at its AI Day. Elon Musk has argued that the humanoid "will be more valuable than everything else [in Tesla] combined."

Exhibit 197: Timeline of Humanoid Robot Developments



Source: Wikipedia, Boston Dynamics, Waseda University, NVIDIA, Morgan Stanley Research

## Historically Transformative Inventions with Global Impact

The list of breakthrough inventions that have changed the world is endless. A brief sample of technological inventions with political, socioeconomic, and business impact:

**Wheel (~3500 BC).** Earliest known development in ancient Sumer, dated 3500 BC, later used in ancient Mesopotamia. Often cited the most important invention in history (because it remains irreplaceable) the advent of the wheel contributed to more efficient transport (people and goods on carts, soldiers on battle chariots, etc.) and the mechanization of industry (agriculture — animal traction, crop irrigation and craft — pottery, windmills).

**Printing Press (1440).** Not only did Johannes Gutenberg's invention enable the mass production of books, it also enabled the spread of ideas, knowledge, and literacy in Europe. The printing press is [commonly](#)

### Exhibit 198: NYC Before the Elevator



Source: Shutterstock, Morgan Stanley Research

**Light Bulb (1880).** Thomas Edison's 1880 invention became an engine for economic growth, enabling productivity and leisure hours to extend beyond daylight hours.

**Airplane (1903).** Piloted by the Wright Brothers in 1903 (in symphony with other early aviation heroes such as Charles Lindbergh), the invention of the airplane launched the foundations of aeronautical engineering, accelerated cross-cultural and economic trade, and built the multi-trillion dollar travel and tourism industry.

[only attributed](#) to the widespread dissemination of Martin Luther's 95 Theses and subsequent Protestant Reformation as well as facilitating the revolution that accelerated the transition from the Middle Ages to the Renaissance. It also gave rise to a new industry of printers, booksellers and writers.

**Elevator (1853).** Elisha Graves Otis's 1853 invention changed the social and architectural landscape of cities. It changed the way society perceived residential housing (top floor was previously undesirable) — the elevator built prestige around the high-rise/penthouse apartment. Beyond societal perceptions, the opportunity enabled by the elevator was truly transformative — city planners could build up rather than out (see NYC before and after the elevator). The world's cities contain more than half of the global population but, [as of 2012](#), cover less than 3% of its land.

### Exhibit 199: NYC After the Elevator



Source: Shutterstock, Morgan Stanley Research

**Penicillin (1928).** Scottish researcher Sir Alexander Fleming's discovery in 1928 changed the process of drug discovery — its large-scale production [transformed](#) the pharmaceutical industry, and its clinical use changed forever the therapy for infectious diseases.

### The list continues...

- **Artificial Intelligence (1950s).**
- **Mobile Phone (1973).**
- **Internet (1983)..**



## Appendix II — AlphaWise Humanoid Transcript Analysis

### Where is Labor & Automation Most Topical?

**With the help of our AlphaWise team, we conducted a keyword-analysis on transcripts of companies in the S&P500 to determine where labor and automation is being mentioned the most.** When conducting the analysis, we screened transcripts for keyword mentions of 416 labor pressure-related terms, explicit mentions of "automation" and "automate," and 17 robotics-related terms. Results for each category are outlined below:

#### Labor Mentions

- **Keywords Include:** Labor Shortage, Wage Inflation, Employee Turnover, Unionization, etc.
- The analysis showed that companies in the Industrial/Materials (36% of mentions), Consumer (19% of mentions), and Healthcare (18% of mentions) sectors have mentioned labor pressure the most over the past 4 quarters.
  - *In Industrial/Materials, notable companies include:* Waste Management (23 mentions), Aptiv (17 mentions), General Motors (13 mentions), Southwest Airlines (10 mentions), and Union Pacific (9 mentions).
  - *In Consumer, notable companies include:* Chipotle Mexican Grill (15 mentions), Darden Restaurants (8 mentions), Kimberly-Clark (7 mentions), Sysco (7 mentions), and MGM Resorts (6 mentions).
  - *In Healthcare, notable companies include:* HCA Healthcare (17 mentions), Quest Diagnostics (8 mentions), STERIS (8 mentions), IDEXX Laboratories (8 mentions), and Labcorp (6 mentions).
- Companies were generally referring to ongoing initiatives to reduce labor costs via headcount reductions, pockets of ongoing labor shortage, and unionization (most notably in autos and healthcare services).
- **Labor mentions spiked during 2021 with the frequency gradually normalizing since. However, in 2024, ~16% of S&P500 transcripts have mentioned labor, still notably higher than the 2010-19 average of 10.5%.**

#### Automation Mentions

- **Keywords:** Automation and Automate.
- The analysis showed that companies in the Industrial/Materials (35% of mentions), TMT (30% of mentions), and

Financials (12% of mentions) sectors have mentioned automation the most over the past 4 quarters.

- *In Industrial/Materials, notable companies include:* Honeywell (61 mentions), Emerson Electric (58 mentions), Sealed Air (32 mentions), Waste Management (30 mentions), and Rockwell Automation (27 mentions).
- *In TMT, notable companies include:* IBM (36 mentions), Zebra Technologies (33 mentions), Synopsys (31 mentions), Cognizant Technology Solutions (24 mentions), and F5 (21 mentions).
- *In Financials, notable companies include:* MarketAxess (69 mentions), Intercontinental Exchange (24 mentions), Citigroup (9 mentions), BNY Mellon (7 mentions), and BlackRock (5 mentions).
- Companies were generally referring to introducing automation on production lines or creating technologies to enable automation. In TMT, many companies were referring to process automation rather than automation of physical labor. In Financials, companies were referring to automation of trading procedures, data analysis, and back-office tasks.
- **Automation mentions have consistently increased since 2015 from ~10% of S&P 500 transcripts to ~25% in 2024.**

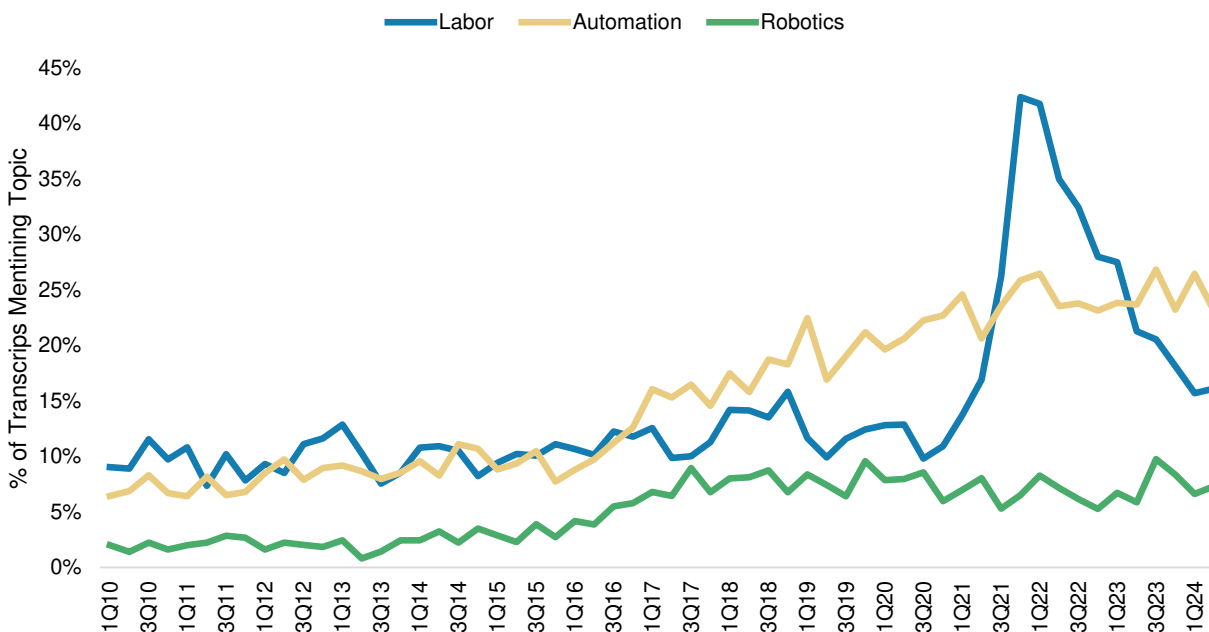
#### Robotics Mentions

- **Keywords include:** Robotics, Bots, Drone, Droid, etc.
- The analysis showed that companies in the Industrial/Materials (42% of mentions), Healthcare (33% of mentions), and TMT (18% of mentions) sectors have mentioned robotics the most over the past 4 quarters.
  - *In Industrial/Materials, notable companies include:* Teradyne (111 mentions), Tesla (76 mentions), Axon Enterprise (51 mentions), Teledyne Technologies (12 mentions), and Rockwell Automation (6 mentions).
  - *In Healthcare, notable companies include:* Intuitive Surgical (62 mentions), Stryker (62 mentions), Medtronic (38 mentions), Johnson & Johnson (23 mentions), and Zimmer Biomet (19 mentions)
  - *In TMT, notable companies include:* F5 (20 mentions), Akami Technologies (19 mentions), NVIDIA (17 mentions), Zebra Technologies (12 mentions), and Live Nation (8 mentions).
- Companies with the most mentions are actively developing robotics technology/solutions. In Industrials/Materials, com-

panies mentioning robotics are generally developing solutions for manufacturing or defense applications. In Healthcare, most mentions referred to robotic-assisted surgery. In TMT, mentions were split between referring to viruses/computer 'bots' and referring to developing systems that support actual robotic solutions.

- **Robotics mentions have also increased along with automation mentions, but to a lesser extent. In 2Q24, ~7.5% of S&P 500 transcripts mentioned robotics vs. ~3% in 2015.**

**Exhibit 200:** % of S&P 500 Transcripts with Labor, Automation, and Robotics Mentions



Note: Refers to quarter that transcript took place. For example, 1Q24 earnings would fall in 2Q24.  
 Source: AlphaWise, Morgan Stanley Research

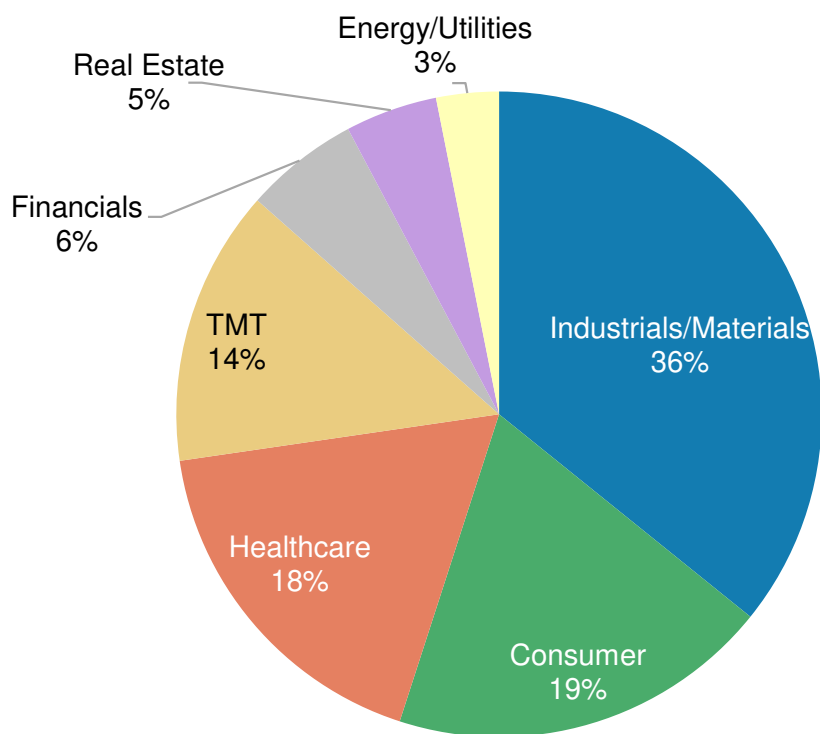
Exhibit 201: Top 25 Companies Mentioning Labor Pressure Over the Past 4 Quarters (3Q23 - 2Q24)

Labor Pressure Mentions in Past 4 Quarters						
Rank	Mentions	Ticker	Mkt Cap (\$mn)	Company Name	Industry	Broader Sector
1	23	WM.N	84,428	Waste Management, Inc.	Environmental Services	Industrials/Materials
2	17	APTV.N	22,769	Aptiv PLC	Auto Parts: OEM	Industrials/Materials
3	17	HCA.N	84,308	HCA Healthcare Inc	Hospital/Nursing Management	Healthcare
4	15	CMG.N	88,800	Chipotle Mexican Grill, Inc.	Restaurants	Consumer
5	13	GM.N	51,754	General Motors Company	Motor Vehicles	Industrials/Materials
6	11	MAA.N	15,928	Mid-America Apartment Communities, Inc.	Real Estate Investment Trusts	Real Estate
7	10	LUV.N	16,326	Southwest Airlines Co.	Airlines	Industrials/Materials
8	9	IBM.N	152,736	International Business Machines Corporation	Packaged Software	TMT
9	9	UNP.N	150,462	Union Pacific Corporation	Railroads	Industrials/Materials
10	9	UPS.N	107,995	United Parcel Service, Inc. Class B	Air Freight/Couriers	Industrials/Materials
11	8	DGX.N	15,348	Quest Diagnostics Incorporated	Services to the Health Industry	Healthcare
12	8	DRI.N	17,536	Darden Restaurants, Inc.	Restaurants	Consumer
13	8	FDS.N	16,618	FactSet Research Systems Inc.	Data Processing Services	TMT
14	8	STE.N	22,331	STERIS plc	Medical Specialties	Healthcare
15	7	CHTR.O	38,108	Charter Communications, Inc. Class A	Cable/Satellite TV	TMT
16	7	IDXX.O	41,361	IDEXX Laboratories, Inc.	Medical Specialties	Healthcare
17	7	JKHY.O	12,318	Jack Henry & Associates, Inc.	Packaged Software	TMT
18	7	KMB.N	46,015	Kimberly-Clark Corporation	Household/Personal Care	Consumer
19	7	SYY.N	37,423	Sysco Corporation	Food Distributors	Consumer
20	7	TDG.N	73,801	TransDigm Group Incorporated	Aerospace & Defense	Industrials/Materials
21	6	FCX.N	73,376	Freeport-McMoRan, Inc.	Other Metals/Minerals	Industrials/Materials
22	6	LH.N	17,377	Laboratory Corporation of America Holdings	Services to the Health Industry	Healthcare
23	6	META.O	1,041,857	Meta Platforms Inc Class A	Internet Software/Services	TMT
24	6	MGM.N	12,814	MGM Resorts International	Casinos/Gaming	Consumer
25	6	UHS.N	10,618	Universal Health Services, Inc. Class B	Hospital/Nursing Management	Healthcare

Note: Includes mentions of words such as "Wage inflation," "Labor shortage," "Unionization," etc. Refers to quarter that transcript took place. For example, 1Q24 earnings would fall in 2Q24.

Source: AlphaWise, Morgan Stanley Research

Exhibit 202: Labor Pressure Mentions Across the S&P 500 Over the Past 4 Quarters by Sector.



Source: AlphaWise, Morgan Stanley Research



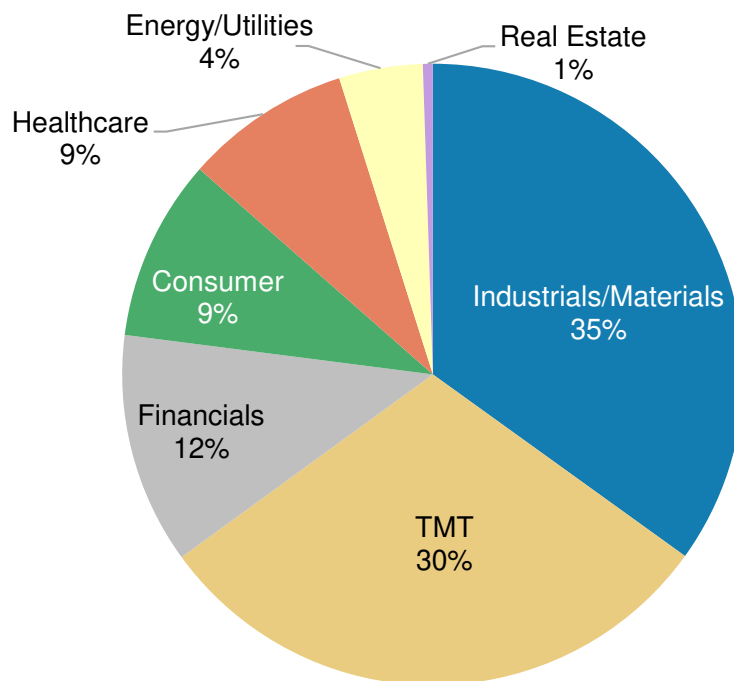
Exhibit 203: Top 25 Companies Mentioning Automation Over the Past 4 Quarters (3Q23 - 2Q24)

Automation Mentions in Past 4 Quarters							
Rank	Mentions	Ticker	Mkt Cap (\$mn)	Company Name	Industry	Broader Sector	
1	69	MKTX.O	7,762	MarketAxess Holdings Inc.	Investment Banks/Brokers	Financials	
2	61	HON.O	130,647	Honeywell International Inc.	Aerospace & Defense	Industrials/Materials	
3	58	EMR.N	66,129	Emerson Electric Co.	Electronic Equipment/Instruments	Industrials/Materials	
4	36	IBM.N	152,736	International Business Machines Corporation	Packaged Software	TMT	
5	33	ZBRA.O	16,274	Zebra Technologies Corporation Class A	Computer Processing Hardware	TMT	
6	32	SEE.N	5,458	Sealed Air Corporation	Containers/Packaging	Industrials/Materials	
7	31	SNPS.O	83,881	Synopsys, Inc.	Packaged Software	TMT	
8	30	WM.N	84,428	Waste Management, Inc.	Environmental Services	Industrials/Materials	
9	27	ROK.N	30,838	Rockwell Automation, Inc.	Electrical Products	Industrials/Materials	
10	24	AME.N	39,327	AMETEK, Inc.	Electrical Products	Industrials/Materials	
11	24	CTSH.O	33,213	Cognizant Technology Solutions Corporation Cl	Information Technology Services	TMT	
12	24	ICE.N	77,405	Intercontinental Exchange, Inc.	Investment Banks/Brokers	Financials	
13	23	BDX.N	67,917	Becton, Dickinson and Company	Medical Specialties	Healthcare	
14	23	WMT.N	487,134	Walmart Inc.	Specialty Stores	Consumer	
15	21	FFIV.O	10,025	F5, Inc.	Packaged Software	TMT	
16	20	NOW.N	148,203	ServiceNow, Inc.	Packaged Software	TMT	
17	20	TER.O	19,141	Teradyne, Inc.	Electronic Production Equipment	Industrials/Materials	
18	18	TDY.N	18,619	Teledyne Technologies Incorporated	Aerospace & Defense	Industrials/Materials	
19	17	CDNS.O	77,634	Cadence Design Systems, Inc.	Packaged Software	TMT	
20	17	DGX.N	15,348	Quest Diagnostics Incorporated	Services to the Health Industry	Healthcare	
21	17	MTD.N	27,599	Mettler-Toledo International Inc.	Medical Specialties	Healthcare	
22	17	PANW.O	95,531	Palo Alto Networks, Inc.	Packaged Software	TMT	
23	16	META.O	1,041,857	Meta Platforms Inc Class A	Internet Software/Services	TMT	
24	14	ADSK.O	47,110	Autodesk, Inc.	Packaged Software	TMT	
25	14	CRM.N	266,993	Salesforce, Inc.	Packaged Software	TMT	

Note: Includes only mentions of "Automation" or "Automate." Refers to quarter that transcript took place. For example, 1Q24 earnings would fall in 2Q24.

Source: AlphaWise, Morgan Stanley Research

Exhibit 204: Automation Mentions Across the S&P 500 Over the Past 4 Quarters by Sector.



Source: AlphaWise, Morgan Stanley Research

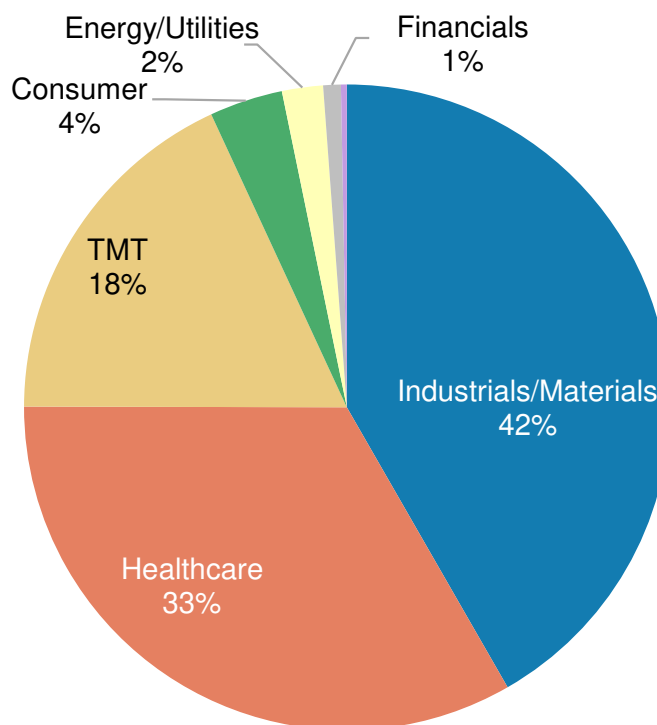
Exhibit 205: Top 25 Companies Mentioning Robotics Over the Past 4 Quarters (3Q23 - 2Q24)

Robotics-Specific Mentions in Past 4 Quarters							
Rank	Mentions	Ticker	Mkt Cap (\$mn)	Company Name	Industry	Broader Sector	
1	111	TER.O	19,141	Teradyne, Inc.	Electronic Production Equipment	Industrials/Materials	
2	76	TSLA.O	548,446	Tesla, Inc.	Motor Vehicles	Industrials/Materials	
3	62	ISRG.O	136,721	Intuitive Surgical, Inc.	Medical Specialties	Healthcare	
4	62	SYK.N	126,041	Stryker Corporation	Medical Specialties	Healthcare	
5	51	AXON.O	23,326	Axon Enterprise Inc	Aerospace & Defense	Industrials/Materials	
6	38	MDT.N	109,891	Medtronic Plc	Medical Specialties	Healthcare	
7	23	JNJ.N	360,641	Johnson & Johnson	Pharmaceuticals: Major	Healthcare	
8	20	FFIV.O	10,025	F5, Inc.	Packaged Software	TMT	
9	19	AKAM.O	15,526	Akamai Technologies, Inc.	Data Processing Services	TMT	
10	19	ZBH.N	24,984	Zimmer Biomet Holdings, Inc.	Medical Specialties	Healthcare	
11	17	NVDA.O	2,218,675	NVIDIA Corporation	Semiconductors	TMT	
12	12	TDY.N	18,619	Teledyne Technologies Incorporated	Aerospace & Defense	Industrials/Materials	
13	12	ZBRA.O	16,274	Zebra Technologies Corporation Class A	Computer Processing Hardware	TMT	
14	10	CMG.N	88,800	Chipotle Mexican Grill, Inc.	Restaurants	Consumer	
15	8	LYV.N	22,457	Live Nation Entertainment, Inc.	Movies/Entertainment	TMT	
16	7	BDX.N	67,917	Becton, Dickinson and Company	Medical Specialties	Healthcare	
17	6	ROK.N	30,838	Rockwell Automation, Inc.	Electrical Products	Industrials/Materials	
18	6	UPS.N	107,995	United Parcel Service, Inc. Class B	Air Freight/Couriers	Industrials/Materials	
19	5	AMZN.O	1,972,056	Amazon.com, Inc.	Internet Retail	TMT	
20	5	CSGP.O	37,298	CoStar Group, Inc.	Internet Software/Services	TMT	
21	5	GEHC.O	37,763	GE Healthcare Technologies Inc.	Medical Specialties	Healthcare	
22	5	LRCX.O	118,653	Lam Research Corporation	Industrial Machinery	Industrials/Materials	
23	5	POOL.O	14,297	Pool Corporation	Wholesale Distributors	Consumer	
24	4	AES.N	14,206	AES Corporation	Electric Utilities	Energy/Utilities	
25	4	DXC.N	3,588	DXC Technology Co.	Data Processing Services	TMT	

Note: Includes mentions of words such as "Robot," "Robotic," "Drone," etc. Refers to quarter that transcript took place. For example, 1Q24 earnings would fall in 2Q24.

Source: AlphaWise, Morgan Stanley Research

Exhibit 206: Robotics Mentions Across the S&P 500 Over the Past 4 Quarters by Sector.



Source: AlphaWise, Morgan Stanley Research

## Appendix III — The Case for Tesla as an AI Enabler

**"Optimus obviously is a very new product, an extremely revolutionary product and something that I think has the potential to far exceed the value of everything else at Tesla combined."**

— Elon Musk, Tesla 4Q 2023 Earnings Call

In this section, we assess the characteristics that render Tesla an enabler and differentiated competitor in the race toward humanoid labor disruption, with in-house custom silicon efforts tailored to the Tesla use case, a high-quality and exponentially growing data set, a heavy global manufacturing footprint consisting of "disrupt-able" labor, vertically integrated hardware and software, best in class talent, a strong balance sheet with access to capital, and *an existing fleet of sensor encrusted robots already making life or death decisions in highly unpredictable environment (every Tesla vehicle on the road).*

We note that our \$310 price target for Tesla is comprised of auto (hardware), auto-related (software, services) and energy-related businesses. While Tesla's competencies in computer vision, machine learning, AI and robotics may have a multitude of adjacent commercial applications, we have not included such revenue streams (including Optimus) in our model or valuation at this time.

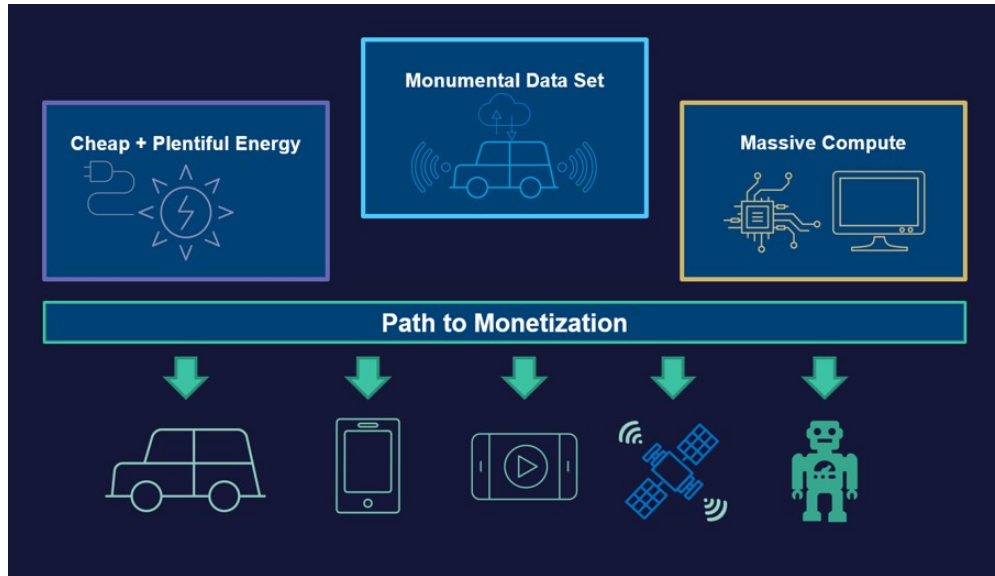
**We've previously written that in the journey to AI "supremacy," there are a number of attributes and gating factors that investors are increasingly locked in on:**

- 1. Data.** Tesla recently achieved **1bn miles traveled** for its full self-driving (FSD) service. Tesla's fleet drives more miles in 5 minutes than Apple's (now cancelled) autonomous fleet had **reportedly driven in a year**. By 2030, we estimate Tesla's global vehicle fleet will approach 40 million units in service, driving over 400 billion miles per year. Over 1 billion miles per day or nearly 13 thousand miles per second. From our conversations with AI experts, such a "monumental" dataset may be an advantage for machine learning and neural net training.
- 2. Compute.** As noted in our deep dive on Tesla's in-house computing effort (**Dojo**), Tesla has predicted that they will reach 100 exaFLOPs of compute by 4Q24, up from ~4.5 today (as of 3Q23). According to Tesla, that's the equivalent of ~300,000 A100 GPUs, which on our estimates would cost \$7.5-8.0 billion. Whether the 100 exaFLOP goal becomes reality by then or not, the company would either need to ramp up its in-house Dojo compute capability or substantially increase purchases of Nvidia GPU clusters. **With this in mind, we found Morgan Stanley US Semis analyst Joe Moore's channel checks on Nvidia quite insightful: "We continue to hear reports of stronger demand outside of the traditional hyperscaler customers, with notably robust demand from Tesla,** and a wide range of sovereign customers (which remain difficult to triangulate and verify but which, by all accounts, are a strong source of incremental demand)." On our calculations from last year, we had encountered scenarios where Tesla could end up being among Nvidia's very largest customers in the future. At what point will the 'yottaflop' (10<sup>24</sup> floating operations/sec) enter the collective consciousness?
- 3. Energy.** Our electric utility and thematics team have been highlighting to investors the **significant mismatch** between the hyper-rapid growth in GenAI power needs (notwithstanding continued efficiency improvements) and the slow growth in power grid infrastructure. While there are many chapters left to play out, Tesla's access to large amounts of low-cost electricity may prove to be one of the most deterministic advantages in Tesla's growing AI portfolio. We value Tesla Energy at \$38/share to Tesla but this may not capture the strategic value of Tesla's fast-growing US renewable energy ecosystem (Tesla Energy and Storage revenues were up 54% YoY in FY23).
- 4. Path to monetization.** Tesla's highly anticipated August 8 **Robotaxi day** may offer some important clues as to the ongoing business model shift and change of emphasis away from the increasingly over-supplied EV industry. However, we anticipate it may be difficult for Tesla to convince investors of the ability to achieve commercial scale under a timeline relevant to most investors. As for the Full-Self-Driving campaign, we expect improvements here to be non-linear and difficult to predict. While not claiming perfection, Tesla has described this upcoming FSD version as its "ChatGPT moment" in terms of delivering a major step change improve-

ment in performance of the system (without labeling, without LiDAR, and without HD maps). Having said that, we

are concerned at the margin of the level of enthusiasm among some investors around the improvements of the FSD v12.

**Exhibit 207:** Tesla's Potential Advantages in the Race to AI "Supremacy"

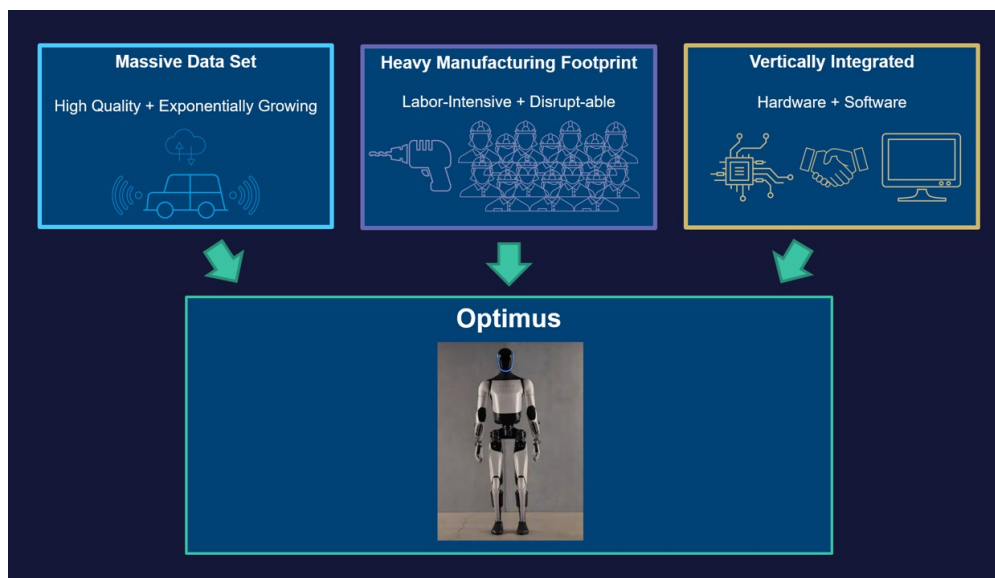


Source: Morgan Stanley Research

Consequently, Tesla is uniquely positioned to both enable and benefit from humanoids in our view. Inspired by NVIDIA CEO Jensen Huang's March 2024 [CNBC interview](#), we summarize three key factors supporting the Tesla 'AI Enabler' case:

1. **Massive data set that is both *high quality* (edge cases from unique driving situations) and *continuously growing at an accelerating pace* (constantly collecting data from increasing miles driven across growing car parc).**
2. **Massive global manufacturing footprint with labor-intensive processes that are relatively simple to replicate via automation, which creates the opportunity to "observe" and collect data from its own workers to train bots (and continuously iterate upon that pattern).**
3. **Experience in vertically integrating key hardware and software infrastructure.**

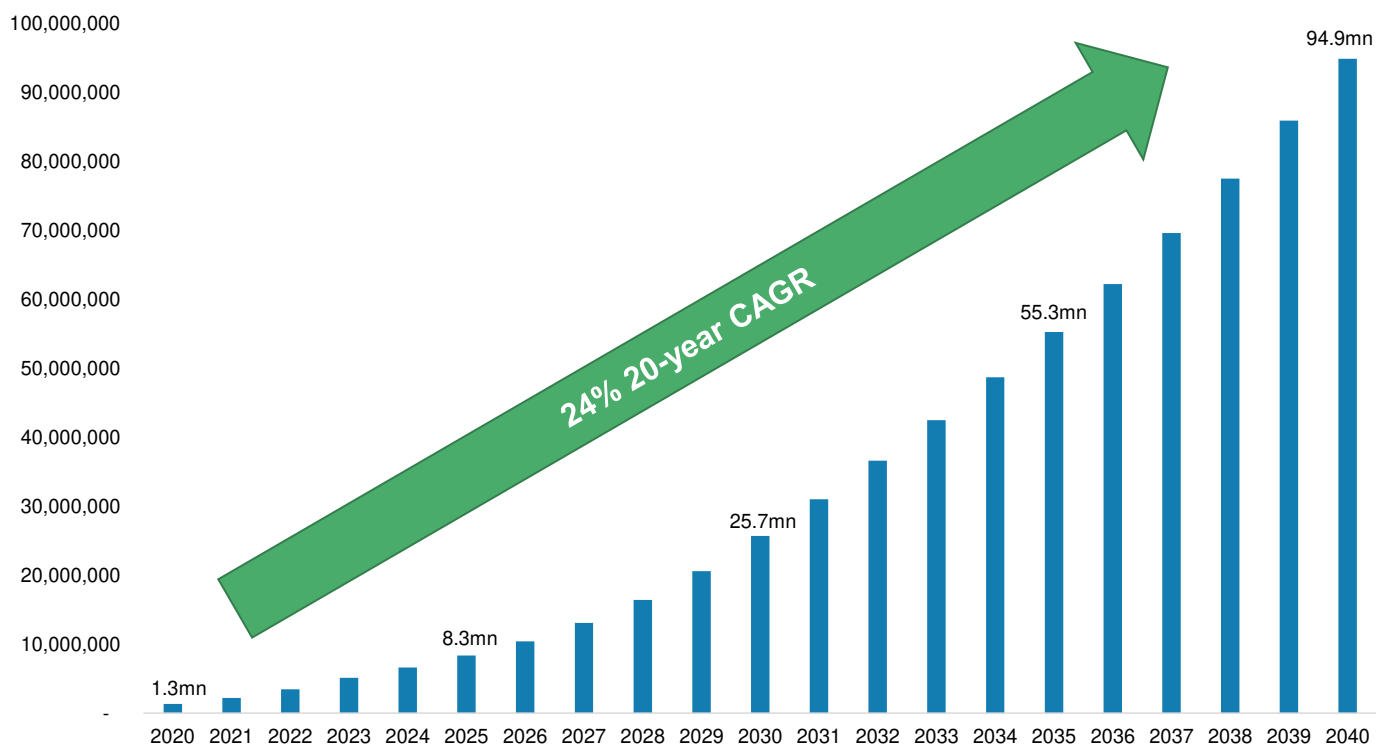
**Exhibit 208:** Tesla is Uniquely Positioned to Both Enable and Benefit from Humanoids



Source: Morgan Stanley Research

**Tesla's cars are sensor encrusted robots making life and death decisions in highly unpredictable environments and driving situations.** Tesla's ability to improve the efficacy of its full self driving system is limited primarily by the ability to collect and process real world video data from the edge and to train these robots from the experience of its vehicle fleet in service, which is 5mn units today and closer to 24 million by end of decade, on our estimates.

**Exhibit 209:** Tesla Car Parc (MSe)

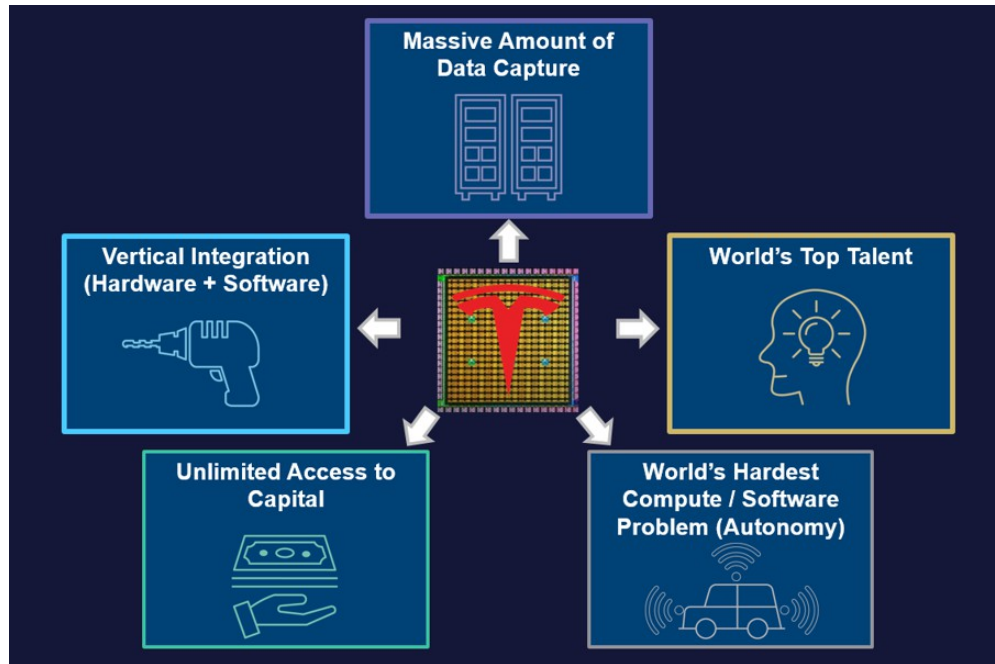


Source: Morgan Stanley Research

**In its quest to "solve" autonomy, Tesla has developed an advanced supercomputing architecture, Dojo, that pushes new boundaries in custom silicon and may put Tesla at an asymmetric advantage in a \$10 trillion TAM.** Tesla is in the process of building out Dojo functionality for both training and inference to supplement and diversify from over-reliance on NVIDIA GPUs (we estimate that if Tesla were to rely solely on NVIDIA to reach their stated compute power goal, they alone could comprise 6-11% of NVIDIA's revenue). Regardless of Dojo progress (Tesla is [not the first player](#) to attempt in-house custom silicon), Tesla maintains a unique position to "solve" the quest for autonomous labor.

**What's unique about Tesla is the company's access and scale.** Like other tech platforms, Tesla pursues high vertical integration in key technology domains to enable high iteration and continual improvement while helping to diversify away from over-reliance on 3rd party suppliers that may not be able to provide an optimal solution for Tesla's specific needs. Tesla is not the only player with a massive manufacturing base or access to data and capital, but the confluence of each factor — a vast network of vehicles that is constantly increasing (400k+ FSDs on the road (figure last reported January 2023) already collecting data from 300+ million miles traveled coupled with ~140k employees across a global manufacturing base), a world class design team, and expansive resources allocated toward 'solving' the autonomy problem — puts Tesla in a very strong position in the race for humanoids.

**Exhibit 210:** Tesla's capabilities and business model can significantly benefit from the development of custom AI tools. It's too big and too specialized an opportunity not to have in-house.



Source: Morgan Stanley Research

**The autonomous car has been described as the mother of all AI projects — humanoids are a natural extension.** The "brain" for the humanoid bot will be informed by the same autonomous systems present in Tesla's vehicles. There is natural crossover between autonomous labor (Optimus) and driving (FSD): both require the ability to process raw video input as well as the function to generate 3D maps to inform the user to react to perceived objects (Occupancy Network). Additionally, the commercialization of humanoids like Optimus may be faster than full robotaxi or L5 autonomous driven because it inherently involves less of a safety concern given they are geofenced to warehouses/factory floors within work cell boundaries.

*The development and refinement of Optimus, like FSD for Tesla vehicles, can be exponentially accelerated by the speed with which Tesla can train its vision-based neural net.*

**"What really matters to accelerate a sustainable future is being able to scale up production volume as quickly as possible. That is why Tesla engineering has transitioned to focus heavily on designing the machine that makes the machine — turning the factory itself into a product."**

Tesla CEO Elon Musk, July 2016

Successful robotic assistance in the production line could result in systematic cost reductions and alleviate labor shortages long-term. We remind investors that there are far bigger forces at work here on the interplay of labor demographics, education, immigration, union organization and other factors. Energy transition and on-shoring industrial manufacturing significantly accelerate the pay-backs, trade-offs and social implications of human replacement behind the wheel, in the mine, at the warehouse and on the factory floor.

**That being said, we do not ascribe any value to Optimus, either as a "line item" or via potentially realized cost savings in our Tesla model (and would discourage investors from doing the same) at this time.**

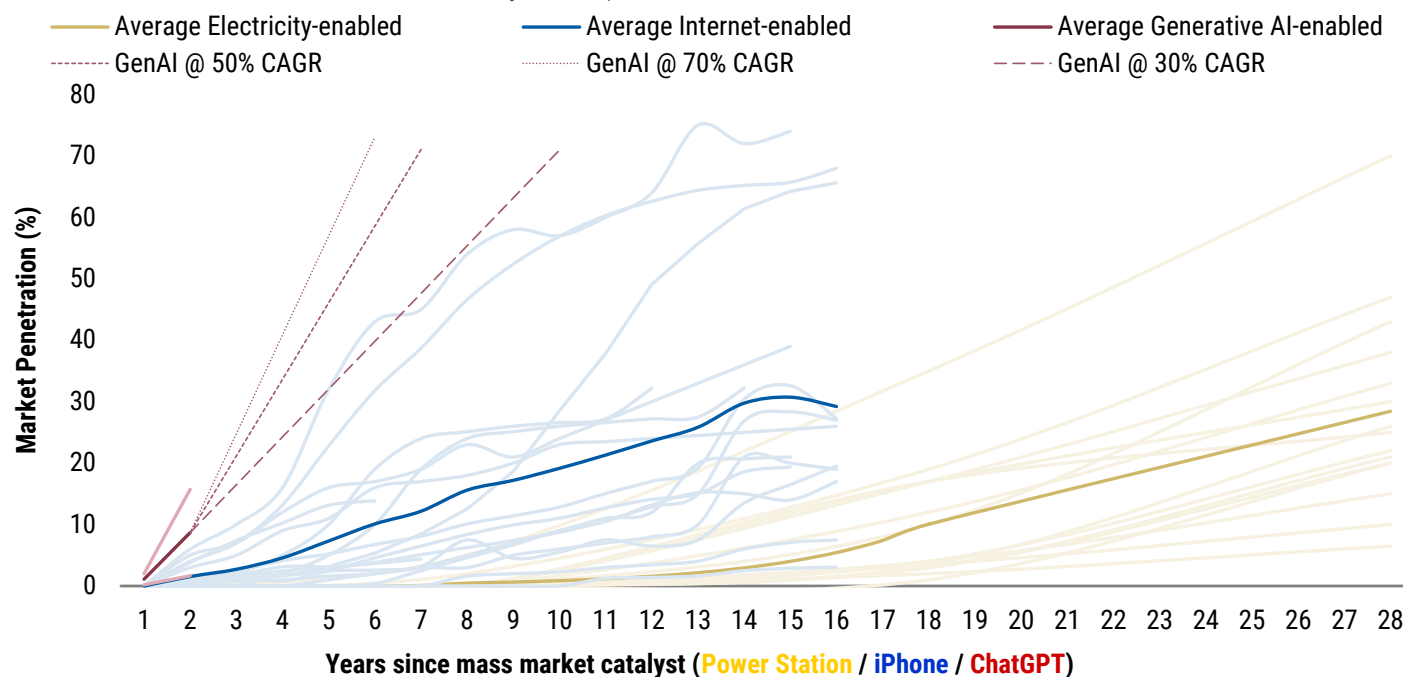


# Appendix IV — Domestic Robotics: Moonshots

## Global Thematics

### Moonshots

Exhibit 211: Generative AI vs internet vs electricity market penetration

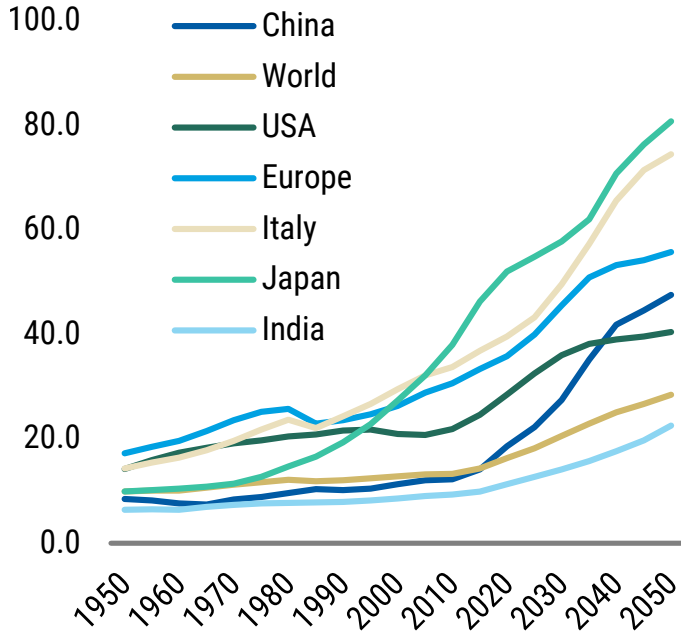


Source: OurWorldinData, Morgan Stanley Research

**If necessity is the mother of all invention, then nowhere is this more true than in the field of domestic robotics.** The world is aging and consequently dependency ratios are rising at an unprecedented pace. Within the coming 10 years — particularly driven by Asian nations - innovation will be required to perform the role that children and grandchildren once did. *When we say domestic robotics, we do not mean IoT connected vacuum cleaners in our homes doing "smart" cleaning. We mean anthropomorphic robotics engaging in physical labor.*

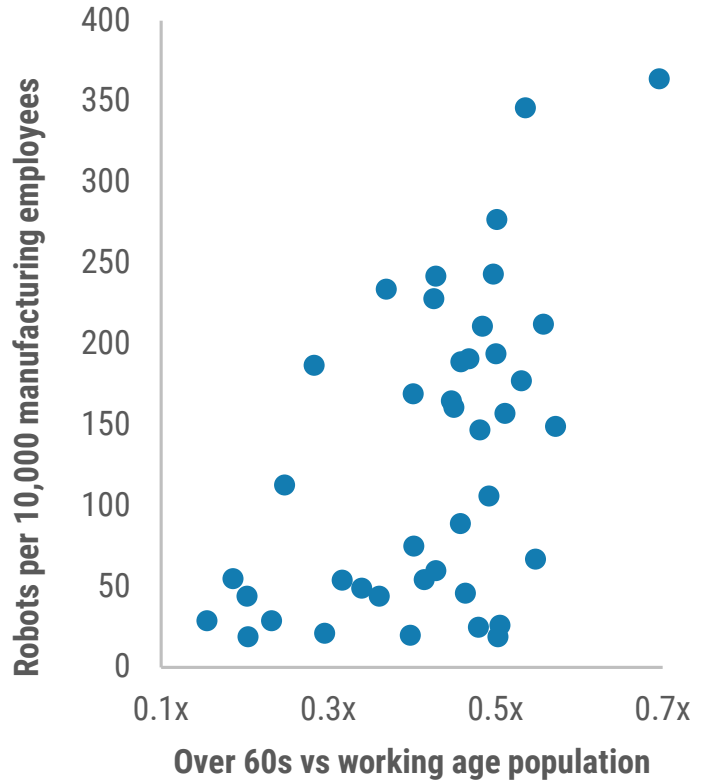
**Innovation in domestic robotics is occurring across a handful of companies (albeit largely each sticking their separate niche) in (1) natural mobility, (2) robustness of design, (3) social engagement using open source AI tools like GPT-3, (4) hyper-realistic facial functions, and (5) self-learning and correction in unprogrammed environments.** Improvement in function and reduction in cost over the past 5 years have been exponential. Using the analogy of the timeline for personal computers, we are in the 1980s for domestic robots. Over the coming 20 years we are likely to see an enormous proliferation of robotics outside the factory.

**Exhibit 212:** Dependency ratio by region



Source: United Nations, MS Research

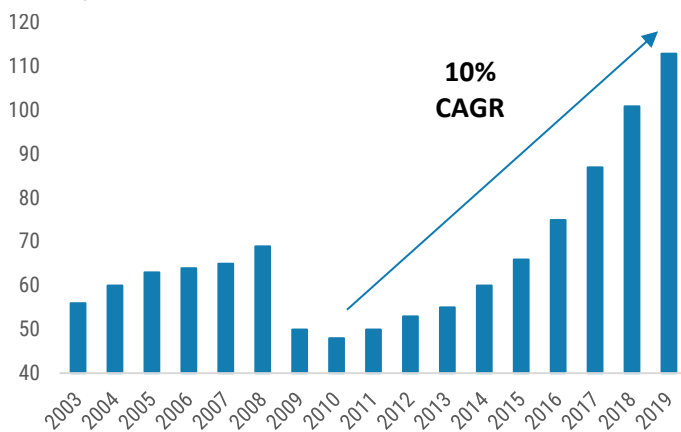
**Exhibit 213:** Industrial Robot penetration vs. Dependency ratio



Source: IFR, Morgan Stanley Research

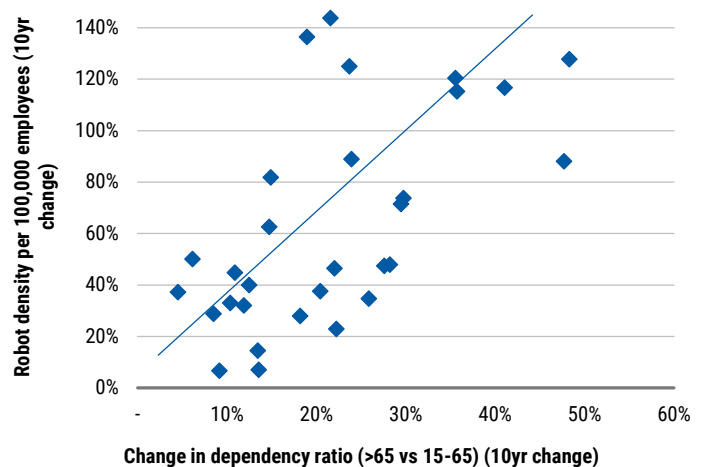
**There is no doubt that as costs have fallen and functionality of industrial multi-purpose robots/co-bots has improved, so too has demand for them.** However, there are also relationships between robotic installations vs. GDP growth and export dependency — albeit not always strong correlations. The relationship that interests us most is robotic installed base versus a nation's dependency ratio (>65 relative to 15-65 age groups). As all nations age, industrial robotic R&D is giving way to domestic robotic R&D. In time, we think domestic robots will be a must-have rather than a nice-to-have.

**Exhibit 214:** Robot penetration — number of multipurpose industrial robots per 10,000 persons employed in the manufacturing industry



Source: IFR, Morgan Stanley Research

**Exhibit 215:** Industrial robot density per manufacturing employee vs. changing dependency ratio by nation



Source: IFR, Morgan Stanley Research

# Appendix V — Payback Analysis Excel Backup

**Exhibit 216:** Payback Analysis (1)

Case Control				Humanoid Replacement Rate Control															
		Base																	
Active Case		1																	
Case	#	Cost Per Humanoid (\$k)	Useful Life (Years)																
Base	1	50	10																
Bear	2	100	5																
Bull	3	25	20																
								0		10		20		30		40		50	
								0		5		10		15		20		25	
								0		20		40		60		80		100	
Humanoid Cost Per Year (\$k)																			
Years Since Initial				0		5		10		15		20							
#	Industry	Cost Per Humanoid	2030	2035	2040	2045	2050												
1	Food Preparation and Serving Related	50	50	0	50	0	50												
2	Transportation and Material Moving	50	50	0	50	0	50												
3	Production	50	50	0	50	0	50												
4	Sales and Related	50	50	0	50	0	50												
5	Healthcare Support	50	50	0	50	0	50												
6	Office and Administrative Support	50	50	0	50	0	50												
7	Construction and Extraction	50	50	0	50	0	50												
8	Installation, Maintenance, and Repair	50	50	0	50	0	50												
9	Healthcare Practitioners and Technical	50	50	0	50	0	50												
10	Building and Grounds Cleaning and Maintenance	50	50	0	50	0	50												
11	Educational Instruction and Libraries	50	50	0	50	0	50												
12	Protective Service	50	50	0	50	0	50												
13	Personal Care and Service	50	50	0	50	0	50												
14	Management	50	50	0	50	0	50												
15	Architecture and Engineering	50	50	0	50	0	50												
16	Business and Financial Operations	50	50	0	50	0	50												
17	Life, Physical, and Social Science	50	50	0	50	0	50												
18	Farming, Fishing, and Forestry	50	50	0	50	0	50												
19	Arts, Design, Entertainment, Sports, and Media	50	50	0	50	0	50												
20	Community and Social Service	50	50	0	50	0	50												
21	Legal	50	50	0	50	0	50												
22	Computer and Mathematical	50	50	0	50	0	50												
Human Laborer Cost Per Year (\$k)																			
Years Since Initial				0		5		10		15		20							
#	Industry	Cost Per Human	2030	2035	2040	2045	2050												
1	Food Preparation and Serving Related	35	35	35	35	35	35												
2	Transportation and Material Moving	58	58	58	58	58	58												
3	Production	47	47	47	47	47	47												
4	Sales and Related	55	55	55	55	55	55												
5	Healthcare Support	43	43	43	43	43	43												
6	Office and Administrative Support	46	46	46	46	46	46												
7	Construction and Extraction	54	54	54	54	54	54												
8	Installation, Maintenance, and Repair	56	56	56	56	56	56												
9	Healthcare Practitioners and Technical	98	98	98	98	98	98												
10	Building and Grounds Cleaning and Maintenance	43	43	43	43	43	43												
11	Educational Instruction and Libraries	75	75	75	75	75	75												
12	Protective Service	57	57	57	57	57	57												
13	Personal Care and Service	38	38	38	38	38	38												
14	Management	109	109	109	109	109	109												
15	Architecture and Engineering	89	89	89	89	89	89												
16	Business and Financial Operations	76	76	76	76	76	76												
17	Life, Physical, and Social Science	84	84	84	84	84	84												
18	Farming, Fishing, and Forestry	44	44	44	44	44	44												
19	Arts, Design, Entertainment, Sports, and Media	63	63	63	63	63	63												
20	Community and Social Service	54	54	54	54	54	54												
21	Legal	90	90	90	90	90	90												
22	Computer and Mathematical	104	104	104	104	104	104												

Source: Bureau of Labor Statistics, Morgan Stanley Research

Note: The above displays the base case, in which we assume an average cost per humanoid of \$50k and a useful life of 10 years. To view outputs for the bull (\$25k cost, 20-year useful life) and bear (\$100k cost, 5-year useful life) cases, please request our TAM model.

Exhibit 217: Payback Analysis (2)

Cumulative Humanoid Cost (\$k)							
Years Since Initial		0	5	10	15	20	
#	Industry	Cost Per Humanoid	2030	2035	2040	2045	2050
1	Food Preparation and Serving Related	50	50	50	100	100	150
2	Transportation and Material Moving	50	50	50	100	100	150
3	Production	50	50	50	100	100	150
4	Sales and Related	50	50	50	100	100	150
5	Healthcare Support	50	50	50	100	100	150
6	Office and Administrative Support	50	50	50	100	100	150
7	Construction and Extraction	50	50	50	100	100	150
8	Installation, Maintenance, and Repair	50	50	50	100	100	150
9	Healthcare Practitioners and Technical	50	50	50	100	100	150
10	Building and Grounds Cleaning and Maintenance	50	50	50	100	100	150
11	Educational Instruction and Libraries	50	50	50	100	100	150
12	Protective Service	50	50	50	100	100	150
13	Personal Care and Service	50	50	50	100	100	150
14	Management	50	50	50	100	100	150
15	Architecture and Engineering	50	50	50	100	100	150
16	Business and Financial Operations	50	50	50	100	100	150
17	Life, Physical, and Social Science	50	50	50	100	100	150
18	Farming, Fishing, and Forestry	50	50	50	100	100	150
19	Arts, Design, Entertainment, Sports, and Media	50	50	50	100	100	150
20	Community and Social Service	50	50	50	100	100	150
21	Legal	50	50	50	100	100	150
22	Computer and Mathematical	50	50	50	100	100	150

Cumulative Human Laborer Cost (\$k)							
Years Since Initial		0	5	10	15	20	
#	Industry	Cost Per Human	2030	2035	2040	2045	2050
1	Food Preparation and Serving Related	35	35	175	350	524	699
2	Transportation and Material Moving	58	58	290	580	870	1,159
3	Production	47	47	236	471	707	942
4	Sales and Related	55	55	275	550	825	1,100
5	Healthcare Support	43	43	216	432	648	864
6	Office and Administrative Support	46	46	228	456	684	912
7	Construction and Extraction	54	54	269	538	806	1,075
8	Installation, Maintenance, and Repair	56	56	282	564	846	1,128
9	Healthcare Practitioners and Technical	98	98	491	981	1,472	1,962
10	Building and Grounds Cleaning and Maintenance	43	43	214	428	642	856
11	Educational Instruction and Libraries	75	75	373	746	1,118	1,491
12	Protective Service	57	57	286	571	857	1,142
13	Personal Care and Service	38	38	192	385	577	770
14	Management	109	109	547	1,093	1,640	2,186
15	Architecture and Engineering	89	89	443	885	1,328	1,771
16	Business and Financial Operations	76	76	380	759	1,139	1,518
17	Life, Physical, and Social Science	84	84	418	836	1,255	1,673
18	Farming, Fishing, and Forestry	44	44	219	439	658	878
19	Arts, Design, Entertainment, Sports, and Media	63	63	313	626	939	1,251
20	Community and Social Service	54	54	268	536	804	1,073
21	Legal	90	90	448	896	1,344	1,793
22	Computer and Mathematical	104	104	521	1,041	1,562	2,082

Cumulative Wage Differential, Per Human Laborer (\$k)								
Years Since Initial		0	5	10	15	20		
#	Industry	Human Annual Wage (\$k)	Humanoid Cost (\$k)	Cumulative Humoid Cost - Cumulative Human Cost, \$k				
				2030	2035	2040	2045	2050
1	Food Preparation and Serving Related	35	50	-15	125	250	424	549
2	Transportation and Material Moving	58	50	8	240	480	770	1,009
3	Production	47	50	-3	186	371	607	792
4	Sales and Related	55	50	5	225	450	725	950
5	Healthcare Support	43	50	-7	166	332	548	714
6	Office and Administrative Support	46	50	-4	178	356	584	762
7	Construction and Extraction	54	50	4	219	438	706	925
8	Installation, Maintenance, and Repair	56	50	6	232	464	746	978
9	Healthcare Practitioners and Technical	98	50	48	441	881	1,372	1,812
10	Building and Grounds Cleaning and Maintenance	43	50	-7	164	328	542	706
11	Educational Instruction and Libraries	75	50	25	323	646	1,018	1,341
12	Protective Service	57	50	7	236	471	757	992
13	Personal Care and Service	38	50	-12	142	285	477	620
14	Management	109	50	59	497	993	1,540	2,036
15	Architecture and Engineering	89	50	39	393	785	1,228	1,621
16	Business and Financial Operations	76	50	26	330	659	1,039	1,368
17	Life, Physical, and Social Science	84	50	34	368	736	1,155	1,523
18	Farming, Fishing, and Forestry	44	50	-6	169	339	558	728
19	Arts, Design, Entertainment, Sports, and Media	63	50	13	263	526	839	1,101
20	Community and Social Service	54	50	4	218	436	704	923
21	Legal	90	50	40	398	796	1,244	1,643
22	Computer and Mathematical	104	50	54	471	941	1,462	1,932

Source: Bureau of Labor Statistics, Morgan Stanley Research  
 Note: The above displays the base case, in which we assume an average cost per humanoid of \$50k and a useful life of 10 years. To view outputs for the bull (\$25k cost, 20-year useful life) and bear (\$100k cost, 5-year useful life) cases, please request our TAM model.

## Disclosure Section

The information and opinions in Morgan Stanley Research were prepared or are disseminated by Morgan Stanley & Co. LLC and/or Morgan Stanley C.T.V.M. S.A. and/or Morgan Stanley México, Casa de Bolsa, S.A. de C.V. and/or Morgan Stanley Canada Limited and/or Morgan Stanley & Co. International plc and/or Morgan Stanley Europe S.E. and/or RMB Morgan Stanley Proprietary Limited and/or Morgan Stanley MUFG Securities Co., Ltd. and/or Morgan Stanley Capital Group Japan Co., Ltd. and/or Morgan Stanley Asia Limited and/or Morgan Stanley Asia (Singapore) Pte. (Registration number 199206298Z) and/or Morgan Stanley Asia (Singapore) Securities Pte Ltd (Registration number 200008434H), regulated by the Monetary Authority of Singapore (which accepts legal responsibility for its contents and should be contacted with respect to any matters arising from, or in connection with, Morgan Stanley Research) and/or Morgan Stanley Taiwan Limited and/or Morgan Stanley & Co International plc, Seoul Branch, and/or Morgan Stanley Australia Limited (A.B.N. 67 003 734 576, holder of Australian financial services license No. 233742, which accepts responsibility for its contents), and/or Morgan Stanley Wealth Management Australia Pty Ltd (A.B.N. 19 009 145 555, holder of Australian financial services license No. 240813, which accepts responsibility for its contents), and/or Morgan Stanley India Company Private Limited having Corporate Identification No (CIN) U22990MH1998PTC115305, regulated by the Securities and Exchange Board of India ("SEBI") and holder of licenses as a Research Analyst (SEBI Registration No. INH000001105), Stock Broker (SEBI Stock Broker Registration No. INZ000244438), Merchant Banker (SEBI Registration No. INM000011203), and depository participant with National Securities Depository Limited (SEBI Registration No. IN-DP-NSDL-567-2021) having registered office at 18th Floor, Tower 2, One World Center, Plot- 841, Jupiter Textile Mill Compound, Senapati Bapat Marg, Lower Parel, Mumbai 400013, India Telephone no. +91-22-61181000; Compliance Officer Details: Mr. Tejarshi Hardas, Tel. No.: +91-22-61181000 or Email: tejarshi.hardas@morganstanley.com; Grievance officer details: Mr. Tejarshi Hardas, Tel. No.: +91-22-61181000 or Email: msic-compliance@morganstanley.com which accepts the responsibility for its contents and should be contacted with respect to any matters arising from, or in connection with, Morgan Stanley Research, and their affiliates (collectively, "Morgan Stanley").

For important disclosures, stock price charts and equity rating histories regarding companies that are the subject of this report, please see the Morgan Stanley Research Disclosure Website at [www.morganstanley.com/researchdisclosures](http://www.morganstanley.com/researchdisclosures), or contact your investment representative or Morgan Stanley Research at 1585 Broadway, (Attention: Research Management), New York, NY, 10036 USA.

For valuation methodology and risks associated with any recommendation, rating or price target referenced in this research report, please contact the Client Support Team as follows: US/Canada +1 800 303-2495; Hong Kong +852 2848-5999; Latin America +1 718 754-5444 (U.S.); London +44 (0)20-7425-8169; Singapore +65 6834-6860; Sydney +61 (0)2-9770-1505; Tokyo +81 (0)3-6836-9000. Alternatively you may contact your investment representative or Morgan Stanley Research at 1585 Broadway, (Attention: Research Management), New York, NY 10036 USA.

### Analyst Certification

The following analysts hereby certify that their views about the companies and their securities discussed in this report are accurately expressed and that they have not received and will not receive direct or indirect compensation in exchange for expressing specific recommendations or views in this report: Stephen C Byrd; Brian Harbour, CFA; Bas R Jaspers; Lisa Jiang; Adam Jonas, CFA; Daniel Kutz; Joe Laetsch, CFA; Kristine T Liwag; Devin McDermott; Joseph Moore; Brian Nowak, CFA; Matias Ovrum; Ariana Salvatore; Ravi Shanker; Edward Stanley; Chelsea Wang; Shelley Wang, CFA; Sheng Zhong.

### Global Research Conflict Management Policy

Morgan Stanley Research has been published in accordance with our conflict management policy, which is available at [www.morganstanley.com/institutional/research/conflict/policies](http://www.morganstanley.com/institutional/research/conflict/policies). A Portuguese version of the policy can be found at [www.morganstanley.com.br](http://www.morganstanley.com.br)

### Important Regulatory Disclosures on Subject Companies

The analyst or strategist (or a household member) identified below owns the following securities (or related derivatives): Matt Bombassei - NVIDIA Corp.(common or preferred stock); Julian Herrera - NVIDIA Corp.(common or preferred stock); Adam Jonas, CFA - Amazon.com Inc(common or preferred stock), Dominos Pizza Inc.(common or preferred stock); Joe Laetsch, CFA - Amazon.com Inc(common or preferred stock); Kristine T Liwag - NVIDIA Corp.(common or preferred stock); Devin McDermott - McDonald's Corporation(common or preferred stock), NXP Semiconductor NV(common or preferred stock); Matt Moros - Amazon.com Inc(common or preferred stock), NVIDIA Corp.(common or preferred stock); Brian Nowak, CFA - ARM Holdings PLC(GDR), NVIDIA Corp.(common or preferred stock); Matias Ovrum - Amazon.com Inc(common or preferred stock); Ariana Salvatore - Tesla Inc(common or preferred stock); Edward Stanley - NVIDIA Corp.(common or preferred stock); Stanley Wang - Amazon.com Inc(common or preferred stock), McDonald's Corporation(common or preferred stock).

As of May 31, 2024, Morgan Stanley beneficially owned 1% or more of a class of common equity securities of the following companies covered in Morgan Stanley Research: Amazon.com Inc, Ambarella Inc, Baker Hughes Co, BMW, BYD Company Limited, Cadence Design Systems Inc, Coupang Inc, DHL Group, Dominos Pizza Inc., DSV A/S, Ford Motor Company, General Motors Company, Haidilao International Holding Ltd, Halliburton Co, Hexagon AB, Infineon Technologies AG, JD.com, Inc., Knight-Swift Transportation Holdings Inc, McDonald's Corporation, Mercedes-Benz Group AG, Naver Corp, NTN, NVIDIA Corp., NXP Semiconductor Corp., Qualcomm Inc., Schlumberger NV, Shimizu, Siemens, SK hynix, Socionext, Stellantis, STMicroelectronics NV, Synopsys Inc., Tesla Inc, TSMC, Will Semiconductor Co Ltd Shanghai, XPeng Inc..

Within the last 12 months, Morgan Stanley managed or co-managed a public offering (or 144A offering) of securities of BMW, Ford Motor Company, General Motors Company, Harmonic Drive Systems, LG Energy Solution, NSK, NTN, Obayashi, Renesas Electronics, Schlumberger NV, Socionext, Stellantis, Tesla Inc, Toyota Motor.

Within the last 12 months, Morgan Stanley has received compensation for investment banking services from Amazon.com Inc, Baker Hughes Co, BMW, DHL Group, Ford Motor Company, General Motors Company, LG Energy Solution, NSK, NTN, Obayashi, ON Semiconductor Corp., Schlumberger NV, Stellantis, Tesla Inc, Toyota Motor.

In the next 3 months, Morgan Stanley expects to receive or intends to seek compensation for investment banking services from Amazon.com Inc, Ambarella Inc, ARM Holdings PLC, Baker Hughes Co, BMW, BYD Company Limited, Cadence Design Systems Inc, Contemporary Ampere Technology Co. Ltd., Coupang Inc, Dassault Systemes SA, DHL Group, Dominos Pizza Inc., DSV A/S, Ford Motor Company, General Motors Company, GS Retail Co Ltd, Haidilao International Holding Ltd, Halliburton Co, Harmonic Drive Systems, Hexagon AB, Infineon Technologies AG, JD.com, Inc., Kuehne und Nagel International AG, LG Energy Solution, McDonald's Corporation, Mercedes-Benz Group AG, Mobileye Global Inc, Naver Corp, NSK, NTN, NVIDIA Corp., NXP Semiconductor NV, Obayashi, ON Semiconductor Corp., Qualcomm Inc., Renesas Electronics, Samsung Electronics, Samsung SDI, Schlumberger NV, Shimizu, Siemens, SK hynix, SK Innovation Co Ltd, Socionext, Stellantis, STMicroelectronics NV, Synopsys Inc., Taisei, Tesla Inc, Toyota Motor, TSMC, Werner Enterprises, XPeng Inc..

Within the last 12 months, Morgan Stanley has received compensation for products and services other than investment banking services from Amazon.com Inc, Baker Hughes Co, BMW, BYD Company Limited, Cadence Design Systems Inc, China State Construction Engineering, Dassault Systemes SA, DHL Group, Dominos Pizza Inc., Ford Motor Company, General Motors Company, Haidilao International Holding Ltd, Halliburton Co, Hexagon AB, Infineon Technologies AG, McDonald's Corporation, Mercedes-Benz Group AG, NVIDIA Corp., NXP Semiconductor NV, ON Semiconductor Corp., Qualcomm Inc., Samsung SDI, Schlumberger NV, Siemens, SK Innovation Co Ltd, SMIC, Stellantis, Synopsys Inc., Taisei, Tenaris SA, Tesla Inc, Toyota Motor, TSMC, Werner Enterprises, Yum China Holdings Inc.

Within the last 12 months, Morgan Stanley has provided or is providing investment banking services to, or has an investment banking client relationship with, the following company: Amazon.com Inc, Ambarella Inc, ARM Holdings PLC, Baker Hughes Co, BMW, BYD Company Limited, Cadence Design Systems Inc, Contemporary Ampere Technology Co. Ltd., Coupang Inc, Dassault

Systemes SA, DHL Group, Dominos Pizza Inc., DSV A/S, Ford Motor Company, General Motors Company, GS Retail Co Ltd, Haidilao International Holding Ltd, Halliburton Co, Harmonic Drive Systems, Hexagon AB, Infineon Technologies AG, JD.com, Inc., Kuehne und Nagel International AG, LG Energy Solution, McDonald's Corporation, Mercedes-Benz Group AG, Mobileye Global Inc, Naver Corp, NSK, NTN, NVIDIA Corp., NXP Semiconductor NV, Obayashi, ON Semiconductor Corp., Qualcomm Inc., Renesas Electronics, Samsung Electronics, Samsung SDI, Schlumberger NV, Shimizu, Siemens, SK hynix, SK Innovation Co Ltd, Socionext, Stellantis, STMicroelectronics NV, Synopsys Inc., Taisei, Tesla Inc, Toyota Motor, TSMC, Werner Enterprises, XPeng Inc.

Within the last 12 months, Morgan Stanley has either provided or is providing non-investment banking, securities-related services to and/or in the past has entered into an agreement to provide services or has a client relationship with the following company: Amazon.com Inc, Ambarella Inc, Baker Hughes Co, BMW, BYD Company Limited, Cadence Design Systems Inc, China State Construction Engineering, Dassault Systemes SA, DHL Group, Dominos Pizza Inc., Ford Motor Company, General Motors Company, Haidilao International Holding Ltd, Halliburton Co, Harmonic Drive Systems, Hexagon AB, Infineon Technologies AG, McDonald's Corporation, Mercedes-Benz Group AG, Naver Corp, NVIDIA Corp., NXP Semiconductor NV, ON Semiconductor Corp., Qualcomm Inc., Renesas Electronics, Samsung SDI, Schlumberger NV, Siemens, SK Innovation Co Ltd, SMIC, Stellantis, Synopsys Inc., Taisei, Tenaris SA, Tesla Inc, Toyota Motor, TSMC, Werner Enterprises, Yum China Holdings Inc.

An employee, director or consultant of Morgan Stanley is a director of General Motors Company. This person is not a research analyst or a member of a research analyst's household.

Morgan Stanley & Co. LLC makes a market in the securities of Amazon.com Inc, Ambarella Inc, Baker Hughes Co, Cadence Design Systems Inc, Ford Motor Company, General Motors Company, Halliburton Co, JD.com, Inc., Knight-Swift Transportation Holdings Inc, McDonald's Corporation, Mobileye Global Inc, NVIDIA Corp., NXP Semiconductor NV, ON Semiconductor Corp., Qualcomm Inc., Schlumberger NV, Synopsys Inc., Tesla Inc, TSMC, Werner Enterprises.

The equity research analysts or strategists principally responsible for the preparation of Morgan Stanley Research have received compensation based upon various factors, including quality of research, investor client feedback, stock picking, competitive factors, firm revenues and overall investment banking revenues. Equity Research analysts' or strategists' compensation is not linked to investment banking or capital markets transactions performed by Morgan Stanley or the profitability or revenues of particular trading desks.

Morgan Stanley and its affiliates do business that relates to companies/instruments covered in Morgan Stanley Research, including market making, providing liquidity, fund management, commercial banking, extension of credit, investment services and investment banking. Morgan Stanley sells to and buys from customers the securities/instruments of companies covered in Morgan Stanley Research on a principal basis. Morgan Stanley may have a position in the debt of the Company or instruments discussed in this report. Morgan Stanley trades or may trade as principal in the debt securities (or in related derivatives) that are the subject of the debt research report.

Certain disclosures listed above are also for compliance with applicable regulations in non-US jurisdictions.

## STOCK RATINGS

Morgan Stanley uses a relative rating system using terms such as Overweight, Equal-weight, Not-Rated or Underweight (see definitions below). Morgan Stanley does not assign ratings of Buy, Hold or Sell to the stocks we cover. Overweight, Equal-weight, Not-Rated and Underweight are not the equivalent of buy, hold and sell. Investors should carefully read the definitions of all ratings used in Morgan Stanley Research. In addition, since Morgan Stanley Research contains more complete information concerning the analyst's views, investors should carefully read Morgan Stanley Research, in its entirety, and not infer the contents from the rating alone. In any case, ratings (or research) should not be used or relied upon as investment advice. An investor's decision to buy or sell a stock should depend on individual circumstances (such as the investor's existing holdings) and other considerations.

## Global Stock Ratings Distribution

(as of May 31, 2024)

The Stock Ratings described below apply to Morgan Stanley's Fundamental Equity Research and do not apply to Debt Research produced by the Firm.

For disclosure purposes only (in accordance with FINRA requirements), we include the category headings of Buy, Hold, and Sell alongside our ratings of Overweight, Equal-weight, Not-Rated and Underweight. Morgan Stanley does not assign ratings of Buy, Hold or Sell to the stocks we cover. Overweight, Equal-weight, Not-Rated and Underweight are not the equivalent of buy, hold, and sell but represent recommended relative weightings (see definitions below). To satisfy regulatory requirements, we correspond Overweight, our most positive stock rating, with a buy recommendation; we correspond Equal-weight and Not-Rated to hold and Underweight to sell recommendations, respectively.

Stock Rating Category	Coverage Universe		Investment Banking Clients (IBC)			Other Material Investment Services Clients (MISC)	
	Count	% of Total	Count	% of Total IBC	% of Rating Category	Count	% of Total Other MISC
Overweight/Buy	1455	39%	338	45%	23%	683	41%
Equal-weight/Hold	1742	46%	342	46%	20%	774	46%
Not-Rated/Hold	3	0%	0	0%	0%	1	0%
Underweight/Sell	573	15%	70	9%	12%	223	13%
Total	3,773		750			1681	

Data include common stock and ADRs currently assigned ratings. Investment Banking Clients are companies from whom Morgan Stanley received investment banking compensation in the last 12 months. Due to rounding off of decimals, the percentages provided in the "% of total" column may not add up to exactly 100 percent.

## Analyst Stock Ratings

**Overweight (O or Over)** - The stock's total return is expected to exceed the total return of the relevant country MSCI Index or the average total return of the analyst's industry (or industry team's) coverage universe, on a risk-adjusted basis over the next 12-18 months.

**Equal-weight (E or Equal)** - The stock's total return is expected to be in line with the total return of the relevant country MSCI Index or the average total return of the analyst's industry (or industry team's) coverage universe, on a risk-adjusted basis over the next 12-18 months.

**Not-Rated (NR)** - Currently the analyst does not have adequate conviction about the stock's total return relative to the relevant country MSCI Index or the average total return of the analyst's industry (or industry team's) coverage universe, on a risk-adjusted basis, over the next 12-18 months.

**Underweight (U or Under)** - The stock's total return is expected to be below the total return of the relevant country MSCI Index or the average total return of the analyst's industry (or industry team's) coverage universe, on a risk-adjusted basis, over the next 12-18 months.

Unless otherwise specified, the time frame for price targets included in Morgan Stanley Research is 12 to 18 months.



### Analyst Industry Views

Attractive (A): The analyst expects the performance of his or her industry coverage universe over the next 12-18 months to be attractive vs. the relevant broad market benchmark, as indicated below.

In-Line (I): The analyst expects the performance of his or her industry coverage universe over the next 12-18 months to be in line with the relevant broad market benchmark, as indicated below.

Cautious (C): The analyst views the performance of his or her industry coverage universe over the next 12-18 months with caution vs. the relevant broad market benchmark, as indicated below.

Benchmarks for each region are as follows: North America - S&P 500; Latin America - relevant MSCI country index or MSCI Latin America Index; Europe - MSCI Europe; Japan - TOPIX; Asia - relevant MSCI country index or MSCI sub-regional index or MSCI AC Asia Pacific ex Japan Index.

### Stock Price, Price Target and Rating History (See Rating Definitions)

BGF Retail (282330.KS) - As of 06/26/24 GMT in KRW  
Industry : S. Korea Consumer



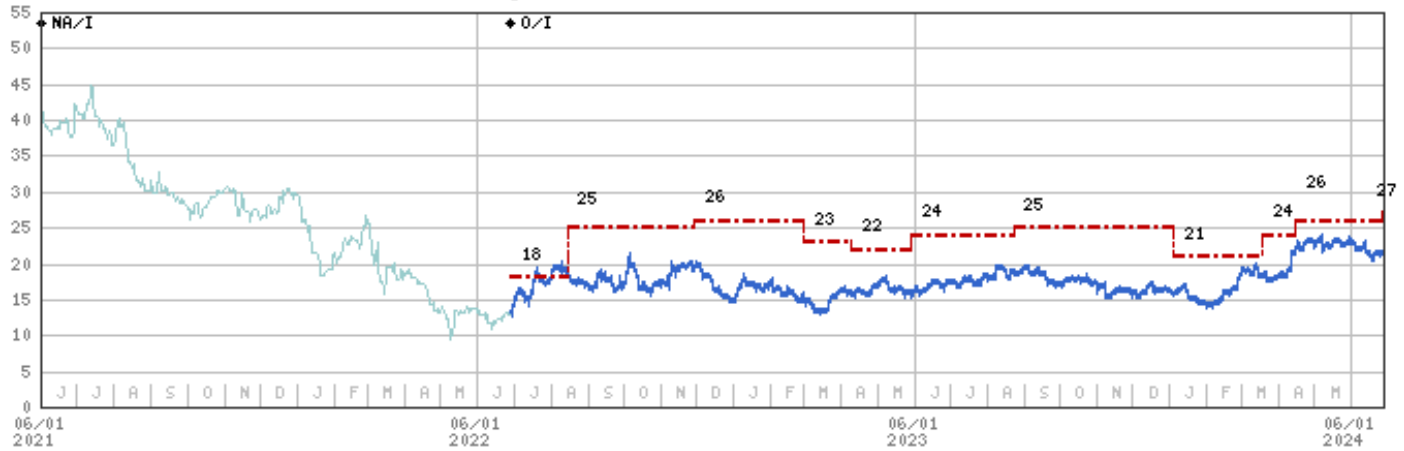
Stock Rating History: 6/1/19 : E/I; 4/21/20 : 0/I

Price Target History: 3/26/19 : 210000; 10/2/19 : 200000; 4/21/20 : 200000; 7/13/20 : 180000; 9/7/20 : 170000; 1/26/21 : 190000; 3/17/21 : 200000; 10/6/21 : 210000; 5/9/22 : 220000; 5/17/23 : 216000; 9/6/23 : 206000; 11/2/23 : 184000; 2/28/24 : 170000; 5/2/24 : 166000

Source: Morgan Stanley Research Date Format : MM/DD/YY Price Target --- No Price Target Assigned (NA)  
 Stock Price (Not Covered by Current Analyst) --- Stock Price (Covered by Current Analyst) ■  
 Stock and Industry Ratings (abbreviations below) appear as ♦ Stock Ratings/Industry View  
 Stock Ratings: Overweight (O) Equal-weight (E) Underweight (U) Not-Rated (NR) No Rating Available (NA)  
 Industry View: Attractive (A) In-line (I) Cautious (C) No Rating (NR)

Effective January 13, 2014, the stocks covered by Morgan Stanley Asia Pacific will be rated relative to the analyst's industry (or industry team's) coverage.  
 Effective January 13, 2014, the industry view benchmarks for Morgan Stanley Asia Pacific are as follows: relevant MSCI country index or MSCI sub-regional index or MSCI AC Asia Pacific ex Japan Index.

Coupage Inc (CPNG.N) - As of 06/26/24 GMT in USD  
 Industry : S. Korea Telecoms, Media & Internet



Effective January 13, 2014, the stocks covered by Morgan Stanley Asia Pacific will be rated relative to the analyst's industry (or industry team's) coverage.  
 Effective January 13, 2014, the industry view benchmarks for Morgan Stanley Asia Pacific are as follows: relevant MSCI country index or MSCI sub-regional index or MSCI AC Asia Pacific ex Japan Index.

GS Retail Co Ltd (007070.KS) - As of 06/26/24 GMT in KRW  
 Industry : S. Korea Consumer



Effective January 13, 2014, the stocks covered by Morgan Stanley Asia Pacific will be rated relative to the analyst's industry (or industry team's) coverage.  
 Effective January 13, 2014, the industry view benchmarks for Morgan Stanley Asia Pacific are as follows: relevant MSCI country index or MSCI sub-regional index or MSCI AC Asia Pacific ex Japan Index.

LG Energy Solution (373220.KS) - As of 06/26/24 GMT in KRW  
Industry : S. Korea Autos & Shared Mobility



Stock Rating History: 6/1/19 : NA/I; 3/10/22 : E/I

Price Target History: 3/10/22 : 360000; 4/4/22 : 400000; 4/27/22 : 440000; 6/16/22 : 410000; 9/2/22 : 530000; 10/26/22 : 570000; 1/3/23 : 480000; 1/30/23 : 490000; 3/10/23 : 610000; 4/26/23 : 630000; 8/25/23 : 570000; 10/4/23 : 500000; 10/25/23 : 440000; 1/5/24 : 380000; 1/29/24 : 350000; 4/5/24 : 360000

Source: Morgan Stanley Research Date Format : MM/DD/YY Price Target --- No Price Target Assigned (NA)  
Stock Price (Not Covered by Current Analyst) — Stock Price (Covered by Current Analyst) ■  
Stock and Industry Ratings (abbreviations below) appear as ♦ Stock Ratings/Industry View  
Stock Ratings: Overweight (O) Equal-weight (E) Underweight (U) Not-Rated (NR) No Rating Available (NA)  
Industry View: Attractive (A) In-line (I) Cautious (C) No Rating (NR)

Effective January 13, 2014, the stocks covered by Morgan Stanley Asia Pacific will be rated relative to the analyst's industry (or industry team's) coverage.

Effective January 13, 2014, the industry view benchmarks for Morgan Stanley Asia Pacific are as follows: relevant MSCI country index or MSCI sub-regional index or MSCI AC Asia Pacific ex Japan Index.

Lotte Shopping (023530.KS) - As of 06/26/24 GMT in KRW  
Industry : S. Korea Consumer



Stock Rating History: 6/1/19 : U/I

Price Target History: 1/21/19 : 167000; 8/10/19 : 120000; 11/8/19 : 100000; 3/24/20 : 70000; 2/9/21 : 80000; 5/11/21 : 90000; 10/6/21 : 84000; 2/8/22 : 80000; 2/15/23 : 77000; 11/10/23 : 72000; 2/8/24 : 77000; 5/10/24 : 68000

Source: Morgan Stanley Research Date Format : MM/DD/YY Price Target --- No Price Target Assigned (NA)  
Stock Price (Not Covered by Current Analyst) — Stock Price (Covered by Current Analyst) ■  
Stock and Industry Ratings (abbreviations below) appear as ♦ Stock Ratings/Industry View  
Stock Ratings: Overweight (O) Equal-weight (E) Underweight (U) Not-Rated (NR) No Rating Available (NA)  
Industry View: Attractive (A) In-line (I) Cautious (C) No Rating (NR)

Effective January 13, 2014, the stocks covered by Morgan Stanley Asia Pacific will be rated relative to the analyst's industry (or industry team's) coverage.

Effective January 13, 2014, the industry view benchmarks for Morgan Stanley Asia Pacific are as follows: relevant MSCI country index or MSCI sub-regional index or MSCI AC Asia Pacific ex Japan Index.

Naver Corp (035420.KS) - As of 06/26/24 GMT in KRW  
 Industry : S. Korea Telecoms, Media & Internet



Stock Rating History: 6/1/19 : E/I; 7/26/19 : O/I; 11/17/19 : NA/I; 2/13/20 : NA/I; 3/17/20 : NA/I; 8/3/20 : NA/I; 11/23/20 : O/I; 4/22/22 : E/I; 3/13/23 : U/I; 4/19/24 : E/I

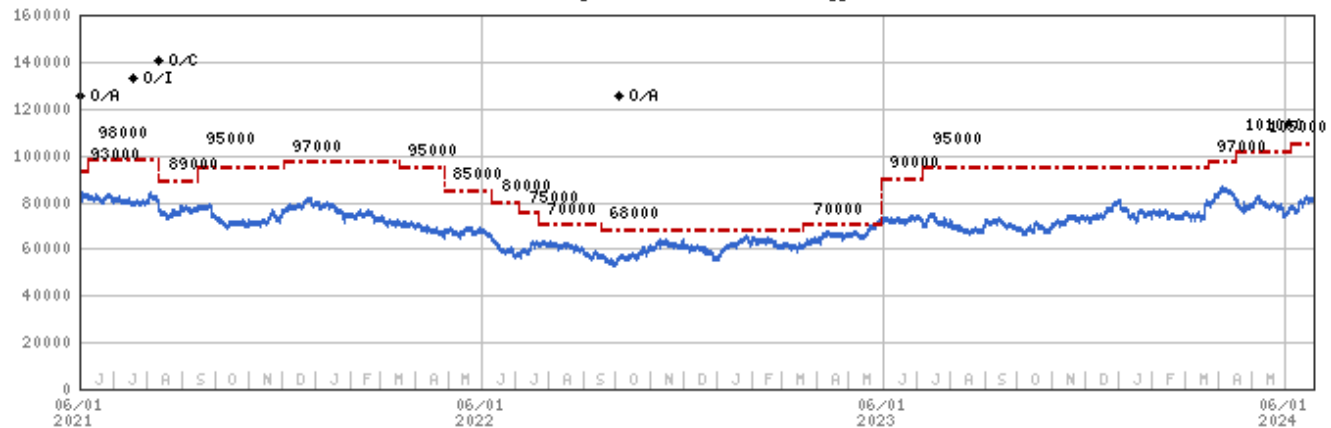
Price Target History: 4/25/19 : 140000; 7/26/19 : 160000; 8/6/19 : 170000; 10/31/19 : 190000; 11/17/19 : NA; 2/13/20 : NA; 3/17/20 : NA; 8/3/20 : NA; 11/23/20 : 340000; 1/25/21 : 420000; 1/28/21 : 440000; 3/23/21 : 490000; 4/29/21 : 460000; 7/1/21 : 500000; 9/28/21 : 480000; 1/10/22 : 410000; 1/27/22 : 370000; 4/22/22 : 320000; 7/18/22 : 260000; 8/8/22 : 230000; 10/14/22 : 160000; 11/7/22 : 150000; 8/7/23 : 180000; 5/7/24 : 200000

Source: Morgan Stanley Research Date Format : MM/DD/YY Price Target --- No Price Target Assigned (NA)  
 Stock Price (Not Covered by Current Analyst) --- Stock Price (Covered by Current Analyst) ■  
 Stock and Industry Ratings (abbreviations below) appear as ♦ Stock Rating/Industry View  
 Stock Ratings: Overweight (O) Equal-weight (E) Underweight (U) Not-Rated (NR) No Rating Available (NA)  
 Industry View: Attractive (A) In-line (I) Cautious (C) No Rating (NR)

Effective January 13, 2014, the stocks covered by Morgan Stanley Asia Pacific will be rated relative to the analyst's industry (or industry team's) coverage.

Effective January 13, 2014, the industry view benchmarks for Morgan Stanley Asia Pacific are as follows: relevant MSCI country index or MSCI sub-regional index or MSCI AC Asia Pacific ex Japan Index.

Samsung Electronics (005930.KS) - As of 06/26/24 GMT in KRW  
 Industry : S. Korea Technology



Stock Rating History: 6/1/19 : E/C; 7/30/19 : E/I; 11/18/19 : O/A; 7/19/21 : O/I; 8/12/21 : O/C; 10/4/22 : O/A

Price Target History: 1/15/19 : 40000; 7/30/19 : 53000; 8/16/19 : 48000; 9/10/19 : 50000; 11/18/19 : 60000; 1/14/20 : 72000; 2/26/20 : 75000; 3/19/20 : 68000; 4/29/20 : 65000; 7/12/20 : 70000; 9/11/20 : 73000; 11/27/20 : 88000; 1/12/21 : 110000; 2/25/21 : 115000; 5/18/21 : 93000; 6/8/21 : 98000; 8/12/21 : 89000; 9/15/21 : 95000; 12/3/21 : 97000; 3/18/22 : 95000; 4/28/22 : 85000; 6/10/22 : 80000; 7/5/22 : 75000; 7/22/22 : 70000; 9/17/22 : 68000; 3/21/23 : 70000; 5/30/23 : 90000; 7/7/23 : 95000; 3/22/24 : 97000; 4/16/24 : 101000; 6/6/24 : 105000

Source: Morgan Stanley Research Date Format : MM/DD/YY Price Target --- No Price Target Assigned (NA)  
 Stock Price (Not Covered by Current Analyst) --- Stock Price (Covered by Current Analyst) ■  
 Stock and Industry Ratings (abbreviations below) appear as ♦ Stock Rating/Industry View  
 Stock Ratings: Overweight (O) Equal-weight (E) Underweight (U) Not-Rated (NR) No Rating Available (NA)  
 Industry View: Attractive (A) In-line (I) Cautious (C) No Rating (NR)

Effective January 13, 2014, the stocks covered by Morgan Stanley Asia Pacific will be rated relative to the analyst's industry (or industry team's) coverage.

Effective January 13, 2014, the industry view benchmarks for Morgan Stanley Asia Pacific are as follows: relevant MSCI country index or MSCI sub-regional index or MSCI AC Asia Pacific ex Japan Index.

Samsung SDI (006400.KS) - As of 06/26/24 GMT in KRW  
Industry : S. Korea Technology



Stock Rating History: 6/1/19 : 0/C; 7/30/19 : 0/I; 11/18/19 : 0/A; 8/14/20 : U/A; 1/22/21 : E/A; 5/30/21 : U/A; 7/19/21 : U/I; 8/12/21 : U/C; 10/26/21 : E/C; 10/4/22 : E/A  
 Price Target History: 11/21/18 : 260000; 8/16/19 : 300000; 10/18/19 : 250000; 1/17/20 : 300000; 3/19/20 : 280000; 5/4/20 : 300000; 6/10/20 : 420000; 8/14/20 : 400000; 12/30/20 : 500000; 1/22/21 : 710000; 1/28/21 : 690000; 4/14/21 : 570000; 5/30/21 : 550000; 7/27/21 : 600000; 10/26/21 : 720000; 3/18/22 : 550000; 7/11/22 : 560000; 10/26/22 : 620000; 11/29/22 : 650000; 3/10/23 : 740000; 10/6/23 : 670000; 11/2/23 : 610000; 12/21/23 : 570000

Source: Morgan Stanley Research Date Format : MM/DD/YY Price Target -- No Price Target Assigned (NA)  
 Stock Price (Not Covered by Current Analyst) — Stock Price (Covered by Current Analyst) —  
 Stock and Industry Ratings (abbreviations below) appear as ♦ Stock Rating/Industry View  
 Stock Ratings: Overweight (O) Equal-weight (E) Underweight (U) Not-Rated (NR) No Rating Available (NA)  
 Industry View: Attractive (A) In-line (I) Cautious (C) No Rating (NR)

Effective January 13, 2014, the stocks covered by Morgan Stanley Asia Pacific will be rated relative to the analyst's industry (or industry team's) coverage.

Effective January 13, 2014, the industry view benchmarks for Morgan Stanley Asia Pacific are as follows: relevant MSCI country index or MSCI sub-regional index or MSCI AC Asia Pacific ex Japan Index.

SK hynix (000660.KS) - As of 06/26/24 GMT in KRW  
Industry : S. Korea Technology



Stock Rating History: 6/1/19 : U/C; 7/30/19 : E/I; 11/18/19 : 0/A; 7/19/21 : 0/I; 8/12/21 : U/C; 12/3/21 : E/C; 2/11/22 : 0/C; 7/22/22 : E/C; 10/4/22 : 0/A

Price Target History: 4/25/19 : 70000; 6/4/19 : 61000; 7/25/19 : 70000; 7/30/19 : 85000; 8/16/19 : 80000; 9/10/19 : 81000; 11/18/19 : 95000; 1/14/20 : 115000; 2/26/20 : 120000; 3/19/20 : 110000; 8/21/20 : 93000; 10/23/20 : 100000; 12/2/20 : 160000; 1/12/21 : 170000; 2/25/21 : 174000; 5/18/21 : 146000; 6/8/21 : 156000; 8/12/21 : 80000; 9/15/21 : 88000; 12/3/21 : 110000; 12/23/21 : 125000; 1/24/22 : 130000; 1/28/22 : 136000; 2/11/22 : 155000; 3/18/22 : 150000; 4/27/22 : 130000; 6/10/22 : 120000; 7/5/22 : 110000; 7/22/22 : 105000; 10/4/22 : 130000; 12/7/22 : 120000; 3/21/23 : 110000; 5/30/23 : 140000; 7/7/23 : 170000; 9/21/23 : 210000; 3/22/24 : 230000; 4/16/24 : 270000; 6/6/24 : 300000

Source: Morgan Stanley Research Date Format : MM/DD/YY Price Target -- No Price Target Assigned (NA)  
 Stock Price (Not Covered by Current Analyst) — Stock Price (Covered by Current Analyst) —  
 Stock and Industry Ratings (abbreviations below) appear as ♦ Stock Rating/Industry View  
 Stock Ratings: Overweight (O) Equal-weight (E) Underweight (U) Not-Rated (NR) No Rating Available (NA)  
 Industry View: Attractive (A) In-line (I) Cautious (C) No Rating (NR)

Effective January 13, 2014, the stocks covered by Morgan Stanley Asia Pacific will be rated relative to the analyst's industry (or industry team's) coverage.

Effective January 13, 2014, the industry view benchmarks for Morgan Stanley Asia Pacific are as follows: relevant MSCI country index or MSCI sub-regional index or MSCI AC Asia Pacific ex Japan Index.

SK Innovation Co Ltd (096770.KS) - As of 06/26/24 GMT in KRW  
Industry : S. Korea Energy & Materials



Stock Rating History: 6/1/19 : NA/A; 8/20/19 : E/A; 8/14/20 : U/A; 10/30/20 : E/A; 4/12/21 : O/A; 5/13/21 : E/A; 8/5/21 : O/A; 11/29/21 : E/A; 3/10/23 : O/A; 2/7/24 : E/A

Price Target History: 8/20/19 : 167271.84; 10/3/19 : 177111.36; 1/7/20 : 157432.31; 2/3/20 : 137753.28; 3/18/20 : 88555.68; 5/6/20 : 108234.72; 7/8/20 : 118074.24; 7/29/20 : 127913.76; 8/14/20 : 147592.8; 10/12/20 : 137753.28; 1/11/21 : 255827.52; 4/12/21 : 324704.16; 5/13/21 : 285346.06; 7/8/21 : 295185.59; 8/5/21 : 305025.13; 9/30/21 : 334543.69; 11/29/21 : 226308.95; 4/4/22 : 236148.48; 7/6/22 : 196790.39; 8/24/22 : 226308.95; 11/3/22 : 196790.39; 1/3/23 : 157432.31; 2/7/23 : 177111.36; 3/10/23 : 236148.48; 4/6/23 : 226308.95; 7/6/23 : 206629.92; 8/25/23 : 220000; 10/4/23 : 200000; 11/3/23 : 180000; 1/5/24 : 160000; 2/7/24 : 130000

Source: Morgan Stanley Research Date Format : MM/DD/YY Price Target -- No Price Target Assigned (NA)  
Stock Price (Not Covered by Current Analyst) — Stock Price (Covered by Current Analyst) ■  
Stock and Industry Ratings (abbreviations below) appear as ♦ Stock Rating/Industry View  
Stock Ratings: Overweight (O) Equal-weight (E) Underweight (U) Not-Rated (NR) No Rating Available (NA)  
Industry View: Attractive (A) In-line (I) Cautious (C) No Rating (NR)

Effective January 13, 2014, the stocks covered by Morgan Stanley Asia Pacific will be rated relative to the analyst's industry (or industry team's) coverage.

Effective January 13, 2014, the industry view benchmarks for Morgan Stanley Asia Pacific are as follows: relevant MSCI country index or MSCI sub-regional index or MSCI AC Asia Pacific ex Japan Index.

## Important Disclosures for Morgan Stanley Smith Barney LLC & E\*TRADE Securities LLC Customers

Important disclosures regarding the relationship between the companies that are the subject of Morgan Stanley Research and Morgan Stanley Smith Barney LLC or Morgan Stanley or any of their affiliates, are available on the Morgan Stanley Wealth Management disclosure website at [www.morganstanley.com/online/researchdisclosures](http://www.morganstanley.com/online/researchdisclosures). For Morgan Stanley specific disclosures, you may refer to [www.morganstanley.com/researchdisclosures](http://www.morganstanley.com/researchdisclosures).

Each Morgan Stanley research report is reviewed and approved on behalf of Morgan Stanley Smith Barney LLC and E\*TRADE Securities LLC. This review and approval is conducted by the same person who reviews the research report on behalf of Morgan Stanley. This could create a conflict of interest.

## Other Important Disclosures

Morgan Stanley & Co. International PLC and its affiliates have a significant financial interest in the debt securities of Amazon.com Inc, Baker Hughes Co, BMW, DHL Group, Ford Motor Company, General Motors Company, Halliburton Co, Infineon Technologies AG, JD.com, Inc., McDonald's Corporation, Mercedes-Benz Group AG, NTN, NVIDIA Corp., Obayashi, ON Semiconductor Corp., Qualcomm Inc., Shimizu, Siemens, SK hynix, Stellantis, STMicroelectronics NV, Taisei, Tesla Inc, Toyota Motor, TSMC.

A member of Research who had or could have had access to the research prior to completion owns securities (or related derivatives) in the Ford Motor Company, NVIDIA Corp.. This person is not a research analyst or a member of research analyst's household.

Morgan Stanley Research policy is to update research reports as and when the Research Analyst and Research Management deem appropriate, based on developments with the issuer, the sector, or the market that may have a material impact on the research views or opinions stated therein. In addition, certain Research publications are intended to be updated on a regular periodic basis (weekly/monthly/quarterly/annual) and will ordinarily be updated with that frequency, unless the Research Analyst and Research Management determine that a different publication schedule is appropriate based on current conditions.

Morgan Stanley is not acting as a municipal advisor and the opinions or views contained herein are not intended to be, and do not constitute, advice within the meaning of Section 975 of the Dodd-Frank Wall Street Reform and Consumer Protection Act.

Morgan Stanley produces an equity research product called a "Tactical Idea." Views contained in a "Tactical Idea" on a particular stock may be contrary to the recommendations or views expressed in research on the same stock. This may be the result of differing time horizons, methodologies, market events, or other factors. For all research available on a particular stock, please contact your sales representative or go to Matrix at <http://www.morganstanley.com/matrix>.

Morgan Stanley Research is provided to our clients through our proprietary research portal on Matrix and also distributed electronically by Morgan Stanley to clients. Certain, but not all, Morgan Stanley Research products are also made available to clients through third-party vendors or redistributed to clients through alternate electronic means as a convenience. For access to all available Morgan Stanley Research, please contact your sales representative or go to Matrix at <http://www.morganstanley.com/matrix>.

Any access and/or use of Morgan Stanley Research is subject to Morgan Stanley's Terms of Use (<http://www.morganstanley.com/terms.html>). By accessing and/or using Morgan Stanley Research, you are indicating that you have read and agree to be bound by our Terms of Use (<http://www.morganstanley.com/terms.html>). In addition you consent to Morgan Stanley processing



your personal data and using cookies in accordance with our Privacy Policy and our Global Cookies Policy ([http://www.morganstanley.com/privacy\\_pledge.html](http://www.morganstanley.com/privacy_pledge.html)), including for the purposes of setting your preferences and to collect readership data so that we can deliver better and more personalized service and products to you. To find out more information about how Morgan Stanley processes personal data, how we use cookies and how to reject cookies see our Privacy Policy and our Global Cookies Policy ([http://www.morganstanley.com/privacy\\_pledge.html](http://www.morganstanley.com/privacy_pledge.html)).

If you do not agree to our Terms of Use and/or if you do not wish to provide your consent to Morgan Stanley processing your personal data or using cookies please do not access our research. Morgan Stanley Research does not provide individually tailored investment advice. Morgan Stanley Research has been prepared without regard to the circumstances and objectives of those who receive it. Morgan Stanley recommends that investors independently evaluate particular investments and strategies, and encourages investors to seek the advice of a financial adviser. The appropriateness of an investment or strategy will depend on an investor's circumstances and objectives. The securities, instruments, or strategies discussed in Morgan Stanley Research may not be suitable for all investors, and certain investors may not be eligible to purchase or participate in some or all of them. Morgan Stanley Research is not an offer to buy or sell or the solicitation of an offer to buy or sell any security/instrument or to participate in any particular trading strategy. The value of and income from your investments may vary because of changes in interest rates, foreign exchange rates, default rates, prepayment rates, securities/instruments prices, market indexes, operational or financial conditions of companies or other factors. There may be time limitations on the exercise of options or other rights in securities/instruments transactions. Past performance is not necessarily a guide to future performance. Estimates of future performance are based on assumptions that may not be realized. If provided, and unless otherwise stated, the closing price on the cover page is that of the primary exchange for the subject company's securities/instruments.

The fixed income research analysts, strategists or economists principally responsible for the preparation of Morgan Stanley Research have received compensation based upon various factors, including quality, accuracy and value of research, firm profitability or revenues (which include fixed income trading and capital markets profitability or revenues), client feedback and competitive factors. Fixed Income Research analysts', strategists' or economists' compensation is not linked to investment banking or capital markets transactions performed by Morgan Stanley or the profitability or revenues of particular trading desks.

The "Important Regulatory Disclosures on Subject Companies" section in Morgan Stanley Research lists all companies mentioned where Morgan Stanley owns 1% or more of a class of common equity securities of the companies. For all other companies mentioned in Morgan Stanley Research, Morgan Stanley may have an investment of less than 1% in securities/instruments or derivatives of securities/instruments of companies and may trade them in ways different from those discussed in Morgan Stanley Research. Employees of Morgan Stanley not involved in the preparation of Morgan Stanley Research may have investments in securities/instruments or derivatives of securities/instruments of companies mentioned and may trade them in ways different from those discussed in Morgan Stanley Research. Derivatives may be issued by Morgan Stanley or associated persons.

With the exception of information regarding Morgan Stanley, Morgan Stanley Research is based on public information. Morgan Stanley makes every effort to use reliable, comprehensive information, but we make no representation that it is accurate or complete. We have no obligation to tell you when opinions or information in Morgan Stanley Research change apart from when we intend to discontinue equity research coverage of a subject company. Facts and views presented in Morgan Stanley Research have not been reviewed by, and may not reflect information known to, professionals in other Morgan Stanley business areas, including investment banking personnel.

Morgan Stanley Research personnel may participate in company events such as site visits and are generally prohibited from accepting payment by the company of associated expenses unless pre-approved by authorized members of Research management.

Morgan Stanley may make investment decisions that are inconsistent with the recommendations or views in this report.

To our readers based in Taiwan or trading in Taiwan securities/instruments: Information on securities/instruments that trade in Taiwan is distributed by Morgan Stanley Taiwan Limited ("MSTL"). Such information is for your reference only. The reader should independently evaluate the investment risks and is solely responsible for their investment decisions. Morgan Stanley Research may not be distributed to the public media or quoted or used by the public media without the express written consent of Morgan Stanley. Any non-customer reader within the scope of Article 7-1 of the Taiwan Stock Exchange Recommendation Regulations accessing and/or receiving Morgan Stanley Research is not permitted to provide Morgan Stanley Research to any third party (including but not limited to related parties, affiliated companies and any other third parties) or engage in any activities regarding Morgan Stanley Research which may create or give the appearance of creating a conflict of interest. Information on securities/instruments that do not trade in Taiwan is for informational purposes only and is not to be construed as a recommendation or a solicitation to trade in such securities/instruments. MSTL may not execute transactions for clients in these securities/instruments.

Certain information in Morgan Stanley Research was sourced by employees of the Shanghai Representative Office of Morgan Stanley Asia Limited for the use of Morgan Stanley Asia Limited. Morgan Stanley is not incorporated under PRC law and the research in relation to this report is conducted outside the PRC. Morgan Stanley Research does not constitute an offer to sell or the solicitation of an offer to buy any securities in the PRC. PRC investors shall have the relevant qualifications to invest in such securities and shall be responsible for obtaining all relevant approvals, licenses, verifications and/or registrations from the relevant governmental authorities themselves. Neither this report nor any part of it is intended as, or shall constitute, provision of any consultancy or advisory service of securities investment as defined under PRC law. Such information is provided for your reference only.

Morgan Stanley Research is disseminated in Brazil by Morgan Stanley C.T.V.M. S.A. located at Av. Brigadeiro Faria Lima, 3600, 6th floor, São Paulo - SP, Brazil; and is regulated by the Comissão de Valores Mobiliários; in Mexico by Morgan Stanley México, Casa de Bolsa, S.A. de C.V. which is regulated by Comisión Nacional Bancaria y de Valores. Paseo de los Tamarindos 90, Torre 1, Col. Bosques de las Lomas Floor 29, 05120 Mexico City; in Japan by Morgan Stanley MUFG Securities Co., Ltd. and, for Commodities related research reports only, Morgan Stanley Capital Group Japan Co., Ltd; in Hong Kong by Morgan Stanley Asia Limited (which accepts responsibility for its contents) and by Morgan Stanley Bank Asia Limited; in Singapore by Morgan Stanley Asia (Singapore) Pte. (Registration number 199206298Z) and/or Morgan Stanley Asia (Singapore) Securities Pte Ltd (Registration number 200008434H), regulated by the Monetary Authority of Singapore (which accepts legal responsibility for its contents and should be contacted with respect to any matters arising from, or in connection with, Morgan Stanley Research) and by Morgan Stanley Bank Asia Limited, Singapore Branch (Registration number T14FC0118); in Australia to "wholesale clients" within the meaning of the Australian Corporations Act by Morgan Stanley Australia Limited A.B.N. 67 003 734 576, holder of Australian financial services license No. 233742, which accepts responsibility for its contents; in Australia to "wholesale clients" and "retail clients" within the meaning of the Australian Corporations Act by Morgan Stanley Wealth Management Australia Pty Ltd (A.B.N. 19 009 145 555, holder of Australian financial services license No. 240813, which accepts responsibility for its contents; in Korea by Morgan Stanley & Co International plc, Seoul Branch; in India by Morgan Stanley India Company Private Limited having Corporate Identification No (CIN) U22990MH1998PTC115305, regulated by the Securities and Exchange Board of India ("SEBI") and holder of licenses as a Research Analyst (SEBI Registration No. INH00001105); Stock Broker (SEBI Stock Broker Registration No. INZ000244438), Merchant Banker (SEBI Registration No. INM000011203), and depository participant with National Securities Depository Limited (SEBI Registration No. IN-DP-NSDL-567-2021) having registered office at 18th Floor, Tower 2, One World Center, Plot- 841, Jupiter Textile Mill Compound, Senapati Bapat Marg, Lower Parel, Mumbai 400013, India Telephone no. +91-22-61181000; Compliance Officer Details: Mr. Tejarshi Hardas, Tel. No.: +91-22-61181000 or Email: tejarshi.hardas@morganstanley.com; Grievance officer details: Mr. Tejarshi Hardas, Tel. No.: +91-22-61181000 or Email: msic-compliance@morganstanley.com; in Canada by Morgan Stanley Canada Limited; in Germany and the European Economic Area where required by Morgan Stanley Europe S.E., authorised and regulated by Bundesanstalt fuer Finanzdienstleistungsaufsicht (BaFin) under the reference number 149169; in the US by Morgan Stanley & Co. LLC, which accepts responsibility for its contents. Morgan Stanley & Co. International plc, authorized by the Prudential Regulation Authority and regulated by the Financial Conduct Authority and the Prudential Regulation Authority, disseminates in the UK research that it has prepared, and research which has been prepared by any of its affiliates, only to persons who (i) are investment professionals falling within Article 19(5) of the Financial Services and Markets Act 2000 (Financial Promotion) Order 2005 (as amended, the "Order"); (ii) are persons who are high net worth entities falling within Article 49(2)(a) to (d) of the Order; or (iii) are persons to whom an invitation or inducement to engage in investment

activity (within the meaning of section 21 of the Financial Services and Markets Act 2000, as amended) may otherwise lawfully be communicated or caused to be communicated. RMB Morgan Stanley Proprietary Limited is a member of the JSE Limited and A2X (Pty) Ltd. RMB Morgan Stanley Proprietary Limited is a joint venture owned equally by Morgan Stanley International Holdings Inc. and RMB Investment Advisory (Proprietary) Limited, which is wholly owned by FirstRand Limited. The information in Morgan Stanley Research is being disseminated by Morgan Stanley Saudi Arabia, regulated by the Capital Market Authority in the Kingdom of Saudi Arabia, and is directed at Sophisticated investors only.

Morgan Stanley Hong Kong Securities Limited is the liquidity provider/market maker for securities of BYD Company Limited, China State Construction Engineering, Haidilao International Holding Ltd, JD.com, Inc., XPeng Inc. listed on the Stock Exchange of Hong Kong Limited. An updated list can be found on HKEx website: <http://www.hkex.com.hk>.

The information in Morgan Stanley Research is being communicated by Morgan Stanley & Co. International plc (DIFC Branch), regulated by the Dubai Financial Services Authority (the DFSA), and is directed at Professional Clients only, as defined by the DFSA. The financial products or financial services to which this research relates will only be made available to a customer who we are satisfied meets the regulatory criteria to be a Professional Client. A distribution of the different MS Research ratings or recommendations, in percentage terms for investments in each sector covered, is available upon request from your sales representative.

The information in Morgan Stanley Research is being communicated by Morgan Stanley & Co. International plc (QFC Branch), regulated by the Qatar Financial Centre Regulatory Authority (the QFCRA), and is directed at business customers and market counterparties only and is not intended for Retail Customers as defined by the QFCRA.

As required by the Capital Markets Board of Turkey, investment information, comments and recommendations stated here, are not within the scope of investment advisory activity. Investment advisory service is provided exclusively to persons based on their risk and income preferences by the authorized firms. Comments and recommendations stated here are general in nature. These opinions may not fit to your financial status, risk and return preferences. For this reason, to make an investment decision by relying solely to this information stated here may not bring about outcomes that fit your expectations.

The following companies do business in countries which are generally subject to comprehensive sanctions programs administered or enforced by the U.S. Department of the Treasury's Office of Foreign Assets Control ("OFAC") and by other countries and multi-national bodies: Samsung Electronics.

The trademarks and service marks contained in Morgan Stanley Research are the property of their respective owners. Third-party data providers make no warranties or representations relating to the accuracy, completeness, or timeliness of the data they provide and shall not have liability for any damages relating to such data. The Global Industry Classification Standard (GICS) was developed by and is the exclusive property of MSCI and S&P.

Morgan Stanley Research, or any portion thereof may not be reprinted, sold or redistributed without the written consent of Morgan Stanley.

Indicators and trackers referenced in Morgan Stanley Research may not be used as, or treated as, a benchmark under Regulation EU 2016/1011, or any other similar framework.

The issuers and/or fixed income products recommended or discussed in certain fixed income research reports may not be continuously followed. Accordingly, investors should regard those fixed income research reports as providing stand-alone analysis and should not expect continuing analysis or additional reports relating to such issuers and/or individual fixed income products. Morgan Stanley may hold, from time to time, material financial and commercial interests regarding the company subject to the Research report.

Registration granted by SEBI and certification from the National Institute of Securities Markets (NISM) in no way guarantee performance of the intermediary or provide any assurance of returns to investors. Investment in securities market are subject to market risks. Read all the related documents carefully before investing.

The following authors are Fixed Income Research Analysts/Strategists and are not opining on or expressing recommendations on equity securities: Ariana Salvatore.

The following authors are neither Equity Research Analysts/Strategists nor Fixed Income Research Analysts/Strategists and are not opining on or expressing recommendations on equity or fixed income securities: Sarah A Wolfe; Seth B Carpenter; Arunima Sinha.

# Morgan Stanley

© Morgan Stanley 2024

## **The Americas**

1585 Broadway  
New York, NY 10036-8293  
United States  
Tel: **+1 (1) 212 761 4000**

## **Europe**

20 Bank Street, Canary Wharf  
London E14 4AD  
United Kingdom  
Tel: **+44 (0) 20 7 425 8000**

## **Japan**

1-9-7 Otemachi, Chiyoda-ku  
Tokyo 100-8104  
Japan  
Tel: **+81 (0) 3 6836 5000**

## **Asia/Pacific**

1 Austin Road West  
Kowloon  
Hong Kong  
Tel: **+852 2848 5200**